



Engineering Capabilities

Rayson | **Industrial Controls**

a relevant.company

About Rawson/Industrial Controls

About Rawson/Industrial Controls

Created by joining two industry-leading companies in 2019, Rawson/Industrial Controls offers more than 100 years of combined experience serving customers in the oil and gas, chemical, refining, pharmaceutical, pulp and paper, food and beverage, water and wastewater, and power generation industries. With a team of in-house engineers, along with instrumentation and valve customization services, Rawson/Industrial Controls designs and customizes product solutions to help customers solve complex problems. The company currently has partnerships in 31 states across the Gulf Coast, Mid-Atlantic, Midwest, Northeast, Southeast, and Southwest regions of the U.S.

Markets Served



MACHINE/EQUIPMENT CONTROL



OIL & GAS/CHEMICAL



POWER GENERATION/DISTRIBUTION



PROCESS/MANUFACTURING



TRANSPORTATION & INFRASTRUCTURE



WATER/WASTEWATER

Services We Offer

- On-Site and Factory Classroom Training
- Applications Engineering
- Software Asset Management
- Control System Modernization & Audits
- Extended Warranty
- Extensive Evaluation Unit Demo Inventory
- Proof of Concept Systems
- Software Maintenance Contract Management
- Integrator & OEM Software Toolkits

Engineering Services Include

- Control Network Support
- DCS and PLC Programming
- Engineering CAD Drawings
- Prototype Development
- HMI/SCADA Programming
- System Tuning and Updates
- VFD Start-Up
- Customized Training

Valves, Instrumentation & Controls Services

Advice on Product Selection

Our customers rely on us to help them size and select products for their applications. Our experienced sales organization has wide product and application know-how.

Design & Co-Engineered Solutions

Our tailor-made solutions help customers solve their difficult process control problems. We have in-house engineering and design capabilities at multiple locations based in Texas, New Jersey, and Wisconsin.

Valve Automation

We offer the complete package (control valve, actuator, and instruments) that is assembled, tested, and ready for installation.

- Standard and custom valve configurations
- Complete documentation of engineering drawings for assemblies

Steam Trap Surveys

Rawson and Energy Management & Technology (EM&T) provide the most accurate data and the highest quality products needed to improve the steam quality, equipment reliability, and steam system safety at your site.

Thermal Processing & Heating Controls

- Highly accurate temperature, humidity, and airflow control reduces energy costs and product waste, while producing a superior product.
- Automated recipe archival and execution maintains product consistency, simplifies changes, and reduces operator intervention.

- Real-time centralized monitoring and control optimizes process supervision and coordination activities.
- Web-enabled monitoring and automated paging capabilities provide remote access and alarm notifications.
- Automated alarm processing speeds problem recognition and reduces downtime.
- Historical data provides batch histories for customer and regulatory compliance documentation.
- Embedded control philosophies maintain product consistency and improve access safety.

Instrument Service

Improved delivery times, more efficient inventory management, and less inventory shrinkage through:

- Product modifications, such as calibration and liquid filling of gauges
- Bag and tag
- Rental tool program
- Minor sub-assemblies

Automation & SCADA Programming

Our customer gets a complete solution that is designed, assembled, tested, ready for installation, and customizable from a remote location.

- Standard and custom configurations
- Specified solutions with right computer hardware, software, controllers, and all interfaces

Our Automation Vendor Partners



Automation Solutions Built For Industry 4.0 And Beyond. From creating the first remote I/O with Genius, to our modern-day outcome-optimizing controllers that revolutionized the PLC, Emerson continues to surpass conventional standards to help customers maximize the power of the Industrial Internet. Emerson's next generation industrial automation and control solutions optimize industrial processes safely, securely and reliably to give you peace of mind while helping realize higher performance of operations in any environment.

	Total power quality solutions keep production lines moving while keeping people, equipment and information safe.		Multi-radio edge compute platform with gateways, edge data analytics, and applications.
	Industrial networking, secure remote access, cellular RTUs, IIOT gateways and routers, protocol and media conversion, HMI and edge controls.		Industrial networking, secure remote access, cellular RTUs, IIOT gateways and routers, protocol and media conversion, HMI and edge controls.
	All-in-one controllers, consisting of programmable HMI, I/O, software, and peripherals for the industrial, process control, and building automation markets.		Rugged laptops and tablets for harsh industrial and hazardous locations. Wide range of computing technology from low power edge devices to high performance plantwide servers.
	The first reporting software developed for industry to fully embrace the latest Microsoft Office technology. More than just reports. It provides a scheduler, data logger, manual data entry and powerful analytics.		Secure remote access and operations doesn't have to be complicated, expensive, or time-consuming.
	Provides connectivity solutions that link dissimilar automation products. Products include PLC Remote Access, Communication Gateways and Industrial Wireless connectivity.		Honeywell Process Solutions (HPS) - Distributed Control Systems (DCS), Modular Process Controller, Remote Terminal Units (RTU), Wireless I/O and Sensor Transmitters.
	The recognized industry standard for alarm notification and management.		Industrial connectivity solutions to help businesses connect diverse automation devices and software applications.
	Industrial automation products rich in features and designed for easy operation and reduced engineering time. Market-leading control algorithms, recording and data management		For over half a century, ABB has developed, manufactured, supplied and installed analytical instruments for the laboratory, process, environmental, steam and power industries.



Industry Solutions

Machine/Equipment Control

- Assembly
- Inspection Machinery
- Packaging Equipment Control
- Labelling
- Plant Floor Dashboarding
- Inspection
- Predictive Maintenance



Oil & Gas/Chemical

- Wireless Tank Monitoring
- Distributed Control Systems (DCS)
- Harsh/Hazardous Area Systems
- SIL Safety Systems
- Vibration Monitoring
- Emissions Compliance & Reporting



Power Generation/Distribution

- Advanced Alarm Annunciation
- DNP3/IEC 61850 Integration
- Pothead Pressure Monitoring
- Balance of Plant Controls
- Safety Shutdown



Industry Solutions

Process/Manufacturing

- Heat Treating
- Temperature Control
- Batch Management
- Process Visualization
- Historian & Analytics
- Regulatory Compliance

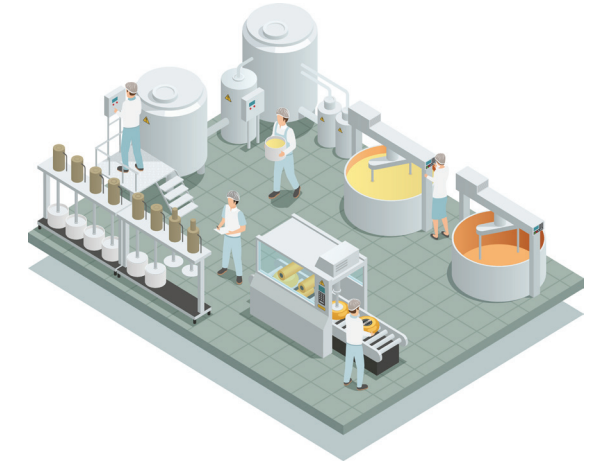

Transportation & Infrastructure

- Tunnel Ventilation
- Airport & Bridge Lighting Control
- Sequence of Events Recording
- Critical Power Monitoring
- High Availability Power
- Building Automation



Water/Wastewater

- Redundant Controller Architecture
- Remote Terminal Unit (RTU)
- Cellular Connectivity
- Plant wide HMI/SCADA
- Protocol Conversion & Networking Infrastructure
- Emissions Compliance & Reporting

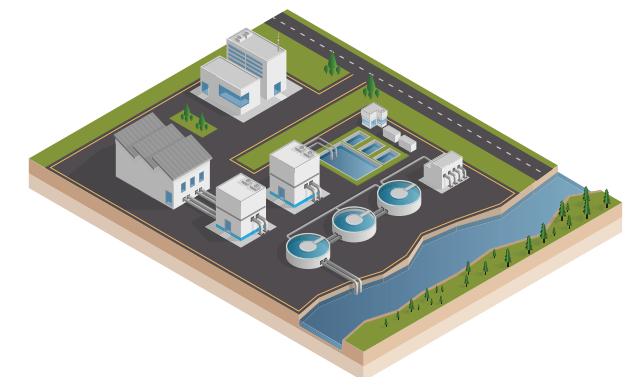

Case Study

Wireless Tank Farm Monitoring

Company Profile

This customer is a leading specialty chemicals company with 60 production sites worldwide. They specialize in the development, manufacturing, and marketing of chemical intermediates, additives, specialty chemicals, and plastics.

Challenge

An industrial lubricants manufacturer maintains over 50 tanks of finished material. The operator selects which tanks' product is to be transferred to a given truck based on inventory in the many tanks on premises. Without a live system giving the operator tank levels, the operator needs to estimate the actual inventory being held in the tanks or deploy plant personnel to climb the tank to gauge the level using a long, measured rod. During winter, safety was a concern for personnel physically climbing the tanks to gauge them. The tank farm lacked signal and power wiring for instrumentation.

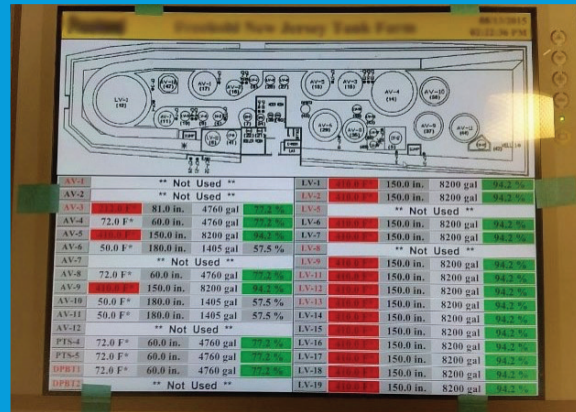

Solution

Rawson/Industrial Controls provided a wireless pressure monitoring system to measure 50 individual tank levels through a customer-installed bubbler system, using Honeywell's ISA100 standard wireless system. The 50 wireless differential pressure transmitters communicate throughout the tank farm to two field access points, which communicate to a gateway serving the information to the customer's computer using Modbus TCP or OPC protocols.

Rawson/Industrial Controls provided GE Digital's Cimplicity HMI/SCADA software to display real-time tank levels for the operator so that there would always be visibility of where inventory was being held, and technicians would no longer need to climb the tanks to take measurements.

At a cost of \$90,000, this project was 50% less costly than running a wired infrastructure. The wireless system also provides an easier expansion path since new wiring was not needed when the customer chose to add 10 more devices to the system.

Results

With a functional wireless instrumentation network in place, the plant has added other wireless instruments related to safety, such as remote indication of safety shower use and sump overflow level detection.

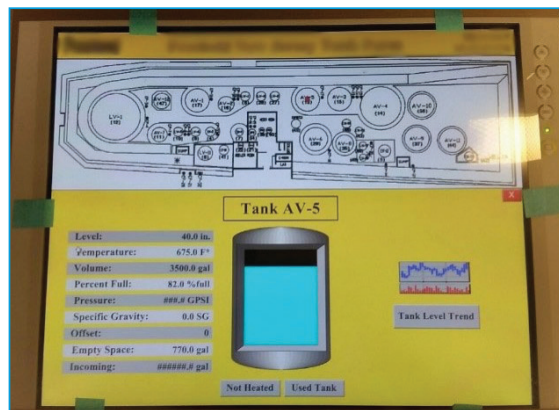

Case Study

Campus Energy

Company Profile

This company is one of the largest commercial and industrial real estate sites in NYC. Various commercial tenants rent space from the management company and are billed for utility usage. The 300-acre site is home to over 330 industrial tenants employing more than 6,400 people, up from 3,600 in 2001.

Challenge

An industrial lubricants manufacturer maintains over 50 tanks of finished material. The operator selects which tanks' product is to be transferred to a given truck based on inventory in the many tanks on premises. Without a live system giving the operator tank levels, the operator needs to estimate the actual inventory being held in the tanks or deploy plant personnel to climb the tank to gauge the level using a long, measured rod. During winter, safety was a concern for personnel physically climbing the tanks to gauge them. The tank farm lacked signal and power wiring for instrumentation.

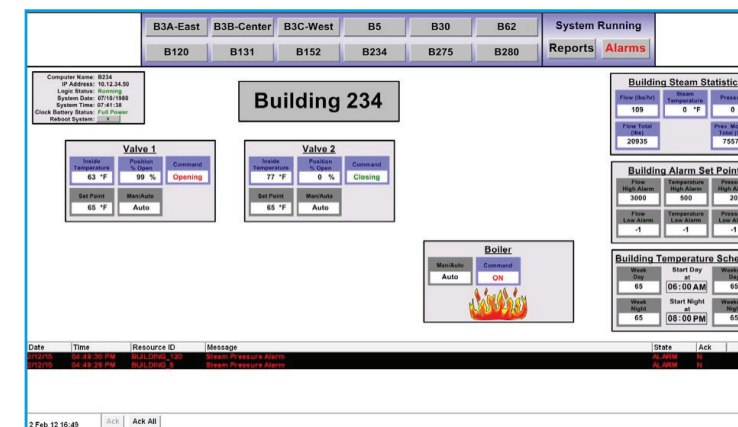

Solution

Rawson/Industrial Controls installed a complete system for remote control and monitoring of the existing steam system. The solution consisted of automated valves and actuators, which are controlled by an RTU panel at each building or floor, and a site-wide SCADA system.

Each RTU has a local HMI and PLC which collects and controls steam aspects, such as valve position, building temperatures, steam temperatures, outside temperature, steam pressure, steam flow, and flow totals. The SCADA hosts all this data for remote monitoring and control via PC or mobile device. This allows for advanced functionality, such as scheduled set point control, total steam usage calculation, automatic report generation, and SMS/email alarm notification.

Additional benefits derived from this solution:

- Ability to locate and indicate steam leaks.
- Immediate notification of high steam pressure or component failures, reducing serious safety hazards.
- Instant system control within seconds, as opposed to the hours it would take to manually apply control, including a full system emergency shutdown.
- More complete and accurate system data, which can be used to create better usage reports and accurate billing.

Results

The total investment for this project was \$200,000 and was delivered in 10 weeks. The cost of constant loss of steam, excessive heating, and additional labor to maintain and operate the existing system was over \$75,000 per year, creating a 2.6 year ROI.

Case Study

Wireless Data Access

Company Profile

This customer is one of the world's largest energy delivery systems as a provider of electric, gas, and steam.

Challenge

A power utility needed to install new aquatic life filters on their incoming water feed from the local river bordering the facility. Code changes necessitated the installation of new filters to protect the environment and company's equipment from intrusion by aquatic life forms. A new system was being installed by a third-party contractor on the dock area where the incoming water flows were located. This new skid included its own PLC-based control system.

The data from this new system needed to be monitored by the Distributed Control System within the main plant, which was across a highway and about a quarter mile away at a change of elevation of seven stories. Running a new data line via traditional wiring or fiber was cost-and time-prohibitive.

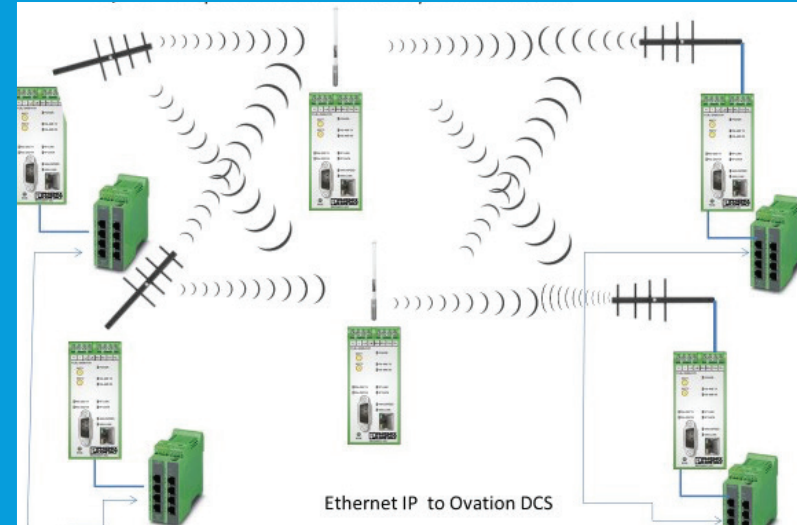

Solution

Rawson/Industrial Controls provided a three-part wireless Ethernet system to bring the customer's PLC data to the DCS control room. Because there was no direct line-of-sight from the dockyard equipment to the control room, a repeater station would be necessary to ensure reliable communications between the PLC and DCS. Since there was no power feed available at the repeater location, a solar-powered control panel was fabricated to provide power to the radio for continuous communications between the controllers. Because this communication is considered critical, a primary/secondary radio arrangement was made which would allow for communication in the event of individual radio failures. Also included were voltage and current sensors to alert the end user if battery voltage or charging current went below specified criteria.

Results

A 900 MHz radio system was employed to maximize distance and minimize obstruction interference. A low-pass filter was employed to block out noise from pager systems utilizing part of the license-free bandwidth. Our engineers were able to design the system to include the solar power with monitoring and redundant radios. Rawson/Industrial Controls' engineering team was able to provide drawings and start up to ensure reliable operation.

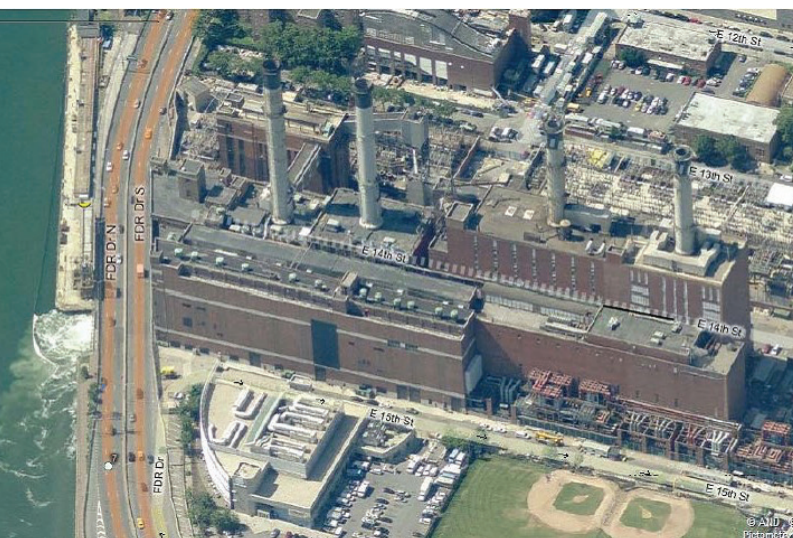

Case Study

Cellular Tank Level Control

Company Profile

This customer is a small municipality in New Jersey.

Challenge

A customer was installing a new domestic water tank for its citizens at a remote location at the top of a hill. The pump lift station that brings water to the tank was located one-half mile away and at a much lower elevation. The pump controls were obsolete and operated off two float switches which were disposed of with the old water tank. The township wanted the ability to know the tank levels and control the pumps, which would allow them to adjust the tank level setpoint at any time.

The remote nature of the application within a residential, wooded area negated the ability to use line-of-site radios, and a project to excavate and bring communications wiring between the two sites was impossible. Remote access was desired, as well, for local management.



Solution

Rawson/Industrial Controls provided a cellular communication system to connect the new tank location to the pump house as well as provide remote access to the end users. A reflective ultrasonic level transmitter was provided to measure the water level in the tank, while being immune to temperature and condensation effects. A panel-mounted controller was provided to cycle the two pumps to maintain the desired level while balancing runtime hours for each pump. A cellular RTU communicates the tank level and control signals to the pump house to control the pumps. Remote cellular access is provided with basic viewing capability.

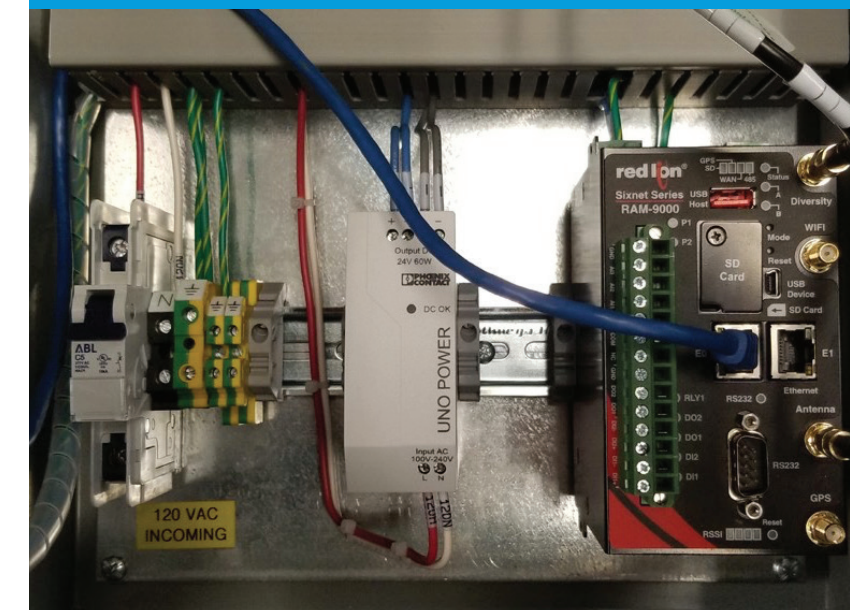

Results

Rawson/Industrial Controls' understanding of the water industry and the challenges faced by instrumentation and controls in the northeast climate helped us to craft a system that will be reliable and flexible for the end user to grow with.

Case Study

Diesel Level Monitoring

Company Profile

This customer is the world's largest developer and manufacturer of medical devices and therapies to treat more than 30 chronic diseases.

Challenge

Our customer produces products in batches that can span hours or even days to complete. During the batch process all process data, including pressures and temperatures, needs to be recorded to ensure product quality and for regulatory reporting.

For the processes that span a long time, there are periods when there is no personnel on site to monitor the recorder for anomalies. When excursions from norms happen when there is no oversight, the batch must be discarded or at best reworked. This is costly in terms of product loss, production time waste, and disposal costs. Also, if a paper jam or other recorder mechanical failure occur, the batch data cannot be proven so the result is a nonconforming batch.



Solution

Rawson/Industrial Controls provided a videographic data recorder without mechanical pens to prevent failure and provide networking capabilities. To monitor the system, SCADA software was provided for on-premise monitoring, and the web-viewing option was enabled to allow engineering to remotely view the process via an iOS-based device. Alarming was included to alert the operator of excursions so corrective action could be taken before production damage occurred.

Results

Rawson/Industrial Controls' expertise in data recording, SCADA software, and communications systems was the basis for creating a hybrid solution of instrumentation and automation products. Our engineering services team put this solution together to provide a robust monitoring system that can be expanded to multiple recorders throughout the customer's facility.

Case Study

Chemical Refining Cooling Water Controls

Company Profile

This customer is a transnational company with activities in three main service and utility areas traditionally managed by public authorities: water management, waste management, and energy services.

Challenge

A waste oil separation and recycling company wanted to make use of their remediated water supply to cool their distilling operations before sending it out to the county sewer. Their chemical refining and distilling processes were being controlled by GE 90-30 PLCs, which were originally installed in the 1990's and were also in need of updating.

The mechanical design of the cooling system required accurate flow control of four distinct lines to maintain the appropriate temperature without overflowing the sump.

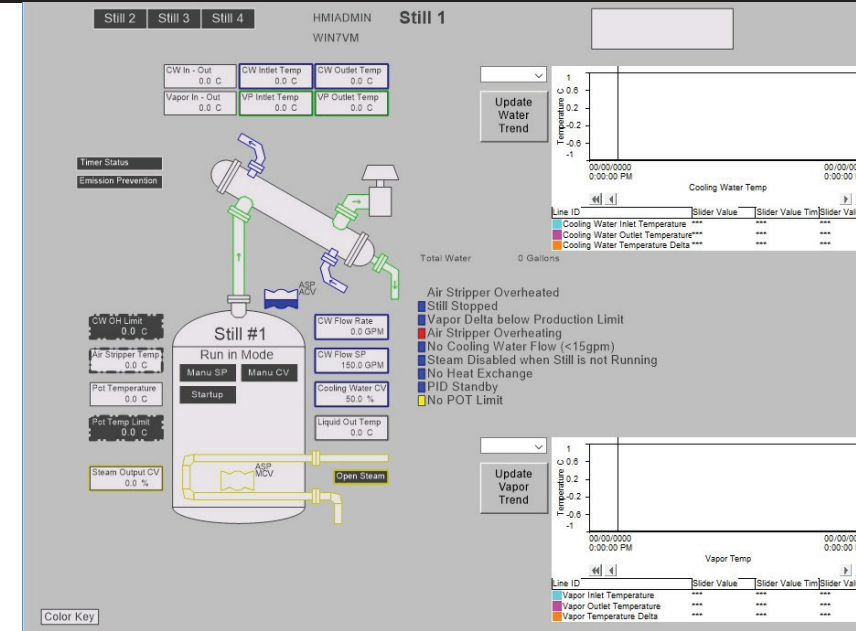

Solution

Rawson/Industrial Controls upgraded the customer's obsolete 90-30 PLCs to the current Emerson RX3i, which is a direct drop in replacement for the 90-30, allowing for re-use of I/O cards and no rewiring. Replacing the serial I/O network with a fiber-optic, high-speed Profinet network allowed for more flexible and reliable I/O communication. Hardware redundancy was added as well with the simple addition of another CPU rack.

Because the migration of Emerson PLCs does not require any reprogramming, Rawson/Industrial Controls' engineering team was able to add the required functionality to control the water-cooling manifold while performing the upgrades.

Results

In addition to providing the automation components and engineering, Rawson/Industrial Controls also specified and supplied the needed temperature instruments and automated control valves that make up the complete system. Rawson/Industrial Controls' history with the installed products, new products, and process systems allowed for an easy transition to a modern control system.

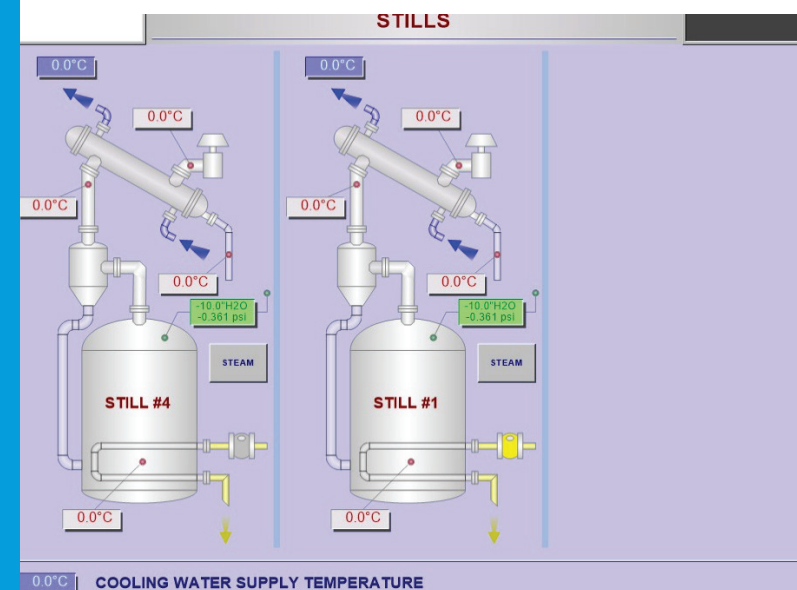

Case Study

PLC-Based Energy Monitoring

Company Profile

This customer delivers sustainable, high-quality, low-cost potable water supply to the current and future communities of its region through water resource development, water purification process innovation, source water protection, and effective asset management.

Challenge

Our customer wanted to be able to monitor power consumption in their pumping facilities. Traditional power meters require a place to be panel mounted, and their communications capabilities are limited to serial point-to-point connections.

It was not cost-effective to modify existing switchgear panels to accommodate panel meters and then to manage the serial data connections into their PLC to gather the needed data.

Solution

Because the water district was using Emerson's RX3i Profinet-enabled PLC, Rawson/Industrial Controls introduced them to the Power Monitoring Module, which has direct connection to CTs and PTs and coprocessing capability to calculate voltages, currents, power use, and more. The Power Monitoring Module can be mounted on the CEP single-slot Profinet I/O platform, allowing the measurement to take place at each breaker location without the need to wire instrumentation back to the PLC cabinet.

Results

With multiple energy monitoring and control solutions, Rawson/Industrial Controls helped the customer select the most cost-effective solution for monitoring their power consumption. In this case, the installed base of Emerson PLCs controlling the pumping operation made for easy integration of the Emerson PLC-based power monitoring equipment.

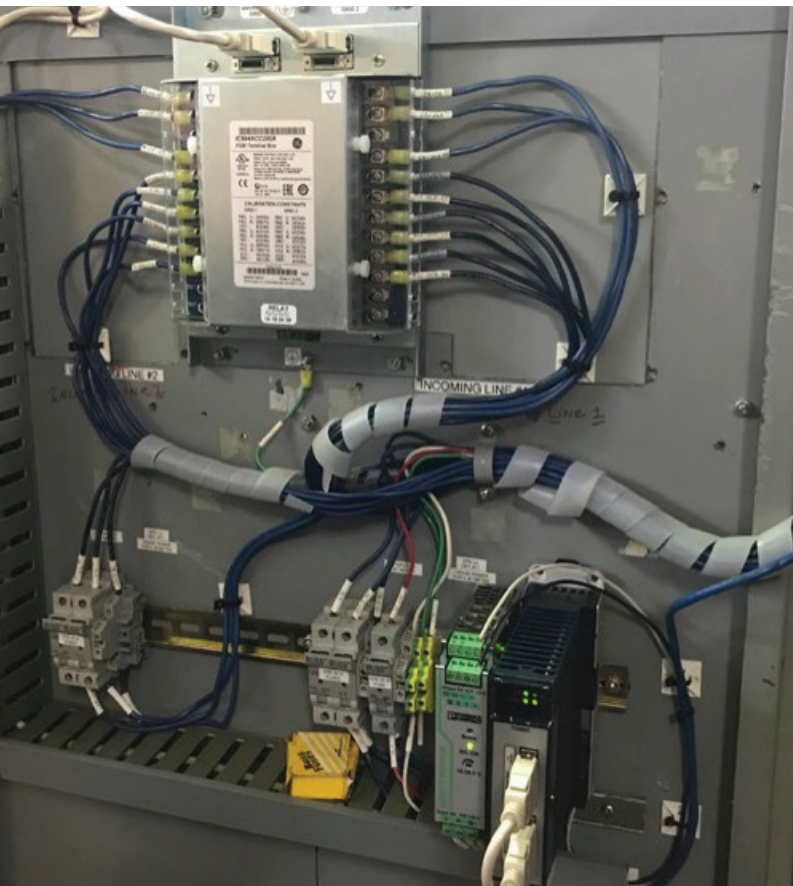

Case Study

Low Cost Redundancy

Company Profile

This customer is a municipality located in New York City.

Challenge

A municipal wastewater facility experienced a failure in one of their obsolete GE 90-30 PLCs, which shut down a considerable part of the plant. The primary CPU that failed was no longer available so options for getting the facility running quickly were limited. The operations staff was not comfortable continuing operations with obsolete controls. The failure also called their attention to the risk inherent in a simplex control system.

Solution

Rawson/Industrial Controls provided a pair of modern RX3i rackless CPUs which are a natural replacement for the obsolete 90-30 PLCs. Also included was the necessary communications equipment to convert the existing 90-30 I/O to remote I/O for the new processors.

Results

The stand-alone processors can operate as a redundant pair eliminating the risk of a future processor failure shutting down the system. Being able to utilize the existing I/O allowed the customer to preserve the existing wiring, avoiding the cost of an electrician rewiring the field signals. A minimal incremental investment of \$4,000 allowed an obsolete simplex system to become a modern, redundant control system. Rawson/Industrial Controls provided technical support so the customer could implement the new system without the need for hiring an outside engineering firm.

PACSystems High Availability with PROFINET and RX3i

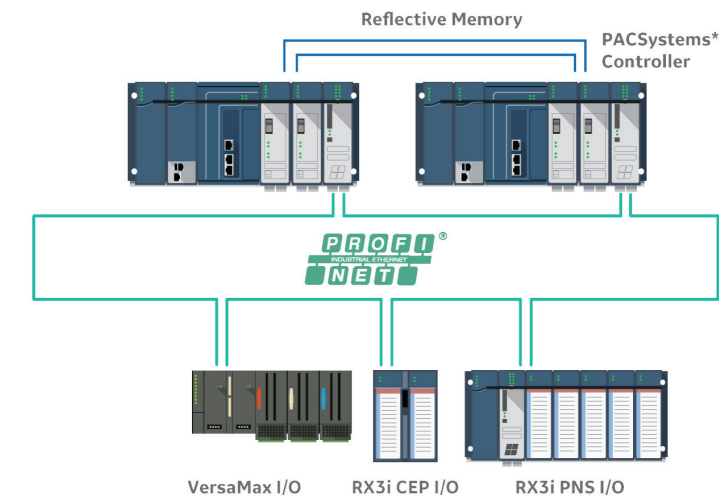

Case Study

Remote Access for PLC Troubleshooting

Company Profile

This customer is the industry leader in developing innovative fire protection systems that help stop the spread of fire, smoke, and hot gases.

Challenge

A manufacturer of specialty building products uses a modified crematorium to heat treat their end product. The process uses Honeywell controls and HMI to control and monitor the process. Because the curing procedure is a time-intensive process, there is much time that the system is running while the facility is unmanned.

A process failure occurred, resulting in the loss of a batch of material at great cost to the company. An early warning of the process excursion could have allowed for intervention that may have saved the batch.

Solution

Rawson/Industrial Controls provided a cybersecure remote access gateway using cellular/cloud technology. The system allows an end user or contracted engineering firm to access the PLC and HMI remotely to view process conditions and alarms, if any. Any authorized plant maintenance, engineering, or management personnel can now troubleshoot the system from any remote location.

Results

The total investment for this project was \$200,000 and was delivered in 10 weeks. The cost of constant loss of steam, excessive heating, and additional labor to maintain and operate the existing system was over \$75,000 per year, creating a 2.6 year ROI.

Case Study

Furnace Setpoint Controls

Company Profile

This customer is a super-heavy forging plant and a leader in the production of open-die forgings.

Challenge

A metal forging company was using a 1980s vintage setpoint and temperature controller to control their furnaces and processing equipment. Past its useful life expectancy, the controller was beginning to fail and could not provide the controls needed to maintain end product quality.

Solution

Rawson/Industrial Controls replaced the aged control system with a modern, modular ramp/soak profile controller with a 15" touchscreen HMI.

Results

The new system not only added more accurate control but offered modern features, such as trending, alarm management, and historical data collection. The touchscreen not only emulates the operation of the previous system so the operators could retain a comfort level with the system but also added a more user-friendly, flexible operating environment.

With a broad range of control products from distributed control systems to PLCs to modular controllers, Rawson/Industrial Controls was positioned to choose the best control strategy for the customer's process rather than trying to fit a solution to a singular product. Our engineering team executed these systems and trained our customer to take ownership of them once the project was complete.

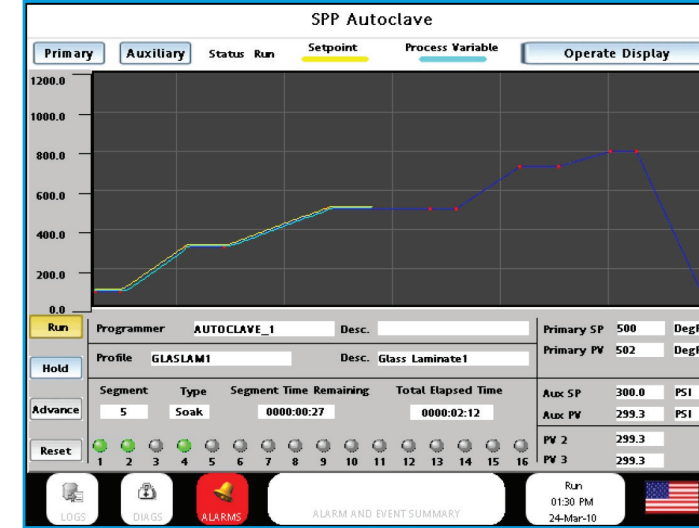

Case Study

Wireless Sump Alarming

Company Profile

This customer is a leading specialty chemicals company with 60 production sites worldwide. They specialize in the development, manufacturing, and marketing of chemical intermediates, additives, specialty chemicals, and plastics.

Challenge

A chemical manufacturer has several reactor areas with equipment in below-grade sumps. Due to weather or equipment mishaps, water frequently enters these sumps and floods the equipment, primarily electric motors in the sumps. Over the past 18 months, 10 pumps have needed to be replaced at an equipment cost of over \$10,000. Also not accounted for is lost production time, and in-house labor to replace the equipment.

The control room operators have no way of knowing there is water present in the sumps until equipment failures trigger alarms. With some earlier notice of water leakage, measures could be taken to remedy the situation before equipment is flooded and damaged.

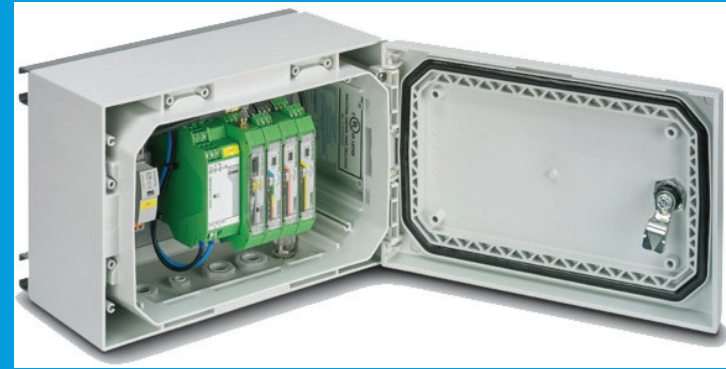

Solution

Rawson/Industrial Controls provided a thermal leak-detection switch for each sump location along with six local control panels with wireless discrete input transmitters. These panels communicate via point-to-point wireless communication to a receiver radio in the control rooms which provides contact alarms to the customer's DCS as well as initiates a horn/strobe alarm to alert the operators of a problem.

Results

Rawson/Industrial Controls' knowledge of level and control applications allowed us to craft a solution from readily available components to supply an annunciation system to work with their current control system. Rawson/Industrial Controls' engineers were able to configure and program the system to the point where the customer can integrate it into their DCS. With mobile test equipment and the willingness to offer a presale site survey, the customer can have a high degree of confidence the solution will work once implemented.

Case Study

Remote Batch Monitoring

Company Profile

This customer is a world leader in the manufacturing of biochemicals and enzymes.

Challenge

A pharmaceutical company produces products in batches that can span hours or even days to complete. During the batch process all process data, including pressures and temperatures, needs to be recorded to ensure product quality and for regulatory reporting.

For the processes that span a long time, there are periods when there is no personnel on site to monitor the recorder for anomalies. When excursions from norms happen when there is no oversight, the batch must be discarded, or at best re-worked. This is costly in terms of product loss, production time waste, and disposal costs. Also, if a paper jam or other recorder mechanical failure occurred, the batch data cannot be proven, so the result is a nonconforming batch.

Solution

Rawson/Industrial Controls provided a videographic data recorder without mechanical pens to prevent failure and provide networking capabilities. To monitor the system, SCADA software was provided for on-premise monitoring, and the web-viewing option was enabled to allow engineering to remotely view the process via an iOS-based device. Alarming was included to alert the operator of excursions so corrective action could be taken before production damage occurred.

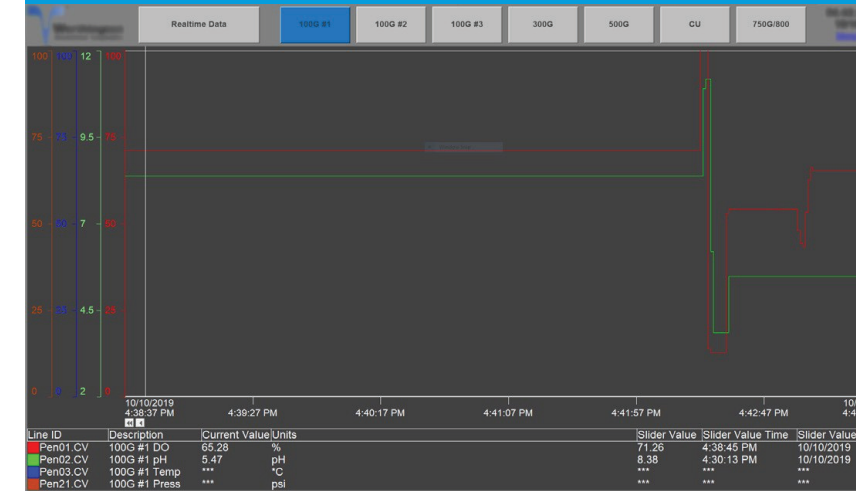

Results

Rawson/Industrial Controls' expertise in data recording, SCADA software, and communications systems was the basis for creating a hybrid solution of instrumentation and automation products. Our engineering services team put this solution together to provide a robust monitoring system that can be expanded to multiple recorders throughout the customer's facility.

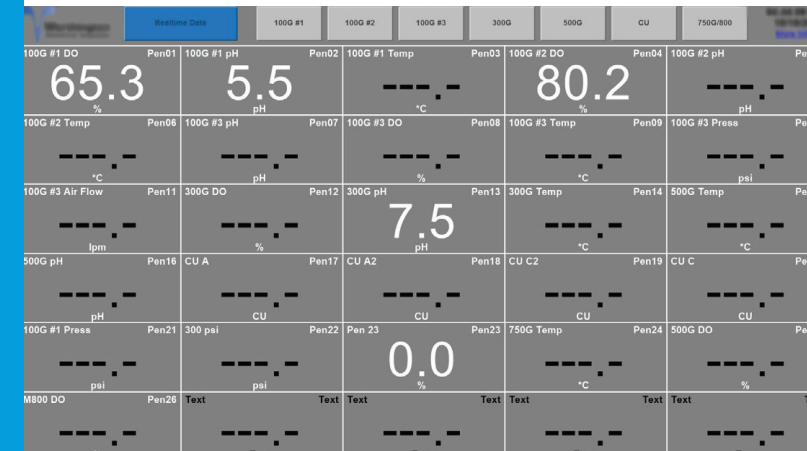

Case Study

Cellular Access of SCADA Screens

Company Profile

This customer has diverse capabilities related to the design and fabrication of electromechanical products and equipment.

Challenge

A manufacturer of pump skids had a customer that wanted the ability to view their SCADA screens remotely through a cellular connection. The skids are controlled by Emerson's RX3i PLC and Cimplicity SCADA software. The end user requires strict adherence to cyber security principles for any public connection.

Solution

Rawson/Industrial Controls provided a cyber secure VPN gateway with cellular connection that is third-party certified to meet cyber security standards. A completely documented control system was provided, shop tested, and field commissioned.

Using GE Cimplicity's Webspace add-in, the manufacturer created screens for remote viewing that allowed the end user to monitor their pump skids and receive alarms as needed for maintenance.

Results

Rawson/Industrial Controls' knowledge of level and control applications allowed us to craft a solution from readily available components to supply an annunciation system to work with their current control system. Rawson/Industrial Controls' engineers were able to configure and program the system to the point where the customer can integrate it into their DCS. With mobile test equipment and the willingness to offer a presale site survey, the customer can have a high degree of confidence the solution will work once implemented.

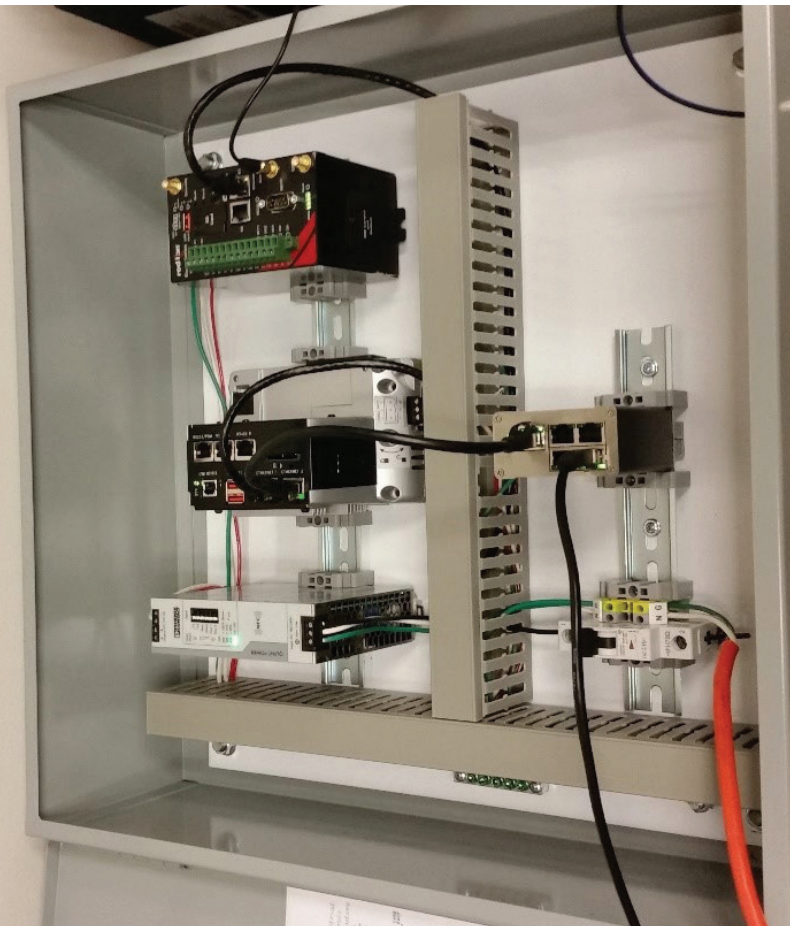

Case Study

Cellular Monitoring of Recorder Data

Company Profile

This customer develops, manufactures, and markets diagnostic products. The company provides a handheld automated blood analysis systems capable of performing blood tests to hospitals, and ambulatory and urgent care facilities.

Challenge

temperature and humidity in each of these rooms must be tightly regulated according to FDA regulations. The data proving that these values remained in tolerance throughout the manufacturing process are recorded in an electronic data recorder.

At times, the data needs to be viewed by company personnel outside of the building. Because all of the equipment is located in the manufacturing area, the customer was unable to remotely access data or receive alerts that parameters were out of tolerance.

Solution

Rawson/Industrial Controls provided a cellular RTU to connect to the customer's paperless data recorder's network port and provide secure access to remote users. The RTU was programmed to send alerts if any of the recorder's parameters was reaching an alarm limit as defined by the customer.

Results

The customer is now aware when process values are trending out of tolerance and can deploy resources to remedy the situation before a reportable event or product loss occurs. Rawson/Industrial Controls has vast experience with both electronic data recorders and cellular communications. We have relationships with several IIoT vendors and the knowledge to implement systems, giving customers remote access and dashboards to their process systems.

SMS Text Message Alarm System

Contact Information

Realtime Data

Alarm Viewer

Communications: Normal
HoneywellSX_Comms: Normal

Active Alarms: 0

Script Execution: 0
Error Script: 0
Alert Script: 0
Alarm Script: 0

Clear Script Count

No Active Alarms

Case Study

LNG Gas Monitoring

Company Profile

This customer is a multinational electricity and gas utility company.

Challenge

A natural gas utility operating a liquified natural gas facility was utilizing obsolete gas detection sensors and relay-based alarm annunciation system. The electromechanical annunciation device was prone to failure and the sensors could no longer be calibrated properly.

In addition to modernizing the gas detection system, the customer desired to have multiple people have access to alarms as they occurred to ensure safe operation of the facility.

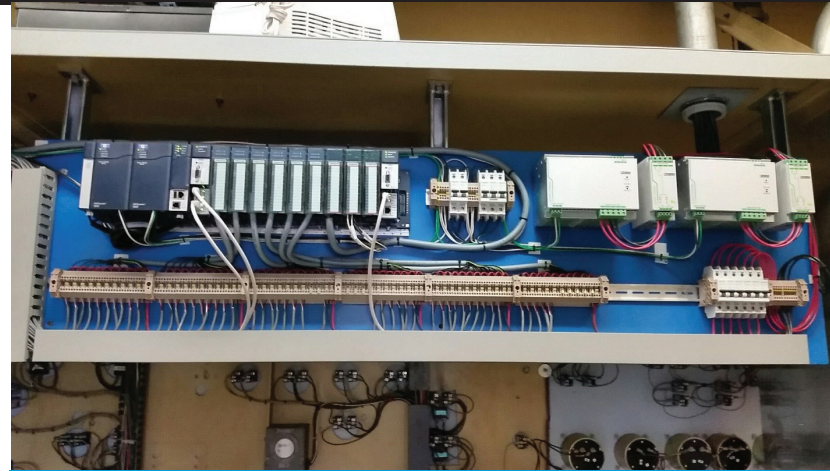

Solution

Rawson/Industrial Controls provided up-to-date infrared methane detectors, which do not require periodic calibration and a PLC/SCADA-based monitoring and annunciation system. Rawson/Industrial Controls provided gas detection startup and automation programming and integration services.

Results

The infrared detectors, once configured, do not require calibration as the traditional catalytic bead sensor do. A PLC-based system is an all-electronic system that is not prone to mechanical failures, such as relay coils and indicating lights reaching end of life. SCADA software annunciation allows for multiple operating stations and remote viewing on phones, tablets, and laptops

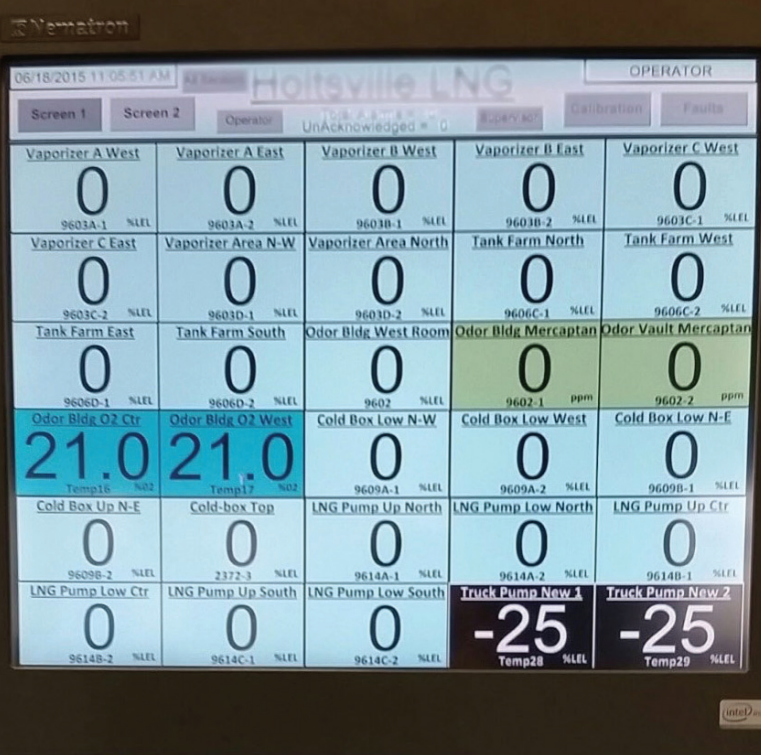

Case Study

Natural Gas Flow Report Generation

Company Profile

This organization is a division of a local county public works which provides the design specifications, construction, repair, maintenance, and security services for all buildings and grounds.

Challenge

NJDEP requires industrial and commercial sites with boilers over 5 million BTU per hour to individually meter, collect, and report to the state the total gas or oil usage for each boiler at the end of each year. The traditional approach is to install mechanical in-line gas meters and take monthly totals on a log sheet, which will then be entered into an Excel spreadsheet. This is very time consuming and labor intensive.



Solution

Rawson/Industrial Controls provided thermal dispersion gas meters which were wired to Honeywell paperless recorders that automatically generate and email a monthly gas usage report. The meters calculate gas flow while compensating for temperature and pressure changes without the requirement of additional temperature and pressure sensors. Honeywell paperless recorders were installed in each building and wired with 4-20 ma inputs from each of the gas meters (Modbus could also have been used). The recorders display historical trends, real-time flow rates, and a running gas usage total for each meter. They also generate a report at the end of each month showing these totals. The report is then automatically emailed to the site director.

Results

The total investment in this project was \$100,000. The cost savings on the decrease in required labor and increase in efficiency was \$37,000, creating a 2.7 year ROI. The project also increased efficiency and removed the possibility of human error.



Case Study

Boiler Energy Savings with Fuel/Air Ratio Controls

Company Profile

This customer is the world's third-largest pharmaceutical medical device manufacturer specializing in cardiac and vascular technologies, restorative therapies and services, and advanced diabetes management solutions.

Challenge

This customer used multiple boilers to supply building heat, hot water, autoclave steam, and process heating steam. The cost of running and maintaining these boilers was considered overhead, so any reduction in cost would directly improve profits.

The boiler controls made use of a traditional, mechanical jack-shaft system, forcing a linear fuel-to-air ratio throughout the demand curve. Peak boiler efficiency, however, is not a linear relationship. Therefore, the boiler runs either too "rich" or too "lean," which results in wasting valuable energy. Because the boilers can be fueled by either natural gas or by oil, the customer is faced with a very time-consuming process to adjust the mechanical system when changing between fuels.



Solution

Rawson/Industrial Controls provided a Honeywell Control Links parallel positioning system, which replaced the mechanical linkage system and allowed for modeling a fuel-to-air ratio curve to match the peak boiler efficiency curve. The mechanical linkages were replaced by individual servo actuators for each of the fuel valves and air damper. The electronic touch screen controller was programmed to control each of the servo actuators independently at every point in the demand curve, allowing the fuel-to-air ratio to be optimized during any steam demand condition. The system adjusts automatically when a change in fuel occurs.

Additional benefits derived from this solution:

- Reduced fuel usage (6%-8% of annual fuel used).
- "One-touch" fuel changeover procedure, reducing operations personnel time required to adjust the system when change from gas to oil is required.
- Reduced exhaust stack temperature, an environmental benefit.
- Reduced emissions stemming from efficient combustion, an environmental benefit.

Results

The total investment in this project was \$45,000 and it took eight weeks to complete all three boilers. Annual energy savings is estimated at \$18,000 per year, and additional savings in labor were reported for the several hours that were required for adjusting the traditional jack shafts when a change in fuel occurred.



Case Study

Automated Alarm Annunciator for Substation Control Room



Company Profile

This large regional power-distribution company operates below ground high-voltage electrical power transmission lines. They are responsible for safe distribution of power to their clients.

Challenge

The traditional means of alerting control room operators is through annunciator panels. The alarms come in through a series of electromechanical relays. These relays are usually operated off 125VDC station power and are costly to wire and replace when failures occur. The operator does not know if a relay or lamp has failed so alarm conditions in the facility may go unannounced. Since these alarm relays are hard-wired, any changes to the alarm groupings requires a shut down and re-wiring of the relay panel.



Solution

Rawson/Industrial Controls provided a GE PAC Systems RX3i automation system to replace the electro-mechanical relays in the system. The RX3i controller accepts 125VDC inputs directly, eliminating the need for interposing relays. To monitor the alarms, Rawson/Industrial Controls provided two licenses of GE Proficy Machine Edition View SCADA software. These HMIs are installed on industrial PCs and are located at the control panel as well as on the operator's desk.

Results

The PAC-based automation system needs far less panel space, is fully programmable to allow changes in alarm strategy at any time, and provides self diagnostics so that operators are aware of any hardware failures that result in unannounced alarms. The HMI program allows multiple locations of alarm annunciation, providing redundancy and more eyes on problems. Unplanned outages have been avoided.

Case Study

Wireless Monitoring of Electrical Substations - Dielectric Oil Pressures and Levels



Company Profile

This company is one of the largest energy companies in the United States, with approximately \$13 billion in annual revenues and over \$36 billion in assets. In 2005, electric revenues accounted for 64.9% of consolidated sales (68.3% in 2004).

Challenge

Major metropolitan electrical substations require the ability to monitor levels of their dielectric fluid pumping stations, and pressures of their high-voltage electrical transmission terminals (potheads). This requirement is usually accomplished by having personnel manually retrieve process values from gauges located throughout the substation. This is not only dangerous, but also time-consuming and inefficient.



Solution

Rawson/Industrial Controls provided a wireless solution for this application which allows safe, reliable, real-time monitoring of pothead pressures, as well as tank levels of dielectric oil. The solution included a Honeywell OneWireless system, Honeywell XYR series wireless transmitters, and a local Emerson HMI. Rawson/Industrial Controls performed start-up, testing, and programming services to ensure the safety and reliability of the system.

Additional benefits derived from this solution:

- Battery-powered transmitters can easily be installed anywhere in the plant, without running wires or conduit.
- Transmitter batteries last 3-5 years, making the system easy to maintain.
- Transmitters can be configured as routers to enhance wireless signal reliability and range.
- The base radio can provide data in nonproprietary formats, such as OPC or Modbus.
- All wireless communications conform to ISA100 wireless standard, which is the most secure and reliable industrial wireless technology available today.
- The HMI is fully customizable to the customer's specification and is easily expandable.

Results

The total investment of this project was \$150,000, while the alternate wired solution would have required a \$300,000 investment. Data is now displayed in the control room for operators, which eliminates the manual labor required to check mechanical gauges. This yielded a savings of \$73,000 per year to net a 2-year ROI, as well as the priceless savings obtained from decreased downtime and increased safety.

Case Study

Transportation System Data Logging



Company Profile

This customer has the largest subway systems in North America, consisting of over 500 stations managing over 5,000 rail cars. In excess of 5 million customers per day use this system, so safety, reliability, and uptime are of utmost importance. When unplanned events occur, it is critical that quick decisions are made. Having the data easily accessible and in the right place is vital to smooth operations.

Challenge

As cars enter and exit stations, several hundred events occur and need to be recorded quickly and accurately. The currently-installed system monitors the activity of all trains entering and leaving various stations through a large area network to a central system. Each station also has one or more stand-alone data recorders which serve as duplicate data recording devices. These recorders cost well over \$10,000 each, are large, outdated, and unreliable, and do not provide a method for retrieving data in the event of a network outage.

Solution

The Rawson/Industrial Controls solution involves the use of an ultra-reliable solid state industrial computer and compact I/O modules which occupied roughly half the installation space. In many cases, these industrial computers can perform the tasks of multiple recording devices as a single system. In the event of network outages, the system buffers data and fills in the gaps in the central database when communications are re-established. Additionally, in the event of a long term outage, an operator can retrieve data locally via a standard USB memory device and analyze the data using standard tools, such as Microsoft Excel. The extraction of data is achieved either through a smart phone app or laptop computer using a simple interface which permits the user to easily select the time range and data points to be retrieved. This data can then also be reinserted into the central system, allowing for playback of events.

Results

When all new systems are installed, between \$500,000 and \$1,000,000 will be saved in hardware costs alone. The new system will enable faster response time, guaranteed data integrity, and fewer required resources.



Case Study

Radar Level for Sewage Lift Stations

Company Profile

Located in Central NJ, this medium-sized utility authority maintains the sewer and water services for roughly 40,000 residents over a 40-acre area.

Challenge

Wastewater lift stations are designed to move wastewater from lower to higher elevations when there is insufficient gravity flow. One of the key elements of the lift station is the “wet well,” whose level is monitored and controlled so that the sewage can be gravity fed back to the central treatment plant. A level sensor is used to monitor the wet well level so that if an overflow condition is detected, the sewage pumps are automatically turned off.

The traditional approach is to use a submersible level sensor. Rags and other heavy paper debris can enter the sewage pipes and tend to wrap around and clog the submersible sensor. This can prevent the sensor from accurately measuring the level and cause an overflow. For this reason, back-up level float switches are usually installed to shut down the pumps if the submersible sensor fails to detect a high level.

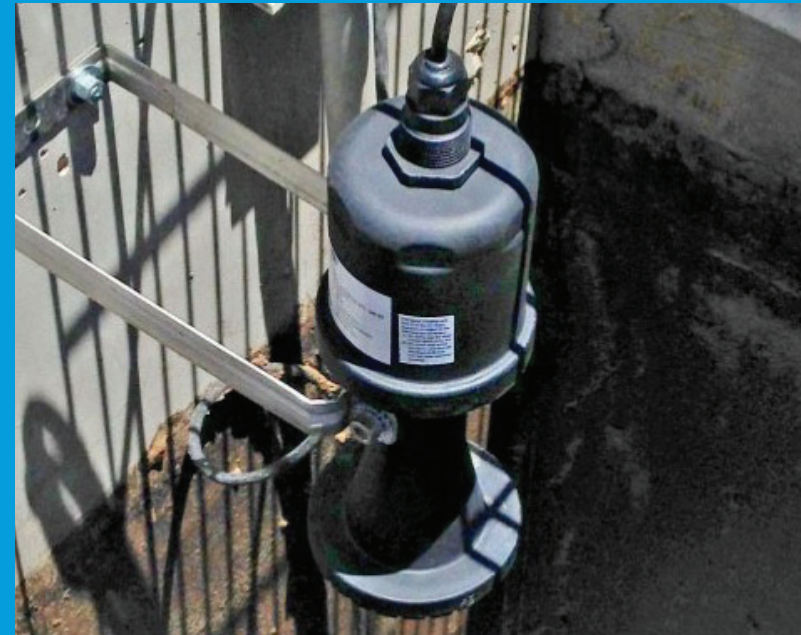

Solution

Rawson/Industrial Controls provided a better solution to detect the level by using a non-contact radar level transmitter mounted above the highest point in the wet well. These sensors are designed to operate outside and in tough environmental conditions, and are also available in a submersible design. The radar level transmitter sends its output to the same lift station control system without the associated cost of reengineering the system. While a backup level sensor may also be installed, they are prone to failure due to their contact with debris in the system.

Results

Installation of a radar sewage level sensor reduces maintenance and troubleshooting expense due to the tendency of submersible sensors to clog. This distracts from other preventative maintenance activities and expenses associated with the risk of spill cleanups and EPA fines. The installation of an entire fleet of radar level sensors will pay for itself by avoiding a single event.



Case Study

Burner Management Systems

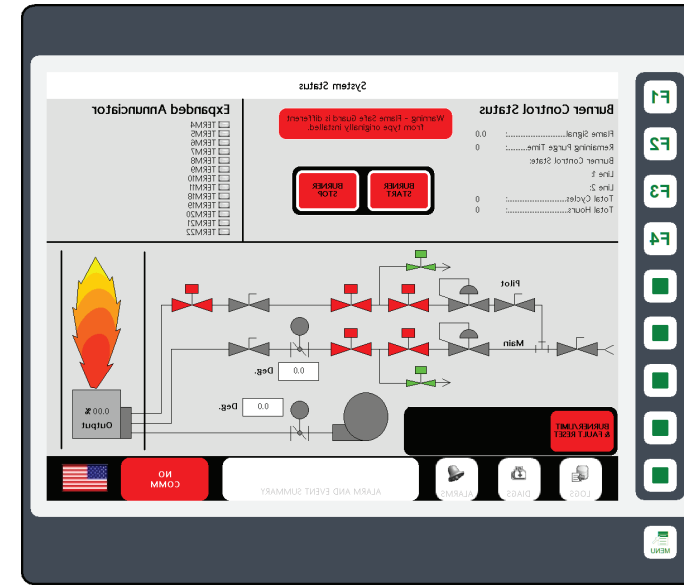

Company Profile

A Wisconsin-based company that mills corn ingredients and uses the corn waste to produce biofuels like ethanol. Their products serve the world from high-quality ingredients to famine relief. Their waste stream from the milling process is utilized as the starter for the ethanol product.

Challenge

To provide communications with burner management systems to help maintenance personnel in troubleshooting burner management shutdowns and, therefore, cut down the number of shutdowns. Maintenance personnel were struggling to understand the failures in their burner management systems and were unable to discover on-going shutdowns that often reflected deferred maintenance but created lost production time.

Solution

Rawson/Industrial Controls provided programming, configuration, wiring diagrams, products, and other expertise in their burner and burner management systems. Utilizing the Honeywell HC900 with some custom programming and a user display paired with either the Honeywell or Fireeye flame safeguards, the maintenance personnel were able to get an on-going view into their burner management system. They now can log the flame safeguard shutdowns to help personnel troubleshoot, which will lead to fewer shutdowns and save production time.

Results

The ethanol plant was able to greatly reduce the number of shutdowns caused by repeated problems with their burners. The company was able to schedule standard maintenance during planned shutdowns. During unplanned shutdowns, they now can quickly find the problems and get the systems back up and running.

Case Study

Liquid Temperature Control

Company Profile

A boutique Wisconsin-based specialty chemical company.

Challenge

The chemical company needed to ramp up production of a new food supplement product that required fine temperature control of a liquid in a large glass globe which boiled alcohol. The alcohol contained the solid Ketone product they wanted to sell as the supplement and recover the alcohol to reuse. The liquid was held under vacuum and heat was added to speed the process up while continually mixing it.

The original glass globe had broken when the existing controls added too much heat into the glass resulting in the loss of thousands of dollars. The challenge was to provide a flexible control system that would provide fine control of the temperature of the liquid, limit the amount of power to the electric heaters under and around the globe at varying levels, and protect the system in the event the controls failed.

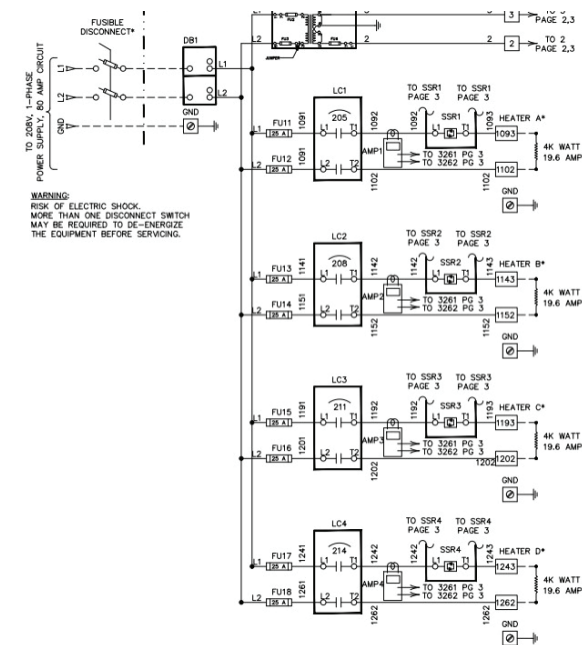

Solution

Rawson/Industrial Controls provided engineering, configuration, wiring diagrams, instruments, sensors, prebuilt and tested panels, start-up and other expertise to control their system. With a mix of stand-alone instruments and properly sized control systems, the customer was able to mount a panel outside of the explosion-proof area and control the existing electric heaters with a very fine control. Users are able to limit the number of heaters that are on depending on the amount of product in the glass globe and regulate the temperature of the liquid. They can limit the amount of heat provided to each heater independently, which allows for less burning of the product on the bottom and finer control as the liquid alcohol evaporates, and slows down the evaporation process to allow the best alcohol evaporation without carryover.

Results

The chemical plant was able to run the multiday process unattended at night to speed up the total processing time by days, which resulted in less energy being used because the globe did not have to be reheated every morning. There was a much greater level of safety by not cracking the globe.

Case Study

Reliable, Accurate, Efficient Solution

Company Profile

A Northeastern Pennsylvania-based manufacturer of components for the Department of Defense.

Challenge

Originally, the manufacturer was looking to replace paper chart recorders with a modern solution that allowed increased detail, customization, and remote access without paper. The Rawson/Industrial Controls Sales and Automation team recommended a Historian solution providing a custom panel that could be placed on a cart and wheeled around to the station that required history to be captured while their manufacturing process ran. The customer was very happy with the solution that was customized and delivered.

Over the holiday break, a fire broke out at the customer site, destroying a large portion of equipment and roof structure. Water damage from firefighting added to the problem. This facility has a single large gas furnace, several electric heat-treating ovens, an Autoclave station, a conveyor system for moving product into the furnace, and much more.

Solution

Due to the excellent Historian solution that was delivered, the customer was open to upgrading instead of replacing their equipment. Many of the processes were run by relays and small universal controllers prior to the fire. Process control was just barely meeting the mark. The Rawson/Industrial Controls team recommended installing Honeywell HC900 units in the oven applications that would provide them with precise control, controlling all the ovens in a given area, allow expansion, and provide them with remote access to monitor and control. PLC's were utilized in the other areas providing the same benefits as above. All solutions consisted of custom cabinets, controls and screen layouts.

The solutions provided by the Rawson/Industrial Controls Automation Engineering group delivered cost savings through precise process control, potentially eliminating bad product batches due to the current process control failures or inaccuracies. Rebuilding 1980s technology is very labor intensive, costly to duplicate, and would have yielded inferior products to the solution that was ultimately delivered. Remote access saved the customer time and money by not having an employee come into the plant to start an oven warm-up, monitor a process, or tweak a run. Remote access also allowed Rawson/Industrial Controls Automation Engineers to troubleshoot any issue that arose from their office, eliminating a cost to the customer.



Before

After

Results

The customer claims had to be approved through an insurance claim review, so Rawson/Industrial Controls assisted with providing information on cost savings, reliability, increased accuracy and meeting current codes at a cost close to simply replacing old technology.

Rawson/Industrial Controls offers a complete inventory of the industry's finest products from the leading manufacturers in our primary coverage area of 32 States. Our products and services are provided to territories that include the Gulf Coast, Mid-Atlantic, Midwest, Northeast, Southeast, and Southwest regions of the United States.

Our secondary coverage area represents a territory where we do not currently have brick and mortar locations but are still able to service this area.

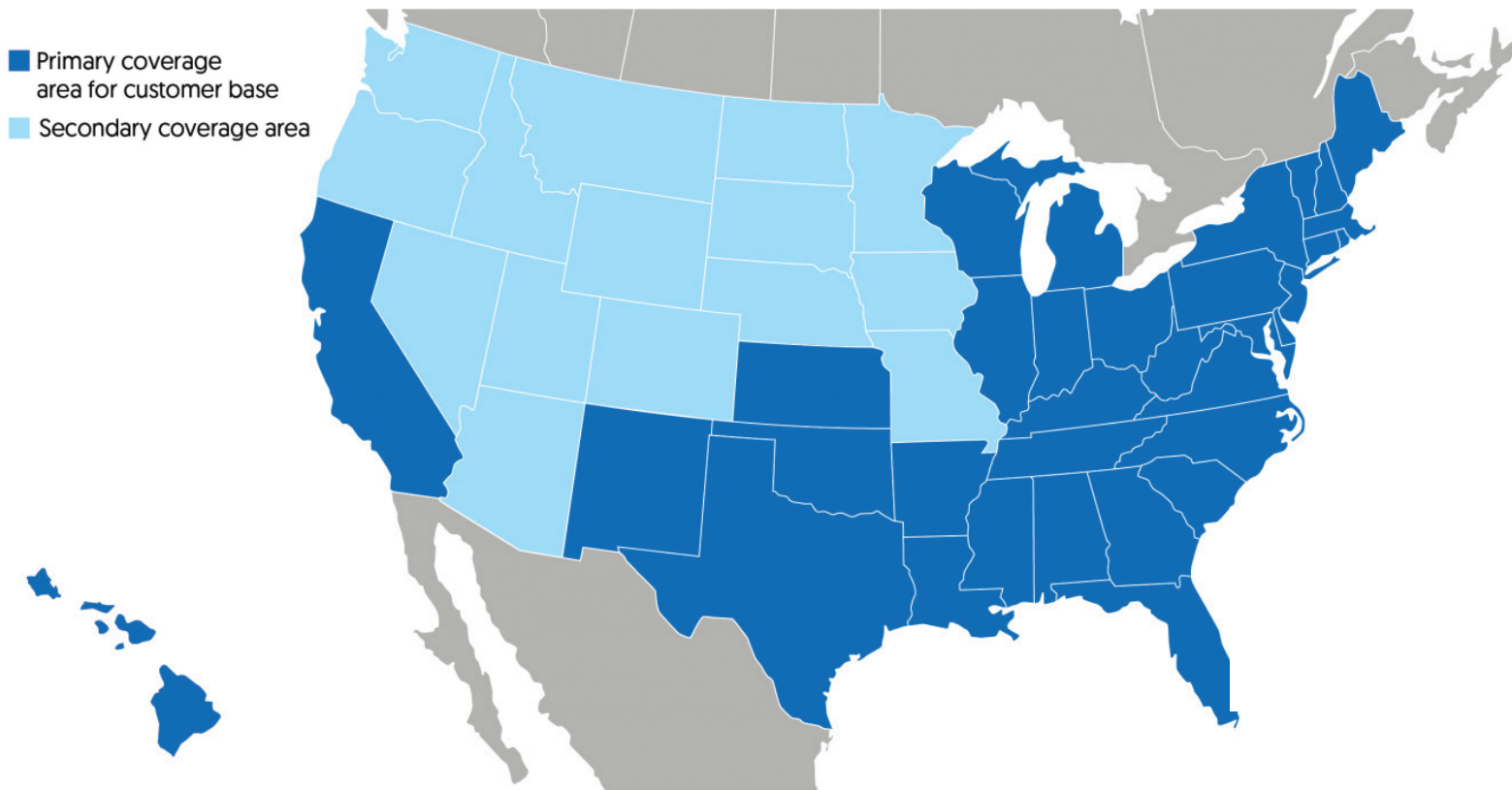

www.rawsonicd.com
1-800-779-1414

Analytical • Filtration • Industrial Automation • Instrumentation
Steam/Energy Management & Technology • Valves & Actuation

Rawson | **Industrial Controls**

a relevant.com company