

Honeywell

MAXON

400 OVENPAK® -II 400 Gas Burners

TECHNICAL CATALOG



Model 415 OVENPAK®-II Burner shown with customer's UV scanner mounted

- **Burns any clean fuel gas**
- **Fires into passing air streams**
- **Requires only low pressure gas**
- **Provides clean combustion with low NOx levels**
- **New modular burner design provides easier installation**
- **Simple field adjustment and maintenance**

Model "400" OVENPAK®-II Burner applications include: Air heating in ovens and dryers, paint finishing lines, paper and textile machines, food baking ovens, coffee roasters, grain dryers, and fume incinerators. Manufactured under U.S. patent #3,574,508; Canadian #873,695; and European patent granted and pending.



32M-01003-02

MODEL "400" OVENPAK®-II GAS BURNERS

Provides application flexibility with:

- 40:1 turndown or more
- Over 16 different styles and sizes
- Heat releases to 16,500,000 Btu/hr
- Cost-effective external blower (EB) version



Fig. 1. Model EB-3 OVENPAK®-II shown with customer's UV scanner mounted

Typical piping layout with "Block and Bleed" gas train arrangement

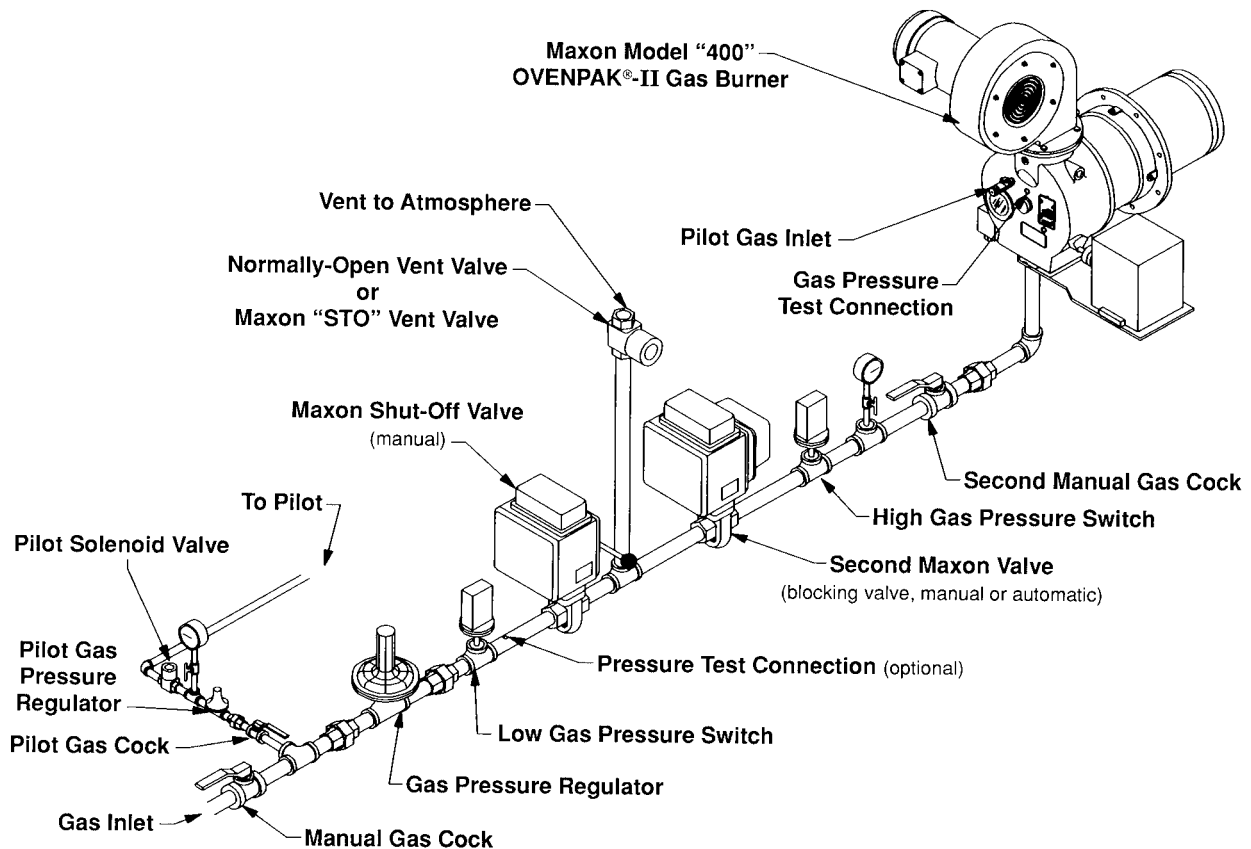

DESIGN AND APPLICATION DETAILS

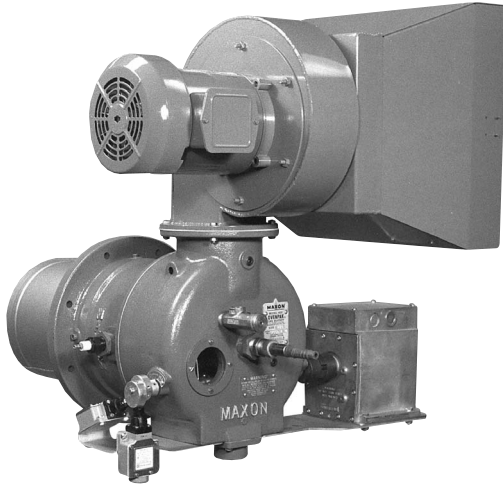

Fig. 2. Model 415 OVENPAK®-II Gas Burner with optional combustion air filter, high and low fire position switch set, spark ignitor, provision for customer's UV scanner and with connecting base and linkage for electrical control motor.

OVENPAK®-II Burners are nozzle-mixing gas burners for many industrial direct-fired applications where clean combustion and high turndown are required. They are simple and versatile for use on a variety of heating applications.

The Model "400" OVENPAK®-II Burner (shown at right) includes a face-mounted motor, blower with non-sparking paddle wheel-type impeller, pilot, spark ignitor, stainless steel discharge sleeve, mixing cone, self-contained internal air and gas proportioning valves, and provision for your flame safeguard sensor.

The blower housing can be rotated and mounted in three alternate locations in 90° increments around the burner air inlet center line. Control motor and low fire start switches may be mounted on either the right or left hand side of burner body..

Principle of operation

The OVENPAK®-II Burner is designed for industrial air heating applications. It is available in two basic versions: 1) packaged with integral combustion air blower, or 2) for use with an external blower. Both versions include a gas and air valve, internally linked together to control the gas-air ratio over the full operating range. The gas flows through the nozzle, then along the inside of the burner cone where combustion air is progressively and tangentially mixed with the gas. This produces a very wide turndown range and a highly stable flame under a variety of operating conditions.

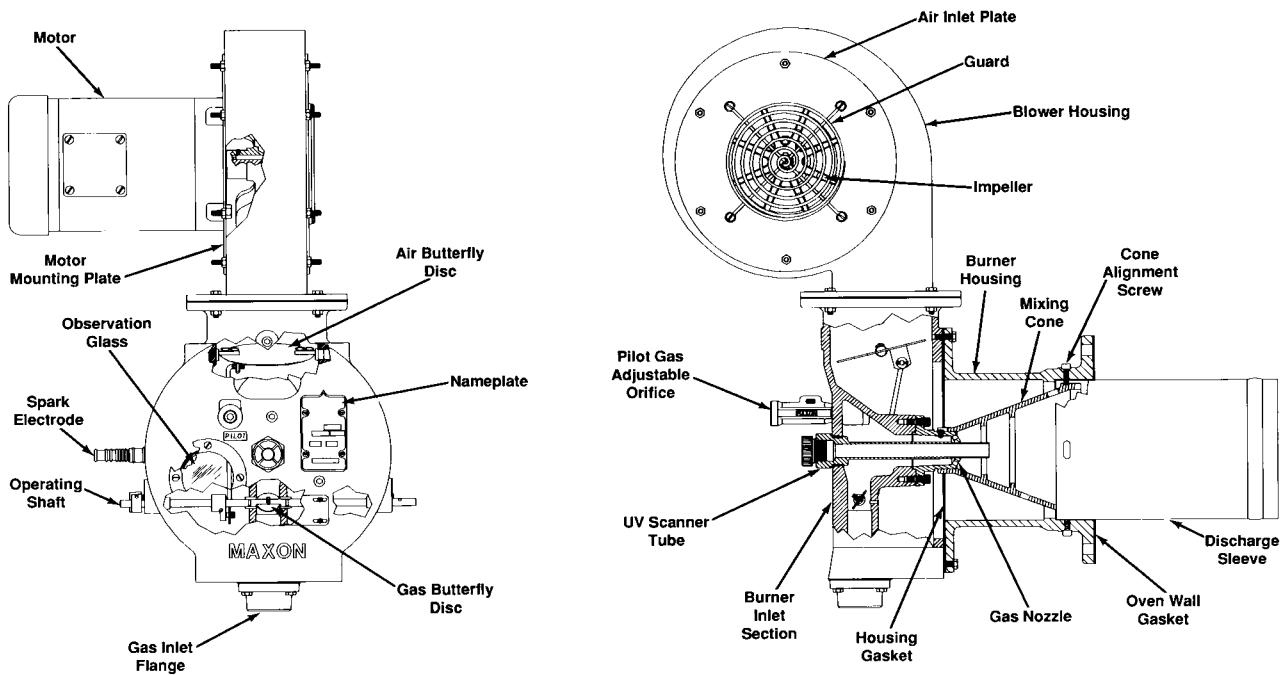

Fig. 3. Cross-sectional views of a Model "400" OVENPAK®-II Gas Burner

DESIGN AND APPLICATION DETAILS



Fig. 4. View into metallic cone of Model EB-3 OVENPAK®-II Burner, arranged for external blower source, with connecting base and linkage assembly to adapt customer's automatic control motor, and optional low fire start switch arrangement. Inlet air piping uses flexible connector set.

Model “EB” (external blower) OVENPAK®-IIBurners (shown in photos), like all OVENPAK® Burner assemblies, are designed to deliver heat through a patented mixing cone and stainless steel sleeve.

Flanged burner body design on all OVENPAK® Burner assemblies simplifies mounting and installation on your application. Burner can be installed in any position that does not conflict with your control motor or flame detector requirements.

Minimal torque requirements permit use of most electric or air operators in conjunction with the optional (MAXON supplied) connecting base and linkage assemblies.

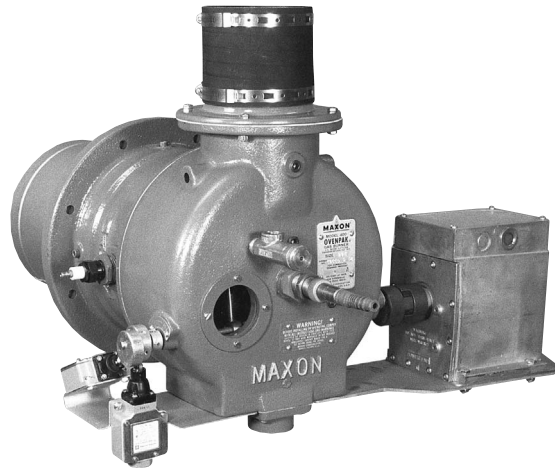

Fig. 5. Model EB-3 OVENPAK®-II Burner with large viewing port, spark ignitor, standard pilot gas adjustable orifice, optional low fire start switch arrangement, and connecting base and linkage for mounting customer's control motor

CAPACITIES AND SPECIFICATIONS

Standard Model “400” OVENPAK®-IIBurner includes a combustion air blower with face-mounted motor.

Maximum capacity of Model “400” OVENPAK®-II Burner is affected by the static pressure within the combustion chamber. Data shown assumes firing in the open, or into an airstream with enough oxygen to complete the combustion process. If burner is fired into an oxygen-starved chamber or airstream, capacities may be reduced as much as 25-30%. Do not attempt to operate beyond the duct static pressure range shown. For higher back pressure applications, select from Model “EB” OVENPAK®-II Burner options.

All gas pressures are differential pressures and are measured at the gas pressure test connection on the backplate of each OVENPAK®-II Burner. Differential pressures shown are approximate.

Motor Voltages Available (60 Hz & 50Hz)

Horsepower	Type	60 Hz	115/208-230/1/60	208-230/460/3/60	575/3/60
		50 Hz [1]	190-200/1/50	380-415/3/50	500/3/50
1/3	Totally Enclosed		X	X	X
3/4 HP & 1 HP	Totally Enclosed		X	X	X
1-1/2 HP, 2 HP & 3 HP	Totally Enclosed		Not Available	X	X

[1] Possible net extra cost

For operation on 50 Hz, reduce OVENPAK®-II Burner capacities by 83% and pressures to 70% of those shown.

Capacities and Operating Data

OVENPAK®-II Burner Model		405	408	415	425	435	445	456	470	487	
Motor Specification	Horsepower:	1/3	1/3	1/3	3/4	3/4	1	1-1/2	2	3	
	Frame Number:	56C	56C	56C	56C	56C	56C	143TC	145TC	145TC	
Maximum Capacities (1000's Btu/hr) with Natural Gas Pressures ("wc)	Duct Statics	-5.0 to -0.5" wc	550 2.8"	880 3.4"	1650 1.7"	2750 2.7"	3850 2.2"	5175 3.4"	6400 3.6"	8050 3.7"	10060 4.6"
		±0" wc	500 2.3"	800 2.8"	1500 1.4"	2500 2.2"	3500 1.8"	4500 2.6"	5600 2.8"	7000 2.8"	8700 3.4"
		+1.0" wc	475 2.1"	760 2.6"	1425 1.3"	2375 2.0"	3325 1.6"	4280 2.3"	5340 2.3"	6570 2.5"	8400 3.2"
		+2.0" wc	450 1.9"	720 2.3"	1350 1.1"	2250 1.8"	3150 1.4"	4125 2.2"	5200 2.4"	6300 2.3"	8200 3.0"
		+3.0" wc	-	-	-	-	-	-	5000 2.2"	5500 1.7"	7500 2.5"
		+4.0" wc	-	-	-	-	-	-	4600 1.9"	5000 1.4"	6200 1.7"
		+5.0" wc	-	-	-	-	-	-	4100 1.5"	4500 1.2"	5500 1.4"
		+6.0" wc	-	-	-	-	-	-	-	3500 0.7"	5000 1.1"
Minimum Capacities (1000's Btu/hr)	Main plus pilot	15		37	60	87	110	125	150	175	
	Pilot only	10		20	35	45	90	105	115	117	
Required natural gas differential pressure to burner inlet ("wc)		2.8	3.3	3.0	2.4	2.7	3.5	5.1	5.2	7.6	
Approximate flame length in still air		1/2 to 1 ft.		2-1/2 to 3-1/2 ft.		3-1/2 to 5 ft.	4 to 6 ft.	5 to 7 ft.	6 to 8 ft.	8 to 10 ft.	

CAPACITIES AND SPECIFICATIONS EXTERNAL BLOWER (EB) VERSIONS

Models EB-1, EB-2, EB-3, and EB-4 OVENPAK®-II Burners

EB-1 OVENPAK®-II Burner	Combustion and Cooling Air Required	Differential Air Pressure ("wc)	3	4	5	6	8	9	10	11
		Volume (SCFM)	150	170	190	210	240	255	270	280
	Heat Releases (1000's Btu/hr)	Maximum Capacity	460	580	715	780	870	910	960	1000
		Minimum & pilot	60	60	60	60	60	60	60	60
		Pilot only	45	45	45	45	45	45	45	45
	Natural Gas Differential Pressures ("wc)	At burner inlet	2.1	3.4	5.1	6.1	7.6	8.3	9.2	10.0
At burner gas test connection		2.0	3.1	4.7	5.6	7.0	7.6	8.5	9.2	
Flame Lengths	In still air	4" to 15" beyond end of discharge sleeve								

EB-2 OVENPAK®-II Burner	Combustion and Cooling Air Required	Differential Air Pressure ("wc)	3	4	5	6	8	9	10	11
		Volume (SCFM)	220	250	280	310	355	375	395	415
	Heat Releases (1000's Btu/hr)	Maximum Capacity	750	980	1200	1330	1450	1500	1550	1600
		Minimum & pilot	60	60	60	60	70	70	75	80
		Pilot only	25	25	25	25	30	30	35	35
	Natural Gas Differential Pressures ("wc)	At burner inlet	3	5.2	7.8	9.5	11.3	12.1	12.9	13.8
At burner gas test connection		2.5	4.2	6.3	7.7	9.2	9.8	10.5	11.2	
Flame Lengths	In still air	12" to 30" beyond end of discharge sleeve								

EB-3 OVENPAK®-II Burner	Combustion and Cooling Air Required	Differential Air Pressure ("wc)	3	4	5	6	8	9	10	11
		Volume (SCFM)	350	405	455	495	575	615	650	675
	Heat Releases (1000's Btu/hr)	Maximum Capacity	1620	1900	2120	2320	2670	2840	3000	3150
		Minimum & pilot	90	95	105	115	130	140	150	155
		Pilot only	45	45	50	55	65	70	75	75
	Natural Gas Differential Pressures ("wc)	At burner inlet	4.1	5.6	7.0	8.3	11.0	12.5	13.9	15.4
At burner gas test connection		1.6	2.2	2.8	3.3	4.4	5.0	5.6	6.2	
Flame Lengths	In still air	2 to 3 feet beyond end of discharge sleeve								

EB-4 OVENPAK®-II Burner	Combustion and Cooling Air Required	Differential Air Pressure ("wc)	3	4	5	6	8	9	10	11
		Volume (SCFM)	550	635	710	775	895	950	1000	1050
	Heat Releases (1000's Btu/hr)	Maximum Capacity	2230	2800	3230	3500	3950	4150	4330	4600
		Minimum & pilot	100	115	130	140	160	170	180	190
		Pilot only	40	40	40	45	50	55	55	60
	Natural Gas Differential Pressures ("wc)	At burner inlet	2.5	3.7	4.9	5.8	7.4	8.1	8.8	10.0
At burner gas test connection		1.9	2.8	3.7	4.3	5.5	6.1	6.6	7.5	
Flame Lengths	In still air	2-1/2 to 3-1/2 feet beyond end of discharge sleeve								

CAPACITIES AND SPECIFICATIONS EXTERNAL BLOWER (EB) VERSIONS

Model EB-5, EB-6, and EB-7 OVENPAK®-II Burners

EB-5 OVENPAK®- II Burner	Combustion and Cooling Air Required	Differential Air Pressure ("wc)	3	4	5	6	8	9	10	11
		Volume (SCFM)	665	770	860	940	1080	1150	1210	1270
	Heat Releases (1000's Btu/hr)	Maximum Capacity	2940	3500	3980	4420	5130	5450	5740	6000
		Minimum & pilot	155	180	200	220	255	270	285	300
		Pilot only	25	30	35	35	40	45	45	50
	Natural Gas Differential Pressures ("wc)	At burner inlet	2.2	3.1	4.0	4.9	6.6	7.5	8.3	9.1
		At burner gas test connection	1.3	1.8	2.3	2.9	3.9	4.4	4.8	5.3
	Flame Lengths	In still air	3 to 5 feet beyond end of discharge sleeve							

EB-6 OVENPAK®- II Burner	Combustion and Cooling Air Required	Differential Air Pressure ("wc)	3	5	8	11	16	18	22	24
		Volume (SCFM)	975	1260	1590	1870	2250	2390	2640	2760
	Heat Releases (1000's Btu/hr)	Maximum Capacity	4710	6700	9500	11200	13500	14300	15800	16500
		Minimum & pilot	335	390	490	575	695	735	815	850
		Pilot only	100	100	100	115	140	145	165	170
	Natural Gas Differential Pressures ("wc)	At burner inlet	2.8	5.6	11.3	15.7	22.8	25.6	31.3	34.1
		At burner gas test connection	2.0	4.0	8.1	11.2	16.3	18.3	22.3	24.3
	Flame Lengths	In still air	3 to 8 feet beyond end of discharge sleeve				8 to 12 feet beyond end of discharge sleeve			

EB-7 OVENPAK®- II Burner	Combustion and Cooling Air Required	Differential Air Pressure ("wc)	3	5	8	11	16	18	22	24
		Volume (SCFM)	975	1260	1590	1870	2250	2390	2640	2760
	Heat Releases (1000's Btu/hr)	Maximum Capacity	4710	6700	9500	11200	13500	14300	15800	16500
		Minimum & pilot	335	390	490	575	695	735	815	850
		Pilot only	100	100	100	115	140	145	165	170
	Natural Gas Differential Pressures ("wc)	At burner inlet	1.8	3.6	7.3	10.1	14.8	16.6	20.2	22.1
		At burner gas test connection	1.0	2.0	4.1	5.6	8.2	9.2	11.2	12.2
	Flame Lengths	In still air	3 to 8 feet beyond end of discharge sleeve				8 to 12 feet beyond end of discharge sleeve			

ACCESSORY OPTIONS

Air filter assemblies and silencers

Air filter assemblies help to trap airborne particulate matter. They are offered with washable replaceable filter elements or with permanent metallic elements.

Filter silencers help reduce noise levels. They physically become a part of the OVENPAK®-II Burner's filter housing and enclose the combustion air inlet (as shown in photograph at right). They must be furnished in conjunction with a filter element assembly described above.

Sound levels from actual tests conducted at full-rated 60 Hz capacity are shown in table at right. Measurements are the average maximum at high fire for standard burner (natural gas, 8" discharge sleeve).

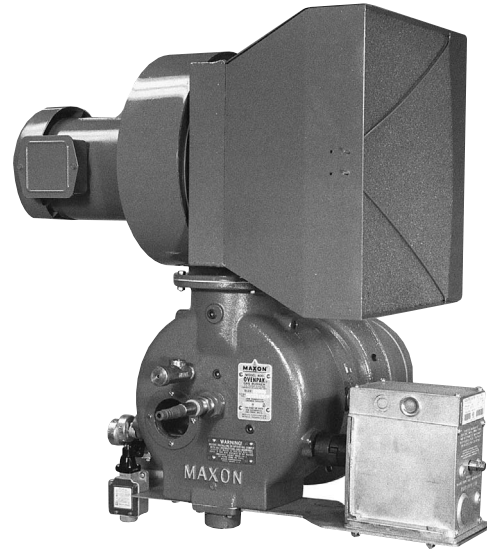

Fig. 6. Model 415 OVENPAK®-II Burner assembly with combustion air filter assembly (including replaceable foam filter element). Permanent metallic filter element may be substituted for standard foam filter element at extra cost.

Burner Size	405	408	415	425	435	445	456	470	487
Sound Level (dBA)	80	83	84	86	86	90	90	93	93

When accessories and/or options are added, use the following guidelines to calculate sound levels.

Filter (permanent)	add 2 dB (3dB)
Silencer (with permanent filter)	subtract 2 db (1 dB)
12" discharge sleeve	add 2 dB
50 Hz motor – 83% capacity	subtract 2 dB
Propane gas	add 4 dB

Combine the adds and subtracts for net change when calculating sound levels with more than one of these options/accessories. (Example: A burner with silencer and operating on propane would be 2 dB louder.)

Silencer includes filter element as standard.

NOTE: Background may affect on-site measurements.

ACCESSORY OPTIONS

Auxiliary Switches

Low Fire (or Set Position) Switch Assembly includes one cam-actuated switch (2 SPST circuits) which can be set to open a circuit when burner leaves minimum (or set) position. It meets NEMA #4/IP665 standards for weatherproof, outdoors, non-hazardous locations.

High and Low Fire Position Switch Assembly includes 2 cam-actuated switches (each with 2 SPST circuits). One switch may be field-set to activate at high fire position, while the other is set to activate at low fire position.

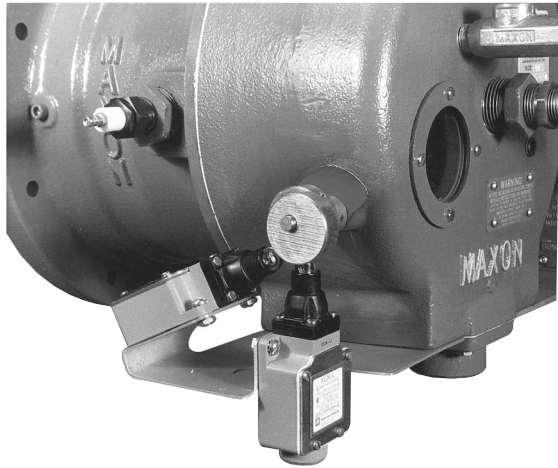

Fig. 7. Optional high and low fire position switch set shown on.

Air Butterfly Position Switch Set provides one switch (2 SPST circuits) to monitor physical movement and/or position of OVENPAK®-II Burner's air butterfly control valve.

Discharge Sleeves are available in 3 versions:

- Standard sleeve is 8" long, made of #310 SS, and is suitable for downstream temperatures up to 1000°F (538°C).
- For higher velocities, specify 12" long sleeve made of #310 SS for downstream temperatures up to 1000°F (538°C).
- For higher downstream temperatures between 1000°F (538°C) and 1500°F (816°C), specify 8" long, or 12" long high-temperature sleeve.

Oven Wall Adapter Plate provides a means of mounting an OVENPAK®-II Burner in place of an older style Model "400" OVENPAK® Burner.

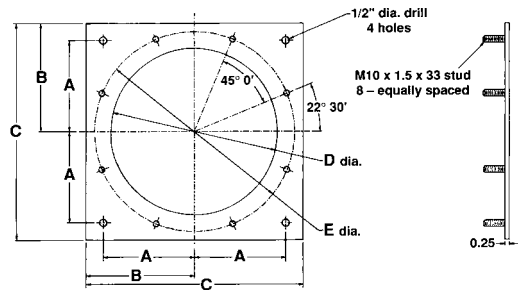

Oven wall adapter plate dimensions (in inches).

Discharge sleeve diameter	6"	8"	10"	12"
A	3.62	4.44	5.62	6.69
B	5.12	6.12	6.69	8.25
C	10.25	12.25	13.38	16.50
D	7.28	9.34	11.25	13.25
E	8.75	10.50	12.31	14.75

OVENPAK®-II BURNER CONFIGURATIONS

MAXON OVENPAK®-II Burner provides additional application flexibility with multiple component arrangements. The standard configuration illustrated in the center of this page may easily be switched to any of these other configurations to accommodate fieldsite space requirements.

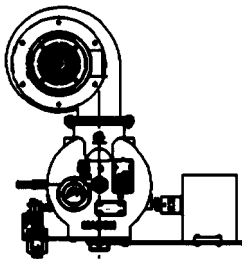
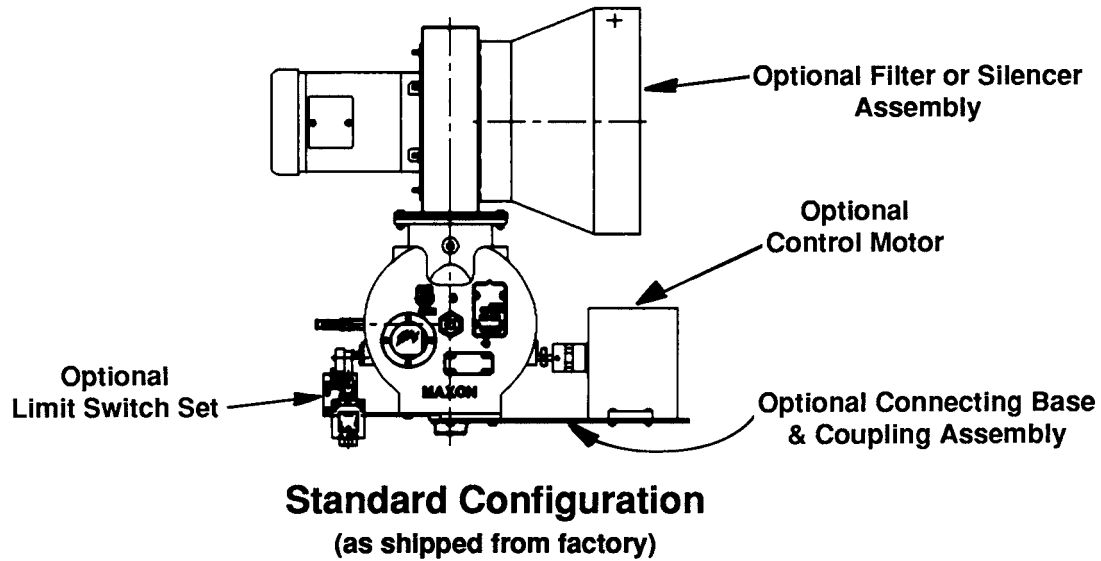

Fig. 8. Blower scroll case to LEFT with control motor on RIGHT.

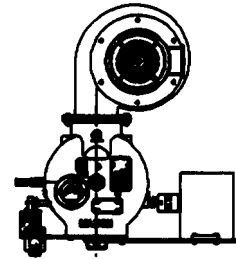

Fig. 10. Blower scroll case to RIGHT with control motor on RIGHT.

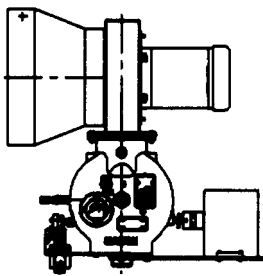

Fig. 9. Combustion air filter housing to LEFT with control motor on RIGHT.

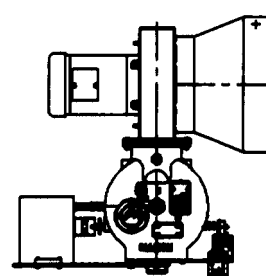
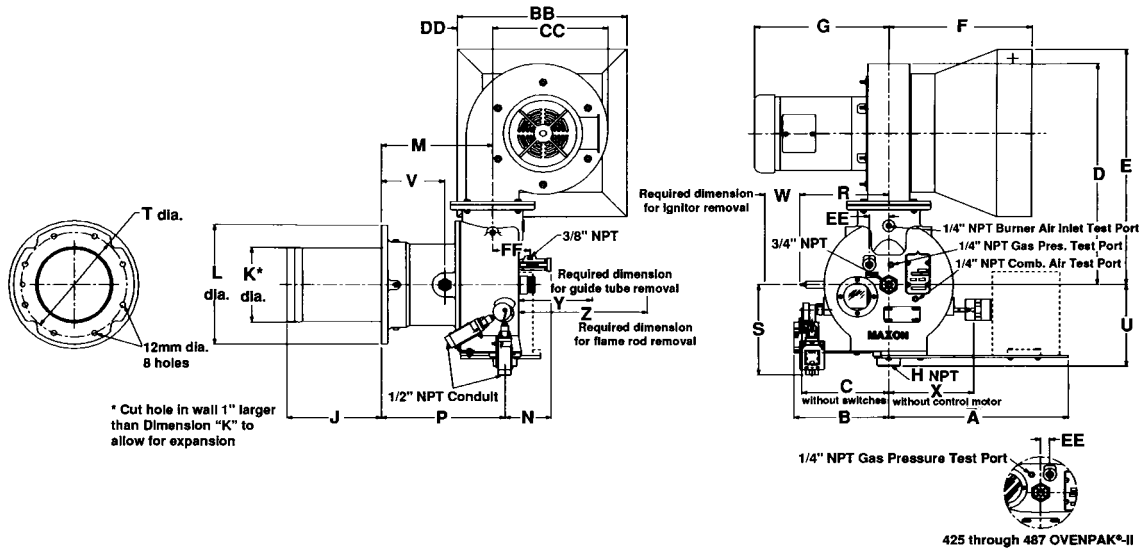

Fig. 11. Combustion air filter housing to RIGHT with control motor on LEFT.

NOTE: Optional switch sets are always on opposite side from mounted control motor.

DIMENSIONS

Model “400” OVENPAK®-II Burners



Burner Model	A	B	C	D	E	F	G	H	J	K	L	M	N	P
405	15.25	7.88	7.25	18.62	19.75	11.75	11.19	1	8.0	6.25	10.0	9.38	4.00	10.38
408								1-1/4		8.31	12.0	9.31		10.31
415								1-1/2		7.85	10.25	13.31		10.94
425	16.25	7.81	7.88	23.3	27.4	17.25	11.44	2	7.62	12.25	16.25	15.56	6.44	16.56
435	15.06	6.69	6.81	26.7	30.0	17.38	14.44							
445				28.9	31.2		15.38							
456	10.56	9.69	14.75	6.38	8.88	3.69	6.81	9.88	23.6	25.1	13.44	5.5	0.75	4.69
470				6.94							17.38	4.31		
487														

Burner Model	R	S	T	U	V	W	X	Y	Z	BB	CC	DD	EE	FF														
405	8.25	8.81	8.75	6.81	5.31	3.12	7.25	5.88	13.06	14.0	8.5	2.81	1.62	3.31														
408			10.5		5.25	3.88																						
415			7.5																									
425	10.56	9.69	14.75	6.38	8.88	3.69	6.81	9.88	23.6	25.1	13.44	5.5	0.75	4.69														
435															8.81	7.81	12.31	7.19	5.31	4.31	7.88	8.31	17.62	23.2	11.31	6.06		
445															10.56	9.69	14.75	6.38	8.88	3.69	6.81	9.88	23.6	25.1	13.44	5.5	0.75	4.69
456																												
470				6.94							17.38	4.31																
487																												

NOTE: All OVENPAK®-II Burners use ISO standard (metric) fasteners.

Pipe threads on this page conform to NPT (ANSI Standard B2.1).

DIMENSIONS

Model "EB" OVENPAK®-II Burner

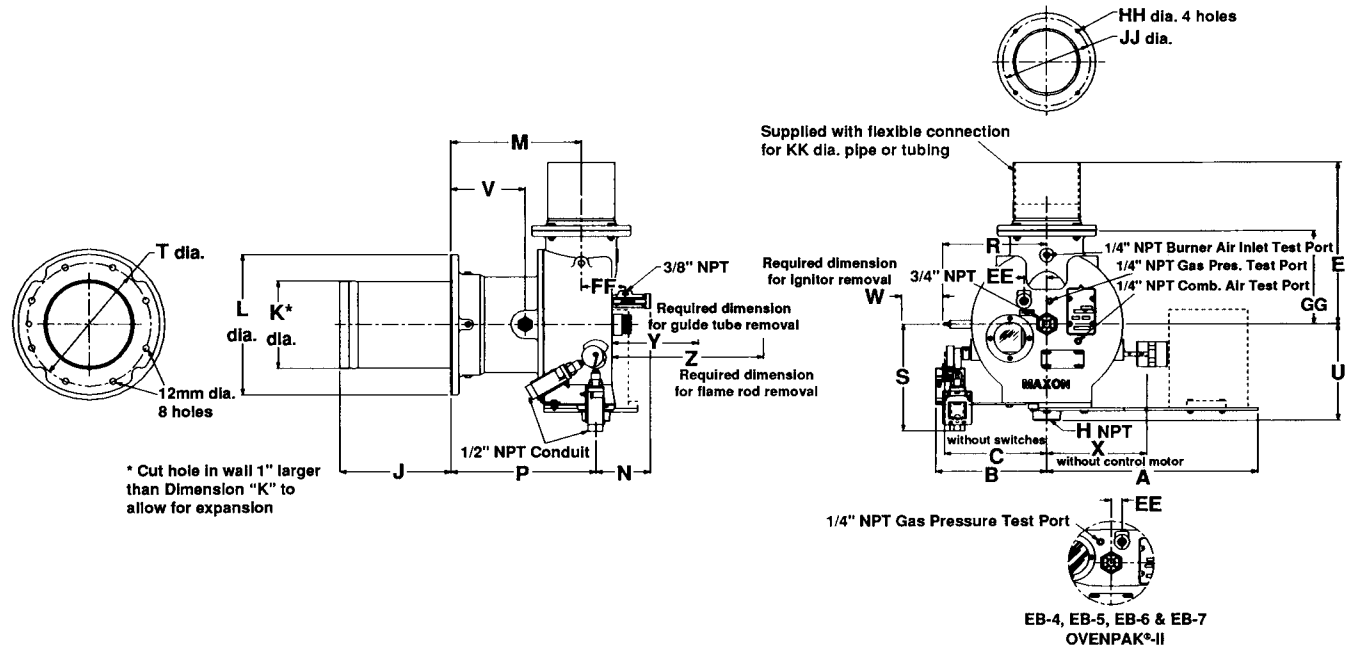

Burner Model	A	B	C	E	H	J	K	L	M	N	P	R	S								
EB-1	15.25	7.88	7.25	11.5	1	8.0	6.25	10.0	9.38	4.06	10.38	8.25	8.81								
EB-2					8.31		12.0	9.31	10.31		7.5										
EB-3					1-1/4		7.85	10.25	13.31		10.94	6.06		11.94	8.81	7.81					
EB-4	16.25	7.81	7.88	15.5	1-1/2	7.85	10.25	13.31	10.94	6.06	11.94	8.81	7.81								
EB-5					2									7.62	12.25	16.25	15.56	6.44	16.56	10.56	9.69
EB-6					3																
EB-7	15.06	6.69	6.81	16.56																	

Burner Model	T	U	V	W	X	Y	Z	EE	FF	GG	HH	JJ	KK			
EB-1	8.75	6.81	5.31	3.12	7.25	5.88	13.06	1.62	3.31	6.69	7mm	6.25	4.5			
EB-2			5.25	3.88												
EB-3			10.5													
EB-4	12.31	7.19	5.31	4.31	7.88	8.31	17.62	0.75	4.31	8.50	12mm	8.25	6.62			
EB-5																
EB-6														6.38	8.88	3.69
EB-7	6.94															

NOTE: All OVENPAK®-II Burners use ISO standard (metric) fasteners.

Pipe threads on this page conform to NPT (ANSI Standard B2.1).

DIMENSIONS

Refractory Lined Discharge Sleeve

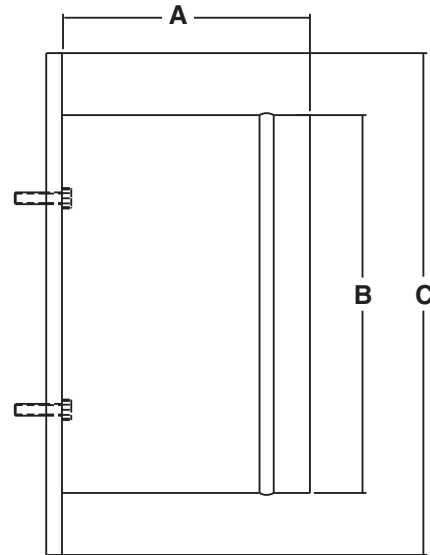
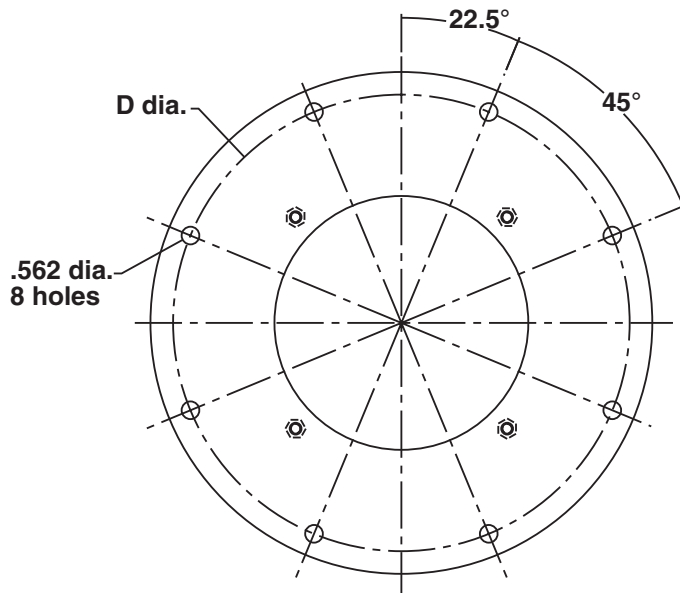

Burner Model	A	B	C	D dia.
405, 408 EB1, EB2	7.88	10.25	14.06	12.63
415 EB-3	7.88	12.12	15.94	14.5
425, 435 EB4, EB5	7.88	14.18	18.0	16.53
445-487 EB6, EB7	7.88	16.18	20.0	18.53

NOTE: Install refractory-lined sleeve to that metal sleeve is fully covered with insulation.

COMPONENT IDENTIFICATION

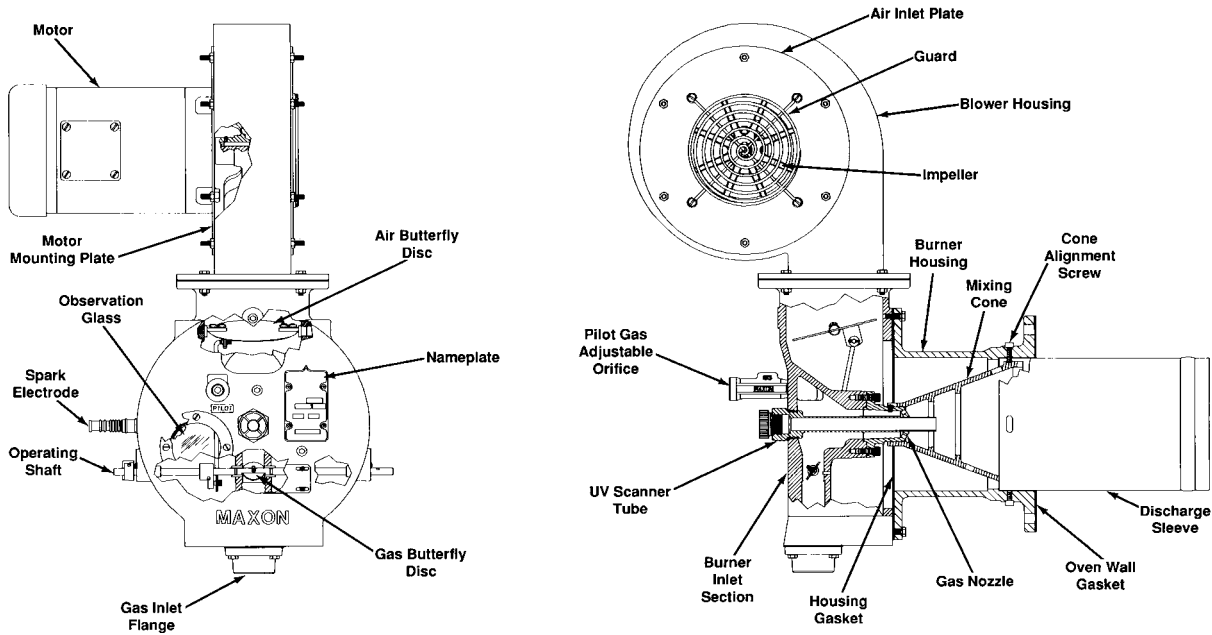

Suggested spare parts

- Spark Ignitor
- Flame Rod, if used
- Motor
- Impeller
- Gas/Air Valve Linkage Kit
- Discharge Sleeve
- Oven Wall Gasket
- Filter Elements, if used
- Mixing Cone

To order parts for an existing OVENPAK®-II Burner assembly, list:

1. Name(s) of part(s) from above illustration
2. Quantity of each required
3. OVENPAK®-II Burner nameplate information:
 - Size of burner
 - Assembly number and date
 - Factory Order number

NAMEPLATE

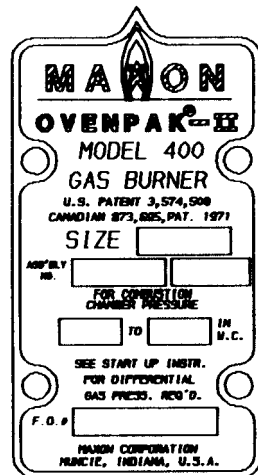

SUGGESTED MAINTENANCE/INSPECTION PROCEDURES

Discharge sleeve and cone alignment

The mixing cone is self-centering within the burner housing and discharge sleeve to provide a small annular opening for the flow of some cooling combustion air along the discharge sleeve wall. We SUGGEST periodic inspection from the discharge side of the burner to assure that this clearance is maintained.

WARNING

Blockage of the annular opening will lessen burner service life.

Filters should be inspected regularly and cleaned, using a vacuum to remove loose/dry accumulations, then washing and/or degreasing as appropriate for the filter type used.

To replace flame rod or spark ignitor:

1. Check Table 1 at right for dimension Y and cut tip to length shown.
2. Insert 1/2" NPT collar into burner and snug into position.
3. Insert insulator through collar into burner.
4. Check table for dimension X, position accordingly, and tighten locking bushing until insulator is held firmly.

WARNING

Over-tightening locking bushing may damage ceramic insulator.

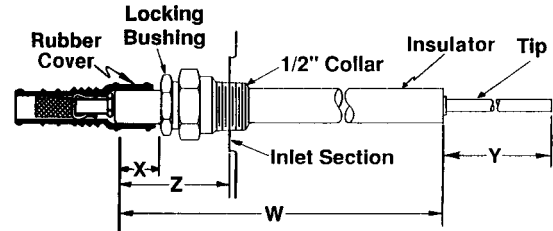

Flame rod and spark ignitor dimensions for all Model "400" OVENPAK®-II Burners.

Burner Model		Spark Ignitor Dimensions (in inches)			Flame Rod Dimensions (in inches)		
		X	Y	W	X	Y	Z
EB-1	405	2	0.4	5.5	0.9	6.0	3.2
EB-2	408						
EB-3	415	1.2					
EB-4	425	1.8		6.5	0.9	10.8	3.2
EB-5	435						
EB-6 EB-7	445	2.4	8.25	1.0	11.75	---	
	456						
	470						
	487						

INSTALLATION INSTRUCTIONS

General Instructions

IMPORTANT

Do not discard packing material until all loose items are accounted for.

To prevent damage in transit, the spark ignitor, discharge sleeve, mounting gaskets, flame rod and connecting linkage components may be packed separately and shipped loose with your new MAXON OVENPAK®-II Burner.

The burner itself is normally only a part of your complete combustion system. Additional pipe train accessories and control components will be required for a complete system installation. The sketch below shows a typical gas train as might be used with OVENPAK®-II gas fired burners.

Piping Layout as sometimes required by insurance and standards groups

Block and Bleed gas train arrangement

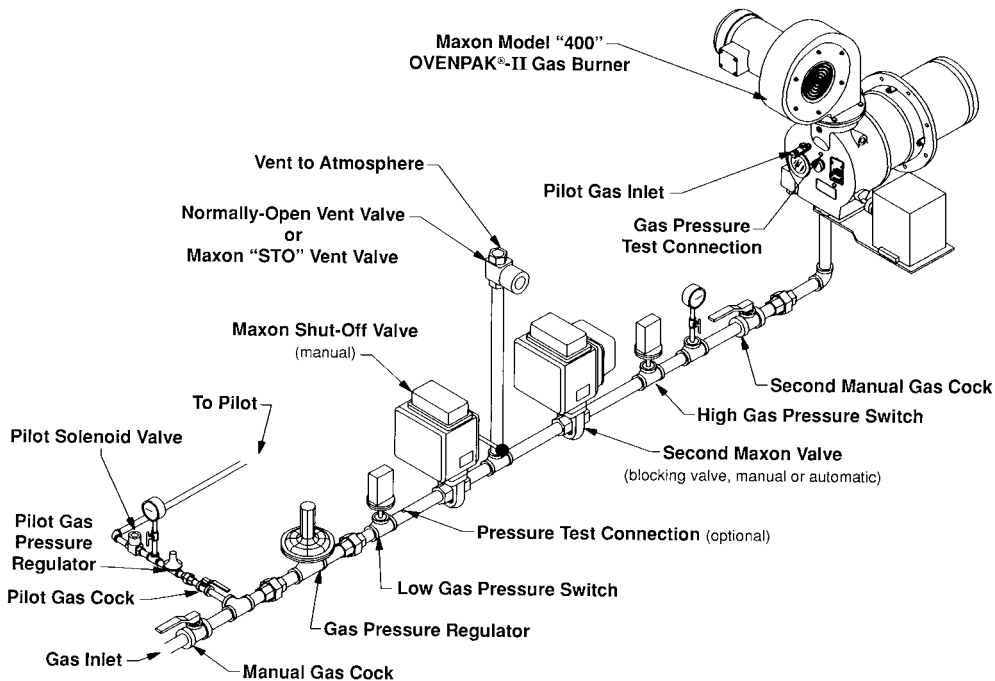

OVENPAK®-II Burners provide the air supply (except for EB versions, which require a separate combustion air blower). They also serve as a fuel flow control and fuel/air mixing device.

Burner should not be exposed to direct radiant heat or positioned where it might draw in inert gases. If such conditions exist, consider filters, relocation and/or use of the EB version and external air supply.

Electrical service must match the voltage, phase and cycle of all electrical system components and be compatible with burner nameplate ratings. Insure that all normal control safeguards are satisfied. Combustion air blower should continue to run after shutdown to allow burner to cool.

Gas supply piping must be large enough to maintain the required fuel pressures cataloged for the particular burner size used with burner operating at full rated capacity.

Anything more than minimal distance or piping turns may necessitate oversizing piping runs to keep pressure drops within acceptable ranges.

Inlet pipe leading to any burner should be at least four pipe diameters in length. If multiple burners are fed from a single gas train, care should be taken to minimize pressure drop and give maximum uniformity.

Clean fuel lines are essential to prevent blockage of pipe train components or burner gas ports.

Main Shut-Off Cock should be upstream of both the main gas regulator and pilot line take-off. Use it to shut off fuel to both pilot and main burner during shutdown periods of more than a few hours.

The fuel throttling valve contained within a MAXON burner is not intended for tight shut-off.

Main gas regulator is essential to maintain a uniform system supply pressure. If one pipe train supplies multiple burners, provide a separate regulator in the branch leading to each burner system.

Size the regulator for full system capacity at the required pressure, carefully considering pipe train losses. Follow the instructions attached to the regulator during installation and be sure to remove any shipping pin or block.

Pilot take-off should be upstream of the main gas regulator, but downstream of the main gas cock. It should normally include its own pilot gas regulator, a solenoid valve and shut-off cock. A pilot adjustable orifice at the pilot inlet simplifies adjustment.

Pilot piping must be large enough to provide for the full flow and pressures shown in the catalog for your particular burner size.

Fuel Shut-Off Valves (when properly connected to a control system) shut the fuel supply off when a hazardous operating condition is sensed. Manual reset valves require operator attendance each time the system is started up (or restarted after a trip-out). Motorized shut-off valves permit automatic start-restart when used with an appropriate control system.

Test connections are essential for burner adjustment. They should be provided immediately downstream of the regulator and are included in the burner itself. **Test connections must be plugged except when readings are being taken.**

Horizontal mounting is preferred, but burner may be mounted in any position suitable for automatic control motor and UV scanner (if used).

OVENPAK®-II Burners will typically be installed through an oven wall or insulated air duct. Cut opening approximately 1" larger in diameter than discharge sleeve to allow for thermal expansion of sleeve.

Burner mounting requires eight studs and a flat mounting surface perfectly centered on the discharge sleeve.

After placing burner in position over studs, add lock washers and nuts, then draw up hand-tight only. Check that burner is seated evenly all around the flange, filling any gaps to prevent air leakage, then tighten all nuts firmly.

For proper performance of any burner, air inlet and motor should be surrounded by clean, fresh, cool air.

Burner and pipe manifold support will be required to support weight of the burner and connected pipe train components. Air control motors, in particular, require additional support. MAXON connecting base and linkage assemblies are designed to position the control motors to work with the burner, not to support their weight.

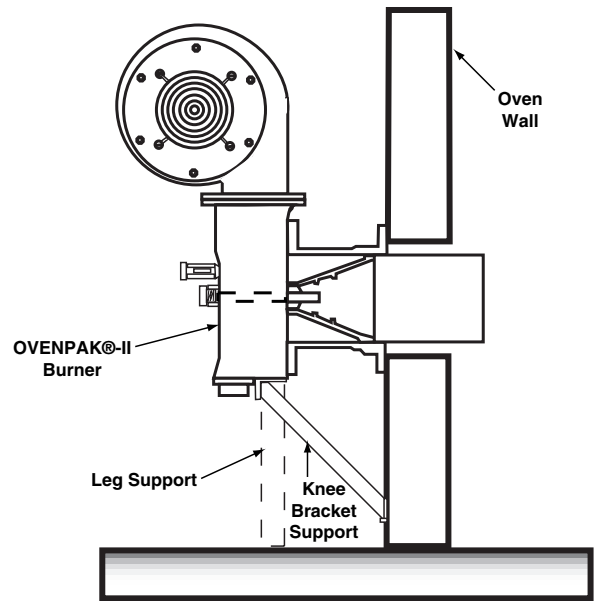
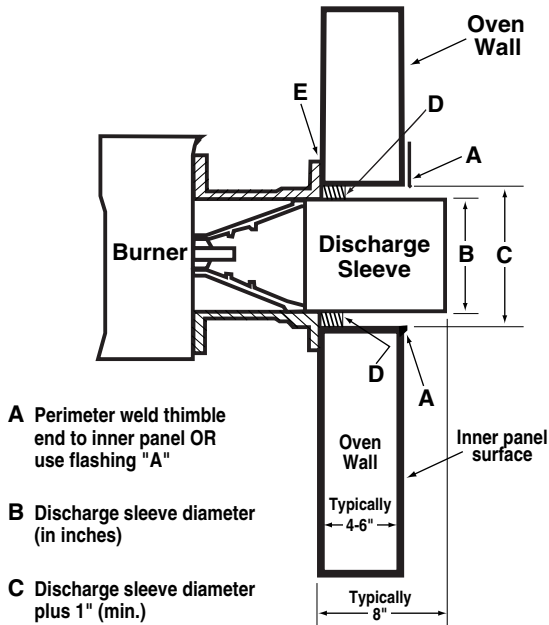

Fig. 12. Suggested supporting arrangements for OVENPAK®-II Burners.

Additional burner support may be required in conjunction with a stiffener plate when mounting OVENPAK®-II Burner (weighing 100-350 pounds) through typical thin wall of heater/oven panels.

For push-through systems, use MAXON oven wall gasket (E) between stiffener plate and burner body flange. Fill area D (see sketch below) with no more than 2" of high temperature packing (too little will overheat mounting; too much will overheat sleeve).



Note: It is important that no insulation or flashing come in contact with the discharge sleeve beyond "D."

Fig. 13. Typical discharge sleeve mounting recommendations.

For pull-through systems, spacers may be installed on stud bolts and area D left empty to admit cooling air past the sleeve.

WARNING

Welding of burner flange to stiffener plate may cause warpage of burner flange and require additional seal material to prevent leakage.

Four lock screws permit centering of mixing cone within burner body and sleeve.

Discharge sleeve and cone alignment

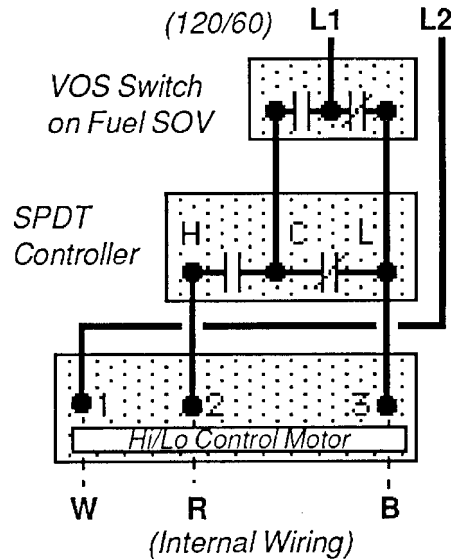

Cone self centering is achieved by using fixed length cone screws. This eliminates the need to adjust for cone alignment. Cone screws should be tight against the housing to ensure proper cone spacing and cone security.



CAUTION

Loose cone screws can cause the following: cone overheating, spark electrode damage, cone ejection.

The mixing cone is centered in the burner housing and discharge sleeve to provide a small annular opening for the flow of cooling air along the discharge sleeve wall. We SUGGEST periodic inspection of cone screws for tightness in the housing and from the discharge side of the burner to insure that annular opening is maintained.

Blockage of the annular opening will lessen burner service life.

Discharge sleeve must be flush with, or extend beyond, interior wall. MAXON can supply a special 12" long discharge sleeve, but higher noise levels may result, particularly when firing on propane.

An external viewing port should be provided for flame observation, preferably in such a position that burner pilot and main flame can both be seen.

Flame sensing can be accomplished by either flame rod or UV scanner. When UV scanner is used, it should be kept as close to burner as feasible. Heat block, if used, may affect signal strength with some brands of scanners.

Field conversion from a flame rod version to a UV scanner version and vice versa is possible without any additional burner parts.

Alternate fuels may require correction of supply pressures.

MAXON assumes no responsibility for the use or misuse of the layouts shown. Specific piping and wiring diagrams should always be submitted to the appropriate agencies for approval on each application.

Multi-burner installations require special considerations if supplied by a common pipe train and/or air supply. **Air and Gas Balancing Valves** should be used for improved heating uniformity; **Gas Swing- Check Valves** should be installed as close as possible to each burner inlet for dependable lightoff (gas manifold may otherwise act as a reservoir, preventing lightoff during trial-for-ignition period).

Control system's circuitry must not allow main Fuel Shut-Off Valve to be opened unless combustion air is on, and must de-energize valve upon loss of combustion air pressure, along with the other usual system interlocks. Motor starter is to be interlocked with valve, whether or not a combustion air pressure switch is used.

Installation of control motor mounting bracket

Model 425, 435, 445, 487, EB-4, EB-5, EB-6 and EB-7 OVENPAK®-II Burners require the control motor mounting bracket to be installed as follows, based on the type of control motor being used.

To mount the bracket, follow the procedure outlined below.

1. Determine which holes to use:
 - All Barber Coleman control motors use the holes stamped with the number 2.
 - All Honeywell Modutrol control motors use the holes stamped with the number 3. Both holes are located on the same side as the operating shaft elliptical hole. Refer to Figure 2 below.
2. Mount the control motor bracket with two M6X20 hex head screws so the chosen holes align with the bolt flanges located above the operating shaft.
3. Attach the stand off spacers between the control motor bracket and the burner with two M6X80 hex head bolts. Mount the bolts through the narrow slots located below holes 2 and 3. Refer to Figures 1 and 2.

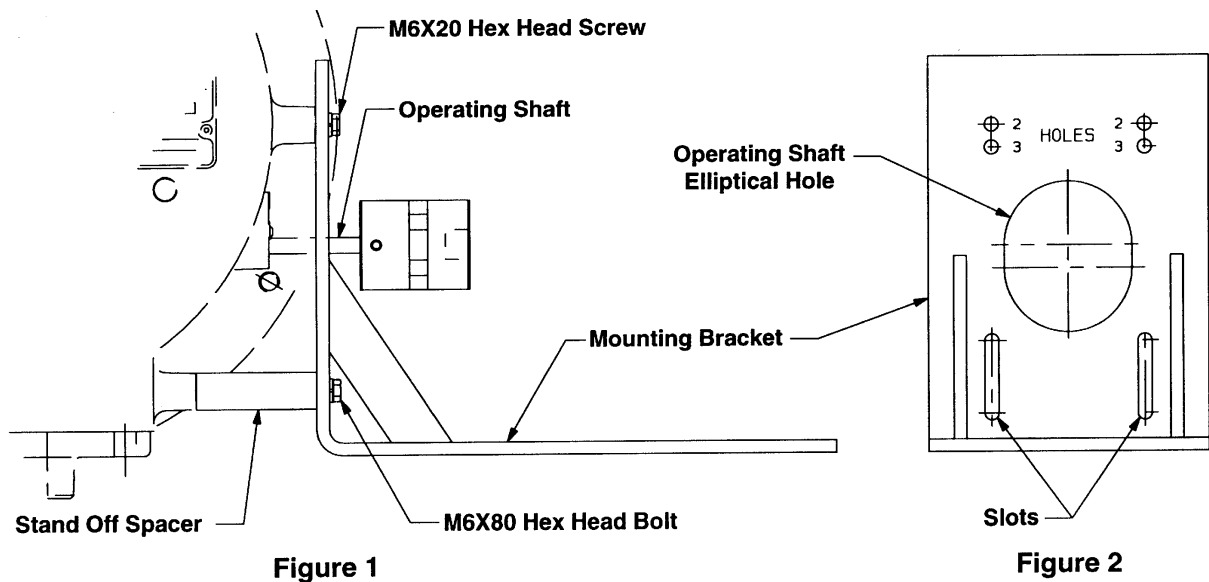

START-UP INSTRUCTIONS

Read complete instructions before proceeding, and familiarize yourself with all the system's equipment components. Verify that your equipment has been installed in accordance with the original manufacturer's current instructions.



CAUTION

Initial adjustment and light-off should be undertaken only by trained and experienced personnel familiar with combustion systems, with control/safety circuitry, and with knowledge of the overall installation.

Instructions provided by the company and/or individuals responsible for the manufacture and/or overall installation of complete system incorporating MAXON burners take precedence over these provided by MAXON. If MAXON instructions conflict with any codes or regulations, contact MAXON Corporation before attempting start-up.

For initial OVENPAK®-II Burner start-up

- 1. Close all burner fuel valves and cocks.** Make preliminary adjustments to fuel gas regulators. Remove pilot and main gas regulator's adjusting screw covers. Turn adjusting screw down (clockwise) to approximately mid-position. Close pilot gas adjustable orifice screw by turning in clockwise until it stops. (Do not over-tighten.) Then back out the adjustable orifice (counter-clockwise) approximately 2-3 turns.
- 2. Check all electric circuitry.** Verify that all control devices and interlocks are operable and functioning within their respective settings/ranges. Be sure all air and gas manifolds are tight and that test ports are plugged if not being used.
- 3. Check that all duct and chamber dampers are properly positioned** and locked into operating positions.
- 4. Disconnect the automatic control motor's coupler** from the OVENPAK® -II Burner's shaft by loosening the set screw and sliding the coupler halves apart and removing the rubber coupler. Make sure that the coupler fingers will rotate without hitting.

For Model EB-MRV Burners, the connecting linkage on the separate control valve must be similarly loosened and disconnected. Refer to specific adjusting procedures relating to control valve adjustment in MAXON catalog.

Initial start-up adjustment should only be accomplished during a manual burner control mode.

- 5. Start all system-related fans and blowers.** Check for proper motor rotation and impeller direction. Verify that all control interlocks are working. Allow air handling equipment to run for adequate purge of your manifolds and combustion chamber plenums. With main gas shut off, manually advance burner to high fire position so that air only flows through burner and combustion chamber.



CAUTION

Do not by-pass control panel timers typically controlling sequential operations.

For EB OVENPAK®-II Burners only (step 6)

- 6. Verify differential air pressure.** With combustion air blower on, all volume air fans operating, and burner at high fire position, connect a manometer between the air test connection on backplate of OVENPAK® -II Burner and your combustion chamber static pressure test connection. This will give a direct differential air pressure reading.

Determine your differential air pressure reading by taking an additional reading with manometer connected between the burner's air pressure test port and atmosphere with the burner at high fire position, fuel valves closed, and all air handling systems running. Subtract the combustion chamber static pressure obtained above from this air pressure reading to give you differential air pressure reading. The differential air pressure setting determines the burner's capacity and performance capabilities.

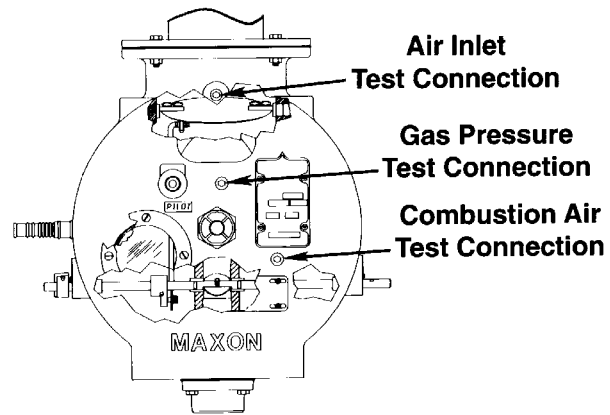

- 7. Determine the required differential gas pressure** using this differential air pressure reading obtained from step 6. If your combustion chamber does not have a static pressure test connection, then you must measure combustion chamber static pressure by connecting a manometer between the gas pressure test port on the burner's backplate and to atmosphere with the burner at low fire position, fuel valves closed, and all air handling systems running. High fire pressures are provided in MAXON product line catalog literature and/or read data stamped into burner nameplate.
- 8. Verify that spark ignitor is properly positioned** and lines up with the appropriate dimensions required for your specific burner. (Refer to appropriate MAXON catalog specification table.) Check that spark ignitor arcs at the end of your properly positioned ignitor.
- 9. Return burner control valve (or crank) to low fire position** when purge of system is complete.
- 10. Open main and pilot gas cocks,** then attempt spark ignition to light pilot while slowly turning pilot gas regulator spring clockwise and/or adjustable orifice screw counter-clockwise to increase fuel flow. Repeat procedure as necessary until pilot ignites as air might have to

be bled out of fuel supply lines before reliable pilot flame is established. Pilot gas regulator should normally be set for as low a pressure as possible, using fuller opening of pilot gas adjustable orifice (if used).

11. **After ignition, adjust pilot flame** for good stable flame shape. A rule of thumb is that any pilot over a tennis ball size is probably too large. This assumes you have visual access to the pilot flame. If this is not possible, then adjust pilot to give the strongest and most stable flame signal through your flame safety circuit. This signal strength can be read with a micro-amp meter. The signal strength (or range) will be determined by the specific type of flame safeguard instrument you have with your burner system.
12. **Re-check pilot ignition** by closing pilot gas cock or otherwise causing pilot outage. Re-light and refine pilot gas adjustment as necessary to get ignition within a second or two. The flame safeguard relays should now power your main fuel Shut-Off Valve(s).



CAUTION

After completing steps above, recheck all interlocking safety components and circuitry to prove that they are properly installed, correctly set, and fully operational.

If in doubt, shut the system down, close pilot cock and contact responsible individual before proceeding further.

13. **Establish main flame.** With burner at low fire position, back out main gas pressure regulator adjusting screw (counter-clockwise) to get lowest outlet pressure possible. Open all manual fuel shut-off valves (automatic fuel shut-off valve should already be open) so gas flows to burner inlet. There should be little, if any, change in flame appearance. Turn main regulator adjusting screw in (clockwise) to obtain outlet pressure of about 4"-6" wc higher than combustion chamber pressure (2"-4" wc for propane, considerably higher for some EB versions). Main flame should now appear larger than pilot-only flame.
14. **Establish high fire setting** by slowly moving burner toward high fire position while observing gas pressure at burner gas test connection. Refine main gas regulator adjustment as necessary to provide correct differential pressure (gauge to combustion chamber, see step 7) at high fire. If pressure cannot be adjusted low enough, a different regulator or regulator spring may be necessary, or a limiting orifice valve (such as MAXON's Series "BV") should be added. Do not, however, exceed 4" wc pressure drop between regulator outlet and burner inlet.



CAUTION

If burner(s) go out, close shut-off valve or shut main gas cock at once.

Return to minimum setting, re-light pilots if necessary, then turn main gas on again. Check carefully that every burner is lit before proceeding.

Cycle burner from minimum to maximum and refine adjustment, if necessary.

For operation with interrupted pilot (as recommended), shut off pilots and cycle burner from minimum to maximum and back several times to verify the flame is maintained.

15. **When burner performance is satisfactory** and stable throughout the firing range, reconnect control motor. **With interrupted pilot**, it may be necessary to set control for somewhat higher than minimum burner setting to permit hold-in of flame detection system without pilot.



CAUTION

Internal drive mechanism within the control motor may be damaged if linkage is adjusted so as to cause binding with burner in high or low fire position.

16. **Re-check differential gas pressure** with unit at operating temperature. Refine high fire setting if necessary, considering differential pressure, flame length, and appearance. Natural gas flame should normally be predominantly clear blue but possibly with semi-luminous tips. Dust or contaminants in the air stream may affect flame appearance.

START-UP INSTRUCTIONS

17. **Plug all test connections not in use to avoid dangerous fuel leakage.** Replace equipment cover caps and tighten linkage screws.
18. **Check out overall system operation** by cycling through light-off at minimum, interrupting pilot, and allowing temperature control system to cycle burner from minimum to maximum and return. Recheck all safety system interlocks for proper setting and operation.

NOTE: Typical gas firing control sequence for MAXON burners is provided only as a guide. Instructions provided by complete system manufacturer incorporating MAXON burners take precedence.

For gas firing OVENPAK®-II Burner

Light-off:

- a. Close cocks, shut-off valve(s)
- b. Verify burner at low fire
- c. Start recirculating/exhaust fans
- d. Start burner blower
- e. Purge at least 4 air changes
- f. Open pilot & main gas cocks

Shut-down:

- a. Close main & pilot gas cocks
- b. Keep combustion air blower running after shut-down long enough to allow burner to cool



WARNING

Test every UV installation for dangerous spark excitation from ignitors and other possible sources of direct or reflected UV radiation. Use only gas-tight scanner connections.

19. Before system is placed into full service, instruct operator personnel on proper start-up operation with shut-down of system, establishing written instructions for their future reference.

Distributed by:



888.858.3647 | relevantsolutions.com

MAXON

201 East 18th Street
P.O. Box 2068
Muncie, IN 47307-0068
www.maxoncorp.com

Maxon reserves the right to alter specifications and data without prior notice.

Automation and Control Solutions

Honeywell International Inc.
1985 Douglas Drive North
Golden Valley, MN 55422
customer.honeywell.com

® U.S. Registered Trademark
© 2016 Honeywell International Inc.
32M-01003-02 M.S. Rev. 06-16
Printed in United States

