

# INDITHERM®

## Low temperature gas burners



- **High turndown** for maximum operation flexibility.
- Maximum capacities up to 6 MBtu/h.
- Designed for firing in **indirect fired** processes.
- **Excellent combustion** throughout entire capacity range.
- Maximum application **flexibility** with 8 available burner sizes.
- Packaged design for quick and **easy installation**.
- Alternate refractory block materials for **high temperature** applications.

Distributed by:



888.858.3647 | [relevantsolutions.com](http://relevantsolutions.com)

W W W . M A X O N C O R P . C O M

COMBUSTION SYSTEMS FOR INDUSTRY

MAXON reserves the right to alter specifications and data without prior notice.  
© 2008 Copyright Maxon Corporation. All rights reserved.

  
**MAXON**  
A Honeywell Company

## Product description

The INDITHERM® burner is a nozzle-mix burner, suitable for firing natural gas in many industrial indirect-fired applications where clean combustion and a high turndown are required. They offer a simple and versatile answer to a wide variety of applications.

The INDITHERM® burner incorporates a gas and air valve linked together to control the gas/air ratio over the full operating range. The linkage between gas and air valve is internal in the burner and is factory adjusted. No fine tuning or adjustments in the field are required.

To control the capacity, a low torque control motor can be attached directly onto the burner. The burner can accept most commonly used brands and types of control motors.

The required combustion air is provided by an integrated combustion air blower. This blower is mounted directly onto the burner's housing, thus ensuring a good combustion air distribution inside the burner at all times.

The gas enters the burner through the burner gas inlet connection. It flows through the nozzle and then along the inside of the burner mixing cone where combustion air is progressively and tangentially mixed with the gas. This results in a very wide range of turndown and a highly stable flame under a variety of operating conditions.

The burner has an integrated pilot burner with its own flow adjusting orifice. If required the INDITHERM® can be direct ignited without the use of a pilot.

Provision is made for a single UV scanner to monitor both gas pilot and main flame.

- 1) Burner body
- 2) Burner discharge sleeve
- 3) Combustion air blower
- 4) Spark ignitor
- 5) Flame detector (optional)
- 6) Control motor (optional)
- 7) Connecting bracket and linkage (optional)
- 8) Pilot gas adjusting needle valve (optional)
- 9) High voltage ignition transformer (optional)
- 10) Combustion air pressure connection (Rc1/4")
- 11) Gas inlet

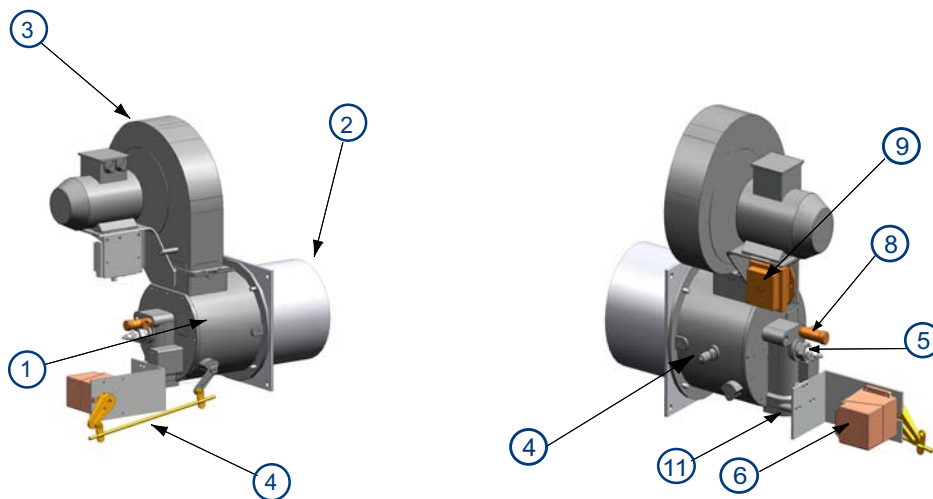

## Available INDITHERM® sizes

Typical burner data										
Fuel: natural gas at 60°F with 1000 Btu ft <sup>3</sup> (st) HHV- sg = 0.6 [1]										
Combustion air: 60°F - 21% O <sub>2</sub> - 50% humidity - sg = 1.0 [1]										
Stated pressures are indicative. Actual pressures are a function of air humidity, altitude, type of fuel, and gas quality.										
Burner size & type		100	200	300	550	700	850	1100	1500	1800
Max. capacity [2]	MBtu/h	0.43	0.80	1.16	1.88	2.6	2.90	3.58	5.02	6.14
Min. capacity	KBtu/h	22.2	18.8	15.4	34	58	51	154	85	85
Gas pressure [3]	"w.c.	1.2	1.8	3.0	2.3	3.4	4.8	7.1	2.1	3.8
Flame length [4]	ft	3.3	4	4	6.5	7	6.5	7.5	8.5	10-13

[1] sg (specific gravity) = relative density to air (density air = 0.0763 lb/ft<sup>3</sup> (st)) Maximum capacity at 3% O<sub>2</sub> firing, no back pressure in combustion chamber. When firing into a tube under slight over pressure, maximum capacity will be reduced. See "Specifications of INDITHERM® burners" for more information.

[2] Gas pressures for natural gas at burner inlet. The stated pressures should be available at burner inlet throughout the entire capacity range. See "Specifications of INDITHERM® burners" for more information.

[3] Flame lengths are derived from measured lab data. Actual flame lengths can differ slightly.

Every INDITHERM® is available in an ISO and NPT version.



**The burner is designed to operate at a 230/400V - 50Hz supply voltage. The burner is designed and factory adjusted to operate at 50Hz. When only 60Hz is available, please contact MAXON.**

## Applications

Because of its versatility, the INDITHERM® can cover numerous types of applications. All types of indirect-fired applications can be equipped with this simple, industrial burner. Among the major applications there are automotive paint-bake ovens and surface treatment, bakery ovens and dryers for the food industry.

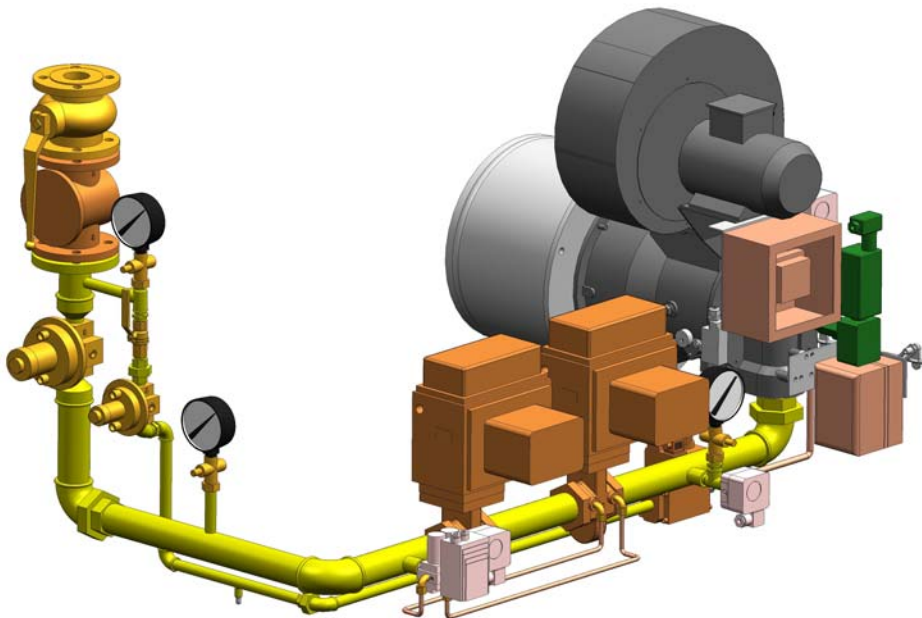

*INDITHERM® 1100 gas burner with natural gas pipe train, including MAXON 5000 shut off valves. System used on paint dry ovens in automotive industry.*

## Dimensions and weights

### INDITHERM® - all sizes

1) Gas inlet

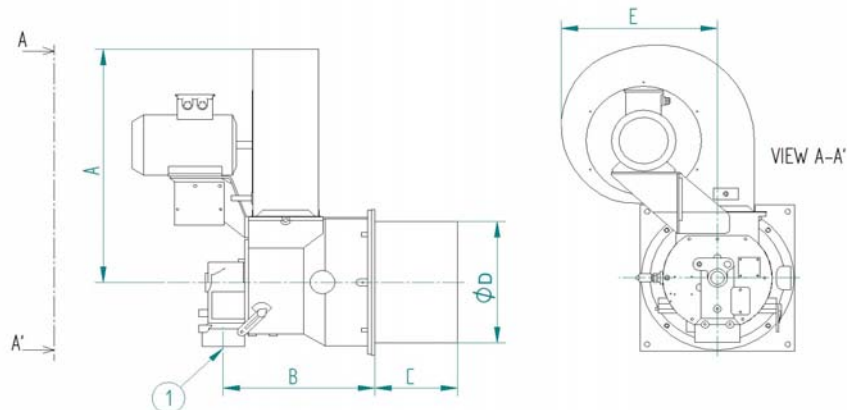

200	1"	365	225	200	160	224	30
Dimensions in inches unless stated otherwise							
Burner size	Gas inlet [1]	A	B [2]	C	ØD [2]	E	Weight (lb) [3]
100	1"	14.37	8.86	7.87	6.30	8.82	66
200	1"	14.37	8.86	7.87	6.30	8.82	66
300	1 1/4"	14.37	8.82	7.87	8.27	8.82	75
550	1 1/2"	20.24	10.04	7.87	10.24	12.13	110
700	2"	23.54	10.04	7.87	10.24	15.24	110
850	2"	23.54	10.04	7.87	10.24	15.24	110
1100	2"	23.50	14.37	7.87	12.24	15.24	156
1500	2"	23.50	14.37	7.87	12.24	15.24	156
1800	3"	25.94	14.37	7.87	12.24	17.76	156

[1] Gas connections are threaded (NPT or ISO)

[2] These dimensions only apply when a standard discharge sleeve is used. Refer to "Specifications of INDITHERM® burners" in case refractory sleeve will be used and for more detailed dimensions.

[3] The weight applies for burners with standard discharge sleeve. Burners with high temperature refractory sleeve will have significantly higher weights. Refer to "Specifications of INDITHERM® burners".