

## Specifications of KINEDIZER® burners

Typical burner data								
Fuel : natural gas at 60° F with 1000's Btu/ft <sup>3</sup> (st) (HHV) - sg = 0.6 [1]								
Combustion air : 60° F - 21 % O <sub>2</sub> - 50 % Humidity - sg = 1.0 [1]								
Stated pressures are indicative. Actual pressures are a function of air humidity, altitude, type of fuel and gas quality								
KINEDIZER® size		0.5M	2.5M	5M	9M	18M	27M	40M
Max. capacity @ n=1.3 (low NO <sub>x</sub> ) [2]	MBtu/h	0.5	2.5	5	9	18	27	40
Max. capacity @ n=1.1	MBtu/h	0.58	3	6	10.5	21.5	32	47
Min. capacity	Btu/s	14	47	36	64	128	194	356
Turndown @ n=1.3 [2]		1:10	1:15	1:40	1:40	1:40	1:40	1:30
Turndown @ n=1.1		1:11	1:17	1:45	1:45	1:45	1:45	1:37
Air flow at max. capacity	scfm	107	540	1071	1960	3920	5845	8658
Air flow at min. capacity	scfm	18	57	66	120	167	248	598
Air turndown		1:6	1:9	1:16	1:16	1:23	1:23	1:14
Advised pilot capacity [3]	BTU/s	28	95	47	95	142	285	711
Absolute min. pilot capacity [4]	BTU/s	22	69	28	48	69	138	417
Pilot gas pressure [5]	"wc	<0.4	1.0	<0.4	0.6	1.0	4.0	8.0
Advised pilot gas piping diameter [6]		1/2"	3/4"	3/4"	3/4"	1"	1-1/2"	2"
Combustion air pressure @ inlet [7]	"wc	35	35	35	35	35	35	28
Combustion air pressure diff. [8]	"wc	28	28	28	28	28	28	20
Natural gas inlet pressure diff. [9]	"wc	47	61	86	83	110	110	67
Flame length @ n=1.3 [2]	ft [10]	0.98	1.47	1.96	3.93	5.90	8.85	13.12
Flame diameter @ n=1.3 [2]	ft [10]	0.49	0.65	0.82	1.47	2.95	3.93	4.92
Flame length @ n=1.1	ft [10]	1.6	2.46	3.28	6.56	9.84	14.76	22.96
Flame diameter @ n=1.1	ft [10]	0.49	0.65	0.82	1.47	2.95	3.93	4.92

[1] sg (specific gravity) = relative density to air (density air = 0.0763 lb/ft<sup>3</sup>(st)).

[2] n = 1.3 meaning 30 % excess air.

[3] Most installations will require a stronger pilot (advised pilot capacity will be required – see [3]).

[4] Absolute minimum pilot capacity is only valid for those supplies that can be started at min. stated combustion air flow, with "long block" and no flow around the flame.

[5] Natural gas pressure at pilot burner gas inlet (absolute minimum pilot capacity).

[6] For information only – strong pilots require adapted piping.

[7] Combustion air pressure required at full capacity at burner inlet, relative to process - add 5 % safety margin + piping & control valve pressure drops for blower sizing.

[8] Differential combustion air pressure at full capacity, between inlet test connection (downstream of the swirler) and process.

[9] Differential natural gas pressure required at burner gas inlet (gas inlet test connection) relative to process, for the "n=1.3" maximum capacities.

[10] All dimensions in ft, for burner firing at max. listed capacity

Distributed by:



888.858.3647 | relevantsolutions.com

## Materials of construction

Burner parts (away from the furnace)	Carbon steel, painted	[1]
Burner parts (in contact with furnace)	AISI 304 (1.4301)	
Flame tip (in contact with the flame)	AISI 310 (1.4541)	
Burner block sleeve (optional)	AISI 304 (1.4301)	
Burner block	Castable refractory	[2]

[1] Optional available: 100 % stainless steel burner

[2] Typical composition of castable refractory : refractory with 50% SiO<sub>2</sub> 45 % Al<sub>2</sub>O<sub>3</sub> and smaller fractions of iron oxide, titanium, lime, ... reinforced with needles (AISI304-1.4301)

## Selection criteria

### KINEDIZER® burner versions

---

To suit the local demands of industry and specific regulations worldwide, the standard KINEDIZER® burner is available in 3 different versions.

All burners can be ordered with NPT gas connection and SCH 10/40 air pipe connection (ANSI version - see drawings on page 3-11.6-13 and page 3-11.6-14). An optional air inlet flange can be provided acc. to ANSI 150 lbs (ANSI version with air flange - see drawing on page 3-11.6-14).

KINEDIZER® 9M through 40M are also available with flanged gas connection (ISO 7005) and air flanges (ISO version - see drawing on page 3-11.6-15). Refer to the drawings or contact MAXON for more details.

On request, special versions, versions for hazardous locations or high back-pressure may be supplied. Contact MAXON for more details.

### Application details

---

KINEDIZER® burners can be used in all direct fired air heating applications, as well low as high temperature. It combines flexibility and stability with high turndown and the lowest available NO<sub>x</sub>-emissions. It can be used in all air heating applications that require low NO<sub>x</sub> firing and allow excess combustion air (typically 30 %) to the burner. The use of KINEDIZER® burners in indirect applications requires special consideration.

Contact MAXON for application details.

### Maximum capacities

---

All KINEDIZER® burners can be fired at higher maximum capacities if sufficient combustion air and fuel gas is allowed to the burner – max. capacities of all sizes can be 20 % higher (40M can be fired up to 40 % higher capacity) if combustion air is available at 60 "wc.

### Preheated air/reduced O<sub>2</sub> air

---

KINEDIZER® burners accept preheated combustion air up to 660° F (800° F on request). Maximum capacities shall be reduced. Preheated combustion air can have reduced O<sub>2</sub> (as low as 17 % if combustion air temperature is 800° F). Mixing of some low O<sub>2</sub> flue gas allows to combine increased system thermal efficiency with best emissions.

### Process back pressure

---

Standard KINEDIZER® burners can accept static back pressures between -40 "wc and 40 "wc. The burner shall be connected to a fuel gas and combustion air control system that is capable of controlling a correct fuel gas ratio against all possible installation back pressures. Special versions are available to accept up to 1 bar(g) back pressure (with PED-certification).

### Process temperature

---

The construction of the burner allows operation in all applications with process temperatures from ambient up to 2000° F. Protect burner from high furnace temperatures during burner stop (purge to avoid back flow of hot furnace/process air).

### Piloting & ignition

---

Direct ignition of standard KINEDIZER® burners is not possible. All KINEDIZER® burners are equipped with a "raw gas" pilot to ignite the main flame (using main burner comb. air). Pilots shall be used only for ignition of the main flame ("interrupted"). Permanent pilot operation is not advised (no "permanent" or "intermittent" pilot) - use main burner at minimum capacity for continuous operation.

Use minimally 5000 V/200 VA ignition transformers for sparking of the spark igniter. Optional ignition equipment for hazardous locations is available as well as high energy igniters for direct ignition.

## Typical ignition sequence

---

- Pre-purge of burner and installation, according to the applicable codes and the installation's requirements.
- Combustion air control valve shall be in the minimum position to allow minimum combustion air flow to the burner.
- Pre-ignition (typically 2 s sparking in air).
- Open pilot gas and continue to spark the ignitor (typically 5 s).
- Stop sparking, continue to power the pilot gas valves and start flame check. Trip burner if no flame from here on.
- Check pilot flame stability (typical 5 s to prove stable pilot)
- Open main gas valves and allow enough time to have main gas in the burner (typical 5 s + time required to have main gas in the burner).
- Close the pilot gas valves.
- Release to modulation (allow modulation of the burner).

Above sequence shall be completed to include all required safety checks during the start-up of the burner (process & burner safeties).

Locate one pilot gas valve as close as possible to the pilot burner gas inlet, to have fast ignition of the pilot burner.

## Ratio control

---

KINEDIZER® burners can be fired stable with air factors ("n") :  $1.05 < n < 1.60$  (5% to 60% excess air) from 20% to 100% of listed maximum air flows (lower capacities require somewhat higher excess air). Flame dimensions and burner emissions are heavily affected by the excess air amount.

## Ratio control on reduced capacity

---

Most KINEDIZER® applications will require burner operation with 30% excess air to have low NO<sub>x</sub>.

On reduced capacities, the excess air will slowly increase.

KINEDIZER® burners will operate with low NO<sub>x</sub> between 20% & 100% of their listed maximum capacity ( $n = 1.3$ ). Below 20% firing rate, the air factor will slightly increase to have the listed air flow at minimum capacity. Changes of combustion air temperature, system back pressure and other parameters could influence gas/air ratio if the control system is not designed to compensate for these.

## Flame supervision

---

KINEDIZER® flames shall be supervised by UV-scanners. Two scanner positions are available. Both locations allow verification of both pilot flame and main flame (it is not possible to distinguish main and pilot flame).

Scanners are mounted on the burner flange and look through the block (30° relative to the burner center line).

Pay attention to possible pick-up of strange flames (if any in the furnace). Allow some purge or cooling air to the scanner connections (typically 1.5 scfm of fresh clean air).

## Flame development

---

KINEDIZER® burners shall be installed in combustion chambers or furnaces that allow full development of the burner flame.

Cylindrical combustion chambers or flame protection sleeves shall have diameters of 1.5 to 2 x burner flame diameter (see table on page 3-11.6-8).

Consult MAXON for proper combustion chamber lay-out.

## Cross velocities

---

Cross velocities up to 3000 ft/min can be allowed over the KINEDIZER® flame. Contact MAXON for proper lay-out and correct emission information in case of cross velocity over the flame.

## Combustion air control & piping

---

KINEDIZER® burners require combustion air control valves with high turn-down (to guarantee correct air flow at minimum capacity). Air control valves shall be properly sized – typically, the air control valve diameter shall be smaller than the burner air inlet. Combustion air piping to the burner shall be done in such way that the air flow to the burner will not disturb the flame.

Location of air control valves directly on the burner inlet is not possible.

- 1) Air flow
- 2) Sight glass

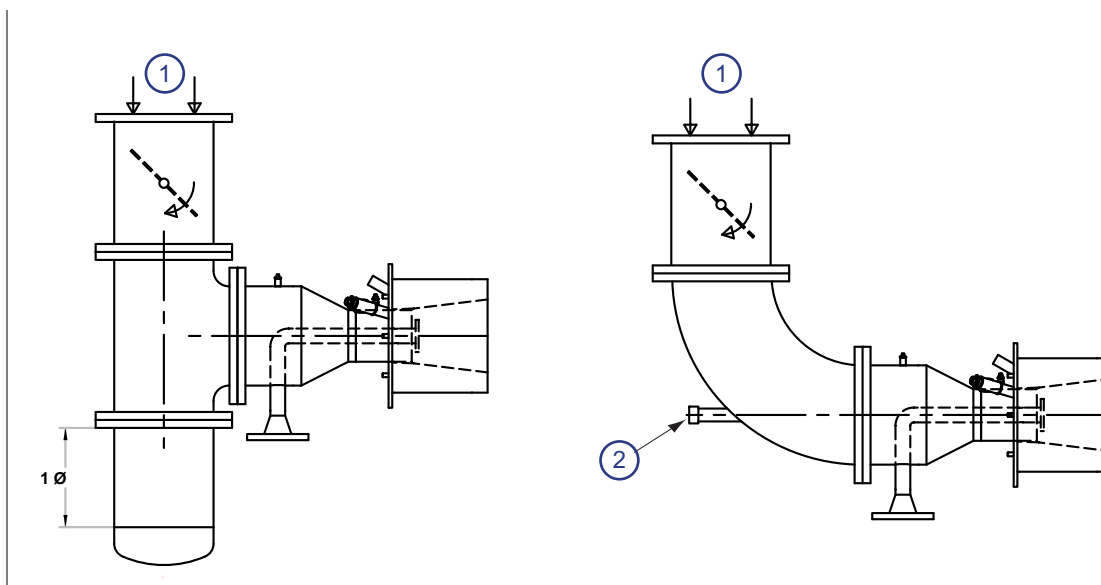

Typical lay-outs with correct piping between air control valve on the KINEDIZER® burner.

### Fuels

Standard KINEDIZER® burners are designed for low NO<sub>x</sub> firing of natural gas only. Special versions are available to fire propane/LPG. Multifuel burners will have higher NO<sub>x</sub> on the alternative fuel.

### Expected emissions

Typical NO<sub>x</sub> for KINEDIZER® burners firing natural gas with 30% excess air:

- cold furnaces (< 1382° F): 30% of a conventional burner
- furnaces up to 1742° F: 40% of a conventional burner

CO highly depends on the installation's lay-out and can be reduced if sufficient dwell time after the flame is allowed. Consult MAXON for correct application information.

### Low NO<sub>x</sub> furnace requirements

Low NO<sub>x</sub> operation requires properly designed combustion chamber or furnace.

KINEDIZER® flames have medium velocity and will be influenced by the atmosphere around the flame. Contact MAXON for proper design.

### CO & low NO<sub>x</sub> Operation

Low NO<sub>x</sub> in combination with low CO is possible if sufficient dwell time is available after the flame. Too fast mixing with cold process air will increase CO.

### Burner blocks

Standard KINEDIZER® burners will be shipped with "long block" as shown on page 3-11.6-13. Two long block options are available: standard (without supporting sleeve) and with supporting sleeve.

Standard blocks without supporting sleeves shall be used only if the blocks are supported by the furnace walls. Supporting sleeves shall be used in all installations where the blocks are not supported (soft walls or steel ducting). Protect the supporting sleeve with insulation if used on high temperature furnaces. Consult Installations instructions for detailed information. For specific applications, burners can be shipped with special block (short block, heat shield or wide block).

Consult MAXON for detailed information.

## Dimensions

### 0.5M and 2.5M KINEDIZER® burners - ANSI

- 1) Main gas inlet
- 2) Pilot gas inlet
- 3) 1/2" NPT scanner connection
- 4) 1/4" NPT purge air connection
- 5) Spark ignitor
- 6) 1/4" NPT gas test connection
- 7) 1/4" NPT air test connection
- 8) 1/4" NPT optional purge air connection
- 9) Optional air inlet flange
- 10) Observation port / alt. scanner position

Conforms to 150# ANSI Fig. Pattern. Bolt holes to straddle burner vertical & horizontal centerline.

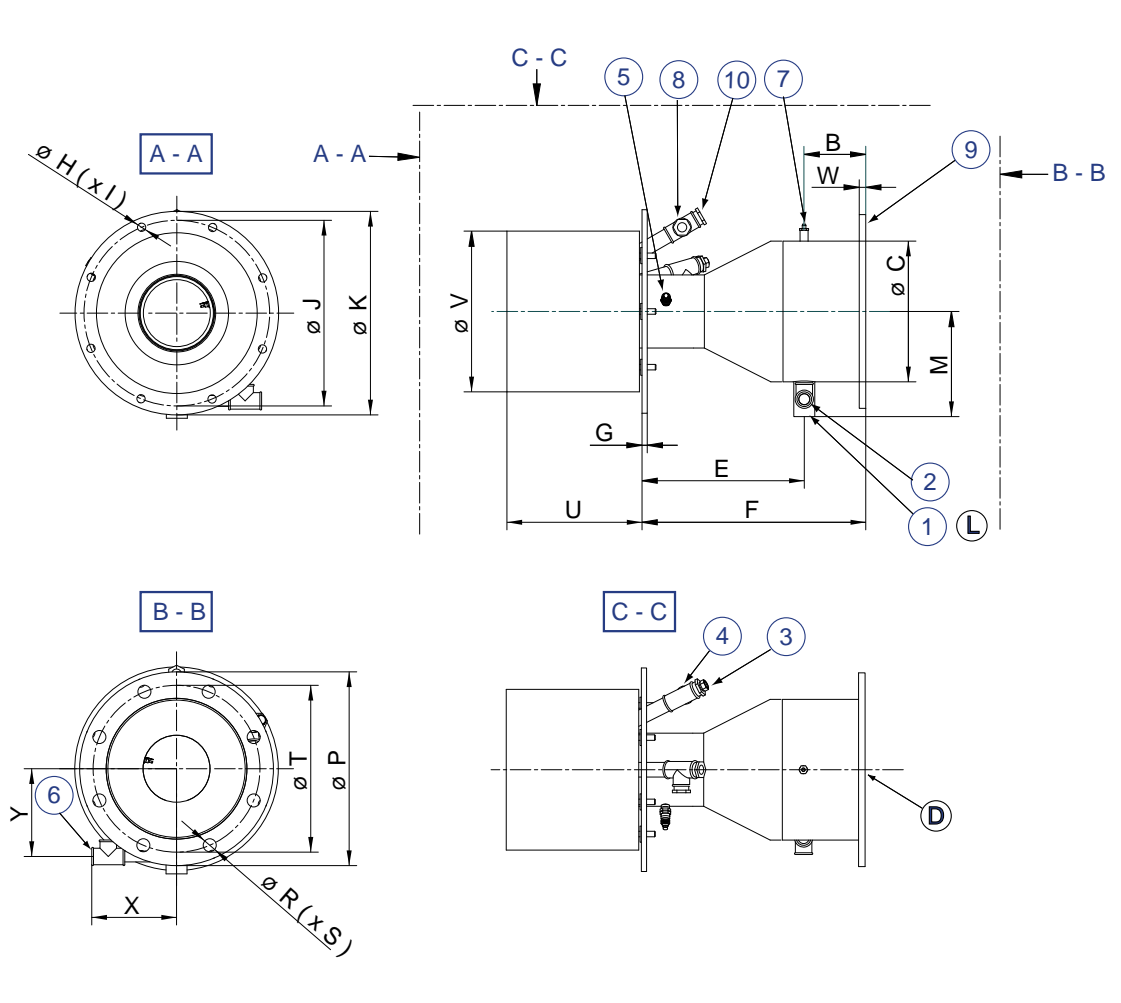

dimensions in in. unless stated otherwise												
Size	A NPT	B	C Ø	D pipe ANSI	E	F	G	H Ø	I # holes	J Ø	K Ø	L NPT [1]
.5M	3/8"	1.97	3.5	3"	5.7	7.86	0.25	0.625	8	10.73	12.0	1/2"
2.5M	3/8"	3.12	6.625	6"	6.94	10.06	0.375	0.625	8	12.52	14.15	1-1/4"
Size	M	N	P Ø	R Ø	S # holes	T Ø	U	V Ø	W	X	Y	Weight lbs
.5M	4.75	45°	7.5	.75	4	6.0	9.60	8.56	0.25	3.56	3.62	66
2.5M	6.25	22.5°	11	.875	8	9.5	9.60	10.42	0.25	4.49	4.63	100

[1] 1/2" NPT is female 1-1/4" NPT is male.

5M through 40M KINEDIZER® burners - ANSI

- 1) Main gas inlet
- 2) Pilot gas inlet
- 3) 1" NPT scanner connection
- 4) 1/4" NPT purge air connection
- 5) Spark ignitor
- 6) 1/4" NPT gas test connection
- 7) 1/4" NPT air test connection
- 8) 1/4" NPT chamber test connection
- 9) Optional air inlet flange
- 10) Observation port / alt. scanner position

Conforms to 150# ANSI Fig. Pattern\*. Bolt holes to straddle burner vertical & horizontal center-line.

material: 0.250 in. thK. carbon steel

\*Note: 40M air inlet flange does not follow ANSI bolt patterns. 9M through 40M air inlet flanges have elongated holes

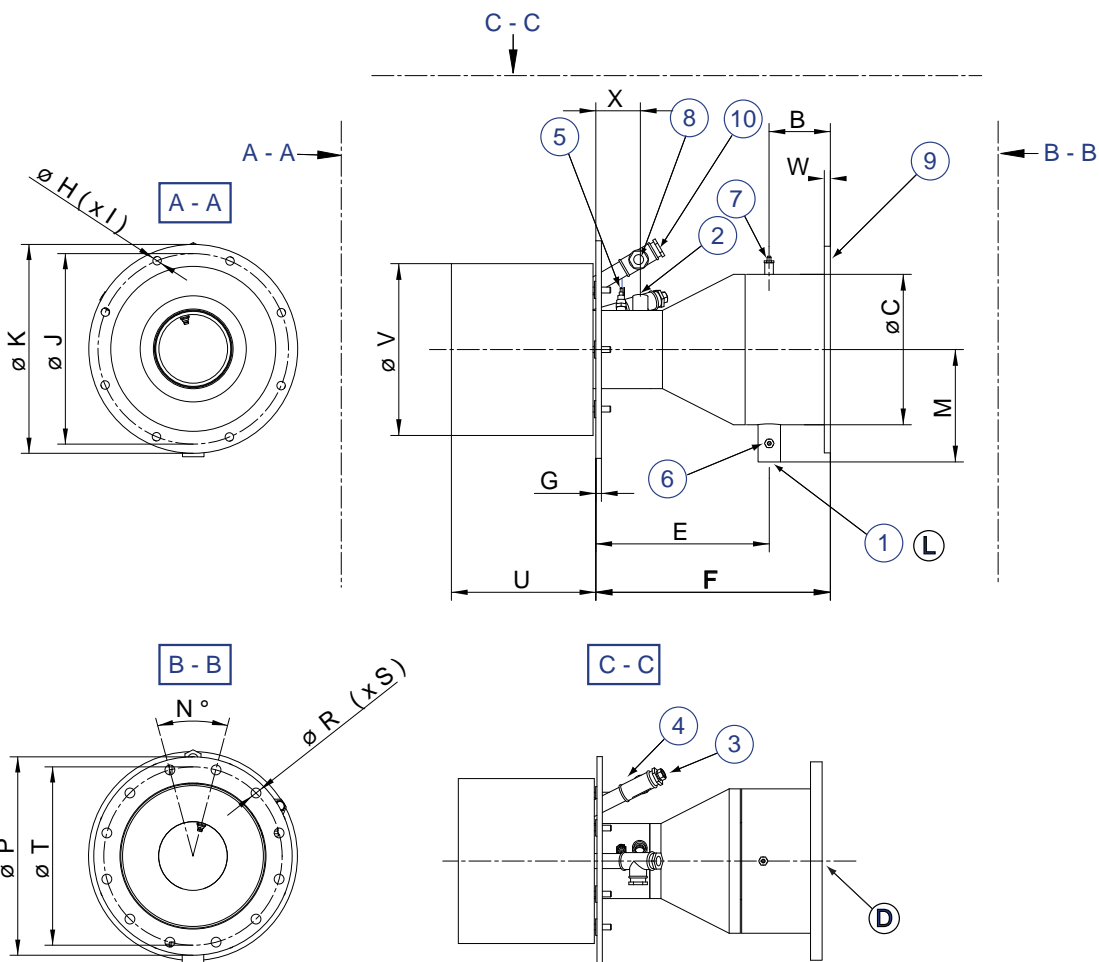

dimensions in in. unless stated otherwise

Size	A NPT	B	C $\phi$	D pipe ANSI	E	F	G	H $\phi$	I # holes	J $\phi$	K $\phi$	L NPT [1]
5M	3/8"	3.85	8.625	8"	11.24	15.09	0.375	5/8"	8	15.12	16.75	1-1/2"
9M	1/2"	5.0	12.75	12"	14.75	19.75	0.5	5/8"	8	16.82	18.45	3"
18M	3/4"	7.2	12.75	12"	18.35	24.73	0.5	5/8"	8	18.82	20.45	3"
27M	3/4"	7.2	18.0	18"	23.84	29.71	0.5	5/8"	8	20.95	22.57	4"
40M	3/4"	11.125	22.0	22"	37.09	48.21	0.5	5/8"	8	26.38	28.0	6"
Size	M	N	P $\phi$	R $\phi$	S # holes	T $\phi$	U	V	W	X	Weight lbs	
5M	7.50	22.5°	13.5	.875	8	11.75	9.60	12.95	0.25	2.68	165	
9M	12.5	22.5°	19	1	12	17	12.24	14.57	0.25	3.7	265	
18M	11.69	15°	19	1	12	17	12.24	16.57	0.25	4.31	331	
27M	14.31	15°	25	1.25	16	22.75	12.24	18.54	0.25	4.31	662	
40M	16.25	9°	25.75	0.562	20	24.13	12.12	23.94	0.25	4.31	922	

[1] 1-1/2" NPT is male, 4" (27M) and 6" (40M) gas inlets are 150# raised face flanges, not NPT

9M through 40M KINEDIZER® burners - ISO

- 1) Main gas inlet
- 2) Pilot gas inlet
- 3) 1" scanner connection
- 4) Spark ignitor
- 5) Gas test connection
- 6) Air test connection
- 7) Chamber test connection
- 8) Observation port / alt. scanner position

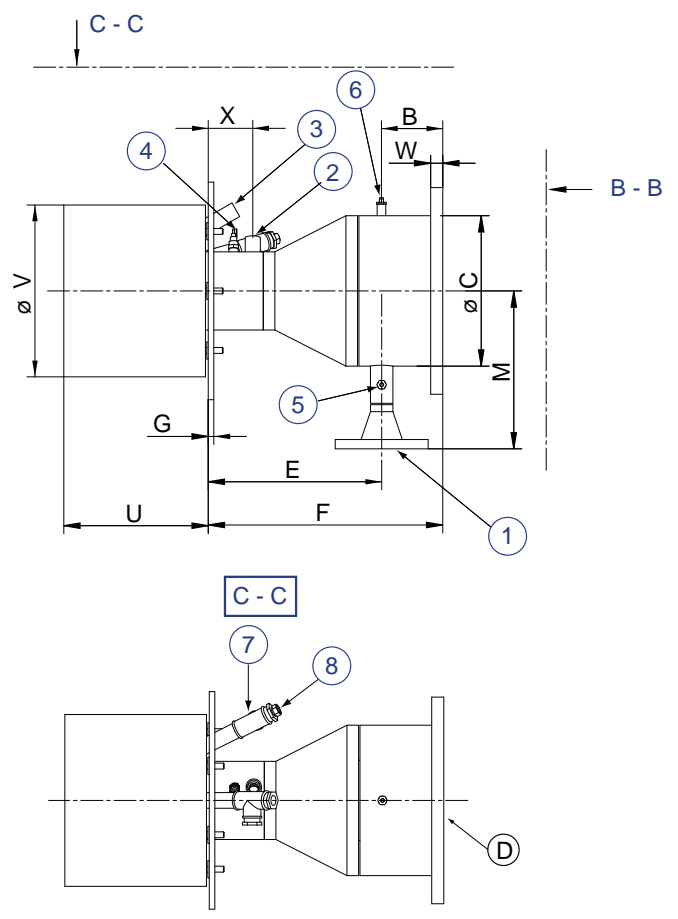
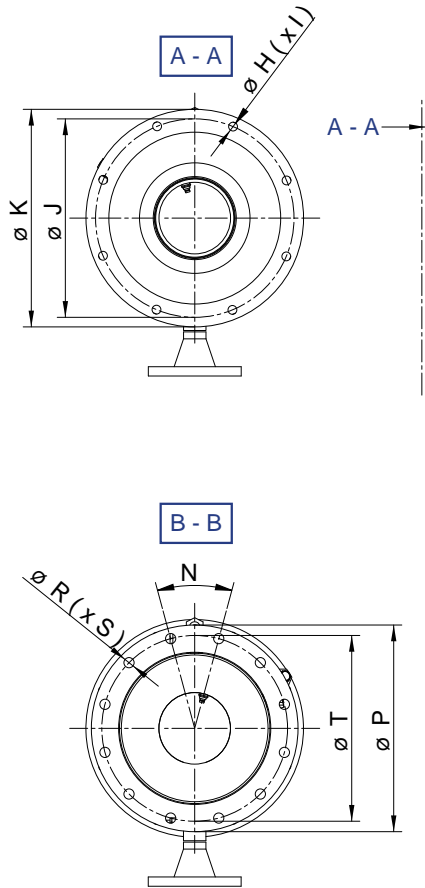

Dimensions in in. unless stated otherwise											
Size	B	C $\phi$	D air conn.	E	F	G	H $\phi$	I # holes	J $\phi$	K $\phi$	L gas conn.
9M	5.20	12.75	DN300	14.7	19.88	0.47	0.75	8	16.81	18.46	DN80
18M	7.40	12.75	DN300	16.42	22.91	0.47	0.75	8	18.82	20.43	DN80
27M	7.40	18.0	18"ANSI	23.74	29.88	0.47	0.75	8	20.94	22.56	DN100
40M	11.41	22.0	22"	37.04	48.35	0.47	0.75	8	26.38	27.99	DN150
Size	M	CC	EE	N	P $\phi$	R $\phi$	S # holes	T $\phi$	U	V $\phi$	Weight lbs
9M	13.39	3.78	1.0	45°	17.52	0.87	0.47	15.75	12.24	14.56	265
18M	12.0	4.29	1.0	45°	17.52	0.87	0.47	15.75	12.24	16.56	331
27M	16.34	4.37	0.47	22.5°	25.0	0.94	0.63	22.76	12.24	18.68	662
40M	16.5	4.29	0.47	18°	29.53	0.94	0.79	27.17	12.12	23.91	922

KINEDIZER® burners can be used in all orientations ( if accessories allow it ) - alternative positions for fuel gas inlet, pilot gas inlet or UV-scanner connection are not available. 40M burners are shipped with lifting lugs welded on the burner (not shown).