

Installation Instructions for Style A, B, C LINOFLAME® Burners

Important: Do not discard packing material until all loose items are accounted for.

General

LINOFLAME® Burner assemblies must be adequately supported and positioned. For small or simple burners, gas supply manifold may provide all the support needed.

In most cases, however, additional supports will be required. Avoid rigid mounting. Burner assembly expands and contracts with temperature variations, and rigid mounting creates severe stresses within the burner itself, its fastenings and/or supports.

Supports

If burner fires in still air:

Sketch 1 below illustrates a typical upward-firing position. It is only necessary to supply sufficient support to hold burner weight. In some circumstances, the manifolding itself may provide adequate support particularly if inlets occur every 4' or less.

Use cross-ignition end plates to sectionalize longer burner assemblies exceeding 7' in length.

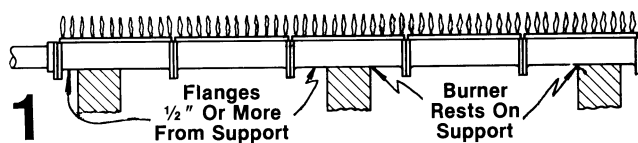

Burner location should be chosen to minimize possibility of plugging burner ports due to dirt, sand or other foreign matter being dropped onto the burner face.

To protect burner, a supply of fresh cooling secondary air should be provided, possibly as shown in **Sketch 2**.

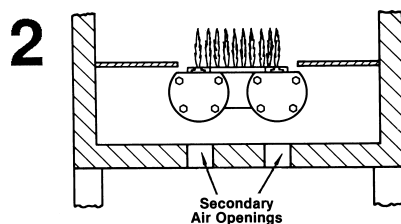

If burner fires into an air stream:

Burners must be mounted so they fire parallel to and in the same direction as the movement of the air which is being heated. (See **Sketch 3** at right.)

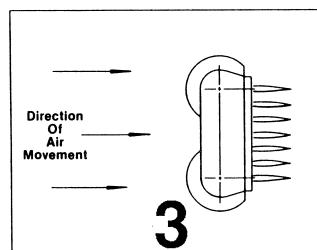

Maintain smooth, even air flow over the burner by designing supports to provide minimum interference, deflection and turbulence. Flat strap iron (with its width parallel to the direction of movement) is preferable to angle iron or channel supports.

In horizontal air streams, the preferred support methods depend on the type of burner configuration.

Small assemblies (up to 5' with one center-fed inlet, up to 10' with two inlets) can usually be supported from the gas piping only.

If **horizontal rows** of straight burner sections predominate, choose one of the two alternatives shown in **Sketches 4 and 5**.

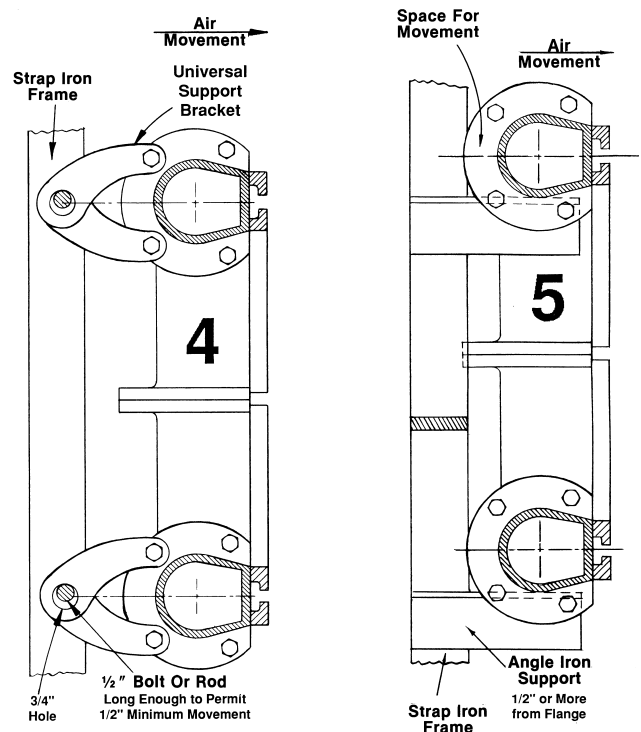

Sketch 4 shows the burner suspended from a strap iron frame using USB (universal support brackets) supplied by Maxon. Note that rigid mounting is avoided by the 3/4" bracket hole which slips loosely over a 1/2" bolt or steel rod attached to the support. Gas piping would need independent support.

Sketch 5 shows the burner assembly resting upon angle iron brackets and not attached to them in any way. Gas manifolding would be independently supported and prevent forward movement of the burner.

Installation Instructions for Style A, B, C LINOFLAME® Burners

If **vertical rows** of straight burner sections predominate, small assemblies (up to 10' of burner) can be supported from the gas manifold. For larger assemblies, see the examples below.

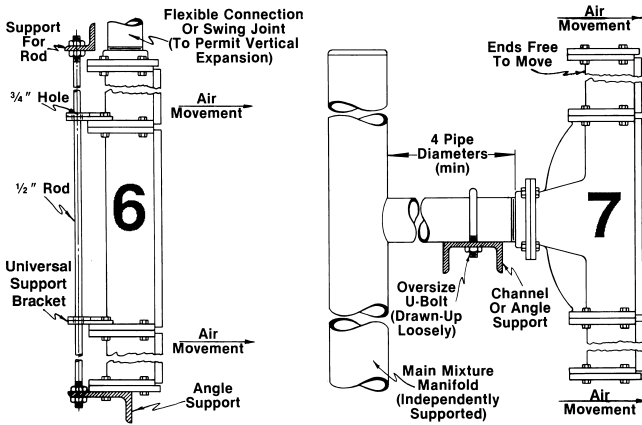

Sketch 6 shows angle iron used to support the burner. Note that narrow edge of angle faces air flow.
Sketch 7 shows how gas manifolding may be used to support the burner. If there are multiple inlets, you must avoid rigid connection by using the oversize U-bolt (loosely drawn-up) illustrated.

In **vertical air streams**, avoid upward-firing arrangements wherever possible. The increased chance of dirt falling into the burner (especially during a shut-down) can seriously affect performance and reliability. If unavoidable, however, support as shown in **Sketch 8**.

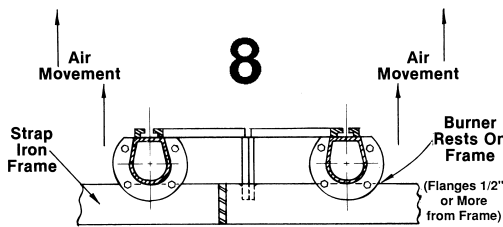

Support for down-fired burners can be accomplished as shown in the illustration at right. Always avoid rigid mounting.

Sketch 9 shows USB (universal support brackets) used to support the burner from an overhead angle iron. One advantage this provides is that the support mechanism may

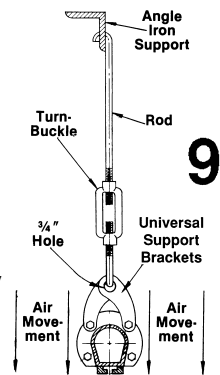

be moved back from the burner, thus minimizing any airstream turbulence or diversion that it might cause.

Sketch 10 shows an alternate arrangement which offers the advantage of more controlled positioning. This arrangement is especially good if the burner is to be installed in a heater which must be shipped to another location.

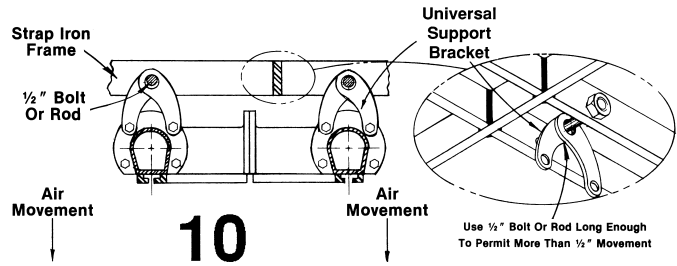

Pilots

LINOPAK Pilots bolt directly onto the burner in place of an end plate, already in proper position.

“Patch-on” pilots, when not factory-installed, must be mounted as shown in **Sketch 11** below, at a location suitable to you.

To **mount flame rod**, insert it in the flame rod bracket. Position bracket on burner side as shown below so that flame rod passes directly over a main burner port and mark the two mounting holes. Then drill 5/32" holes, tap them #10-24 and bolt flame rod bracket in place.

To **mount pilot hood**, position it as shown below (off-setting slightly to clear flame rod if ground vane is present), mark mounting holes and drill 13/64" holes, tap 1/4"-20 threads and bolt pilot hood in place.

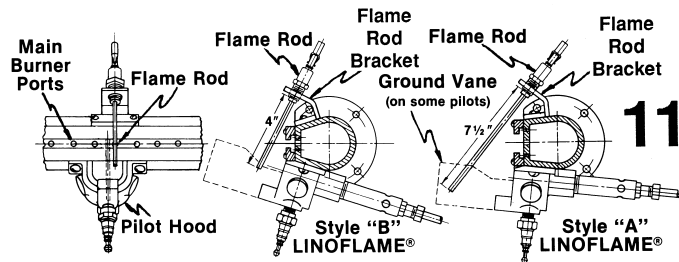

See also the gas train installation and start-up instructions for the particular proportioning and mixing equipment used in your system.

Distributed by:



888.858.3647 | relevantsolutions.com



CORPORATION
MUNCIE, INDIANA, USA

Maxon practices a policy of continuous product improvement. It reserves the right to alter specifications without prior notice.

INDUSTRIAL COMBUSTION EQUIPMENT AND VALVES