

Design and Application Details

Total heat release and LO-NOX™ Burner footage are normally selected from the tables given in the Series “HG” Mixing Tube section of the Maxon catalog (Section 3200).

Nominal burner capacity

Maximum: 550,000 Btu/hr per lineal foot
(requires 12" wc mixture pressure)
Minimum: 140,000 Btu/hr per lineal foot
(requires 0.8" wc mixture pressure)

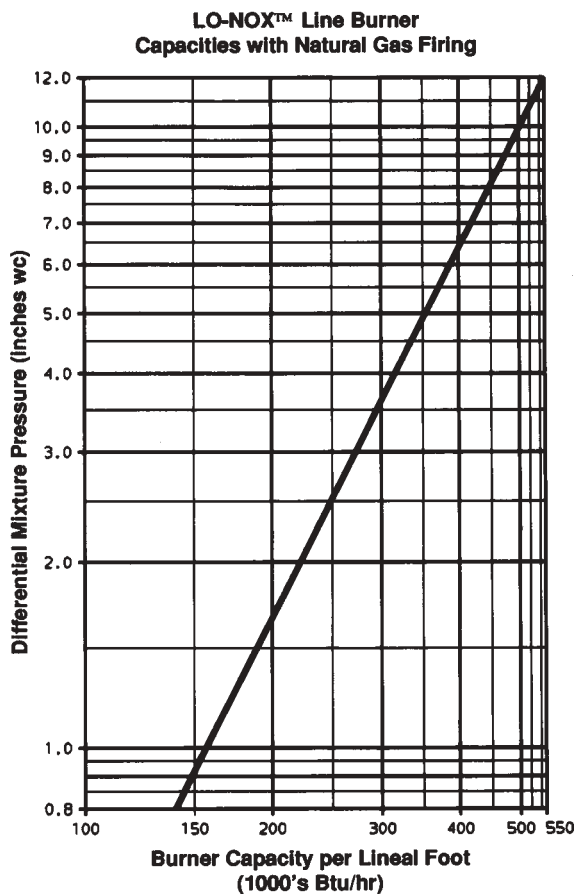

Based on information given in catalog section 3200, and within the constraints of duct size and air volume flows, a LO-NOX™ Line Burner assembly is designed utilizing the available sections shown on the following pages.

When ordering a burner assembly made up from the module components, be sure to provide an assembly sketch of the complete burner (as viewed from the back, or upstream, side) including locations of all accessories and/or individual component sections.

Burner duct area displacement

For purposes of calculating operating air velocities and resulting static pressure drops across the burner assembly and profile plate, use the following equivalent displacements:

Each 6" straight section:	0.35 ft ²
Each 12" straight section:	0.7 ft ²
Each 12" x 6" tee section:	0.75 ft ²
Each 12" x 12" cross section:	0.85 ft ²

For example:

A LO-NOX™ Line Burner assembly is made up of:

- (2) 12" straight sections @ 0.7 ft² displ. area
- (1) 12" back inlet straight @ 0.7 ft² displ. area
- (2) 12" x 6" tee sections @ 0.75 ft² displ. area

Total duct area displaced by this burner assembly:

$$(3 \times 0.7 \text{ ft}^2) + (2 \times 0.75 \text{ ft}^2) = 3.6 \text{ ft}^2$$

$$\text{Velocity (FPM)} = \frac{\text{Volume (CFM)}}{\text{Net Free Area (ft}^2\text{)}}$$

The net free area of the duct, and consequently the profile opening surrounding the burner element can be determined by inserting the air volume and/or the desired operating velocity into this formula. The burner displaces area in the duct and must be added to the air handling area to determine the appropriate profile dimensions.

Air stream velocity and resulting static pressure drop affect performance and are achieved by means of a silhouette profile plate within the duct.

A minimum profile plate width of 6" is required surrounding all LO-NOX™ Line Burner assemblies.

Air velocity over burner

Minimum	- 700 SFPM
Optimum	-1500 SFPM
Maximum	-3000 SFPM

NOTE: Burner is not sensitive to velocity variations within the desired range, but NOx levels may increase by 33% if fired at 600,000 Btu/hr, ft and at 3000 SFPM velocity.

Design and Application Details

Manifolding and Ductwork Considerations

Manifolding and ductwork considerations are extremely important in the design of LO-NOX™ systems. LO-NOX™ Burner systems can be susceptible to noise generation. In order to minimize the possibility of noise, we suggest the following:

- Adjust burner with a “fuel-lean” air/fuel ratio
- Burner element should be supported independently from the manifolding
- No flat transitions or turns should be made in ductwork downstream of burner
- All sheet metal ductwork should be rigidly fastened and have adequate stiffeners attached

Burner inlet feed piping must be adequate to provide a well-distributed flow of air/gas throughout the burner assembly.

- Be generous with inlet sections. Use enough to achieve a uniform mixture pressure within the burner.
- Use more 12" -B sections, and fewer crosses (which are most likely to generate noise problems).
- Keep manifolding symmetrical, with an extension beyond last “take-off” of at least 2 pipe diameters in length.

- Use flexible connectors if assembly includes more than 2 inlet feed sections.
- Keep main header at least 36" back from burner element to lessen chance of “shadow effect” on the air flow across the burner.

Do not exceed the footage feed limitations shown in the table below.

Inlet feed capacity limitations

Burner Inlet Flanges	LO-NOX™ Burner
2" end inlet flange	1 ft.
2" back inlet flange	
2.5" back inlet flange	1.5 ft.
3" back inlet flange	2 ft.
4" back inlet flange	
3" back inlet cross flange	
4" back inlet cross flange	4 ft.

Inlet flanges bolt directly to burner body casting and accept threaded NPT piping. Chart above shows maximum lineal feet of LO-NOX™ Line Burner that may be fed by a given inlet flange.

LO-NOX™ Line Burner Designation

Example: 12" x 12" BK INLET SECTION LN 5 - BX - D - 120

Section Description

LN = LO-NOX™ Line Burner

Mixing Plate Material

- 3 = #321 stainless steel
- 4 = #310 stainless steel
- 5 = Hastelloy-X

Section Code

- 6 = 6" straight section
- 12 = 12" straight section
- T = 12" x 6" tee section
- X = 12" x 12" cross section
- 12B = 12" back inlet straight section
- BX = 12" x 12" back inlet cross section

Body Material

- G = gray iron body
- D = ductile iron body

Number of (#30) drilled holes per lineal foot

120 = 120 holes (1.5564 in²/ft) discharge area

Capacity/Selection Data

LO-NOX™ Line Burners with Series “HG” Mixing Tubes

Fresh and recirculated air streams may be heated with LO-NOX™ Burners supplied with a full premixture of air and natural, propane, or butane gas.

A complete burner system to handle these applications would include a LO-NOX™ Line Burner assembly, Series “HG” Mixing Tube, MICRO-RATIO® Control Valve and a combustion air blower. Your Maxon representative can help you select from the broad range of options available.

General Selection Procedure:

1. Calculate gross heat requirement.
2. Determine burner footage and inlet feed requirements.
3. Enter Table 1 under column with your capacity needs for parameters of your application.
4. Select “HG” Mixing Tube size from Table 2 based upon the volume of air required.

Example:

– Required heat release of 7,000,000 Btu/hr

From Table 1

A. Gross heat required: 7,000,000 Btu/hr

B. $\frac{7,000,000 \text{ Btu}}{500,000 \text{ Btu/ft}} = 14 \text{ ft.}$

C. 14 ft. x 100 SCFM/ft = 1400 SCFM primary air with differential mixture pressure = 14" wc

From Table 2

D. Since single 8" “HG” Mixing Tube is rated for a maximum of 2500 SCFM, this requires (1) 8" “HG” Mixing Tube with gas orifices from Table 3.

E. Select MICRO-RATIO® Control Valve
 – For 1400 SCFM air = (84,000 SCFH)
 – For 7000 SCFH natural gas
 (See Maxon catalog bulletin 7000)

NOTE: Select gas control valve carefully to achieve maximum operating flexibility within its adjusting capability. Keep control valve size small so pressure drop through fully open valve at maximum flow capacity is within range of controllability.

F. If available inlet gas pressure is above 10 PSIG, consider double stage regulation to minimize droop.

Table 1: Design Parameters

Maximum capacity heat release Btu/hr per lineal foot of LO-NOX™ Burner	Combustion air required through "HG" Mixing Tube (SCFM per lineal foot of LO-NOX™ Burner) [1]	Differential mixture pressure (inches w.c.) as measured between burner inlet and duct/chamber static pressure
200,000	40	1.7
300,000	60	3.5
400,000	80	6.5
500,000	100	10
550,000	110	12

[1] This air volume is for a 12:1 air/gas ratio.

Table 2: Series "HG" Mixing Tube Selection

"HG" Mixing Tube Size	SCFM combustion air volume required at maximum through "HG" Mixing Tube
2"	0 to 190
3"	90 to 260
4"	175 to 500
6"	400 to 1167
8"	880 to 2500

Table 3: Gas Orifice Drillings for Series "HG" Mixing Tubes

NOTE: Drillings below based on 2 PSIG inlet gas pressure (measured at "HG" Mixing Tube gas inlet)

For fully premixed systems				Size of "HG" Mixing Tube (number of gas orifices in parentheses)
Combustion air pressure measured at air inlet of "HG" Mixing Tube	Gas orifice drillings for LO-NOX™ Burners			
	for Natural Gas	for Propane Gas	for Butane Gas	
8 osi	11/64"	9/64"	#29	2" HG (4)
12 osi	7/32"	#16	#18	
16 osi	15/64"	#11	#14	
8 osi	3/16"	#23	#27	3" HG (6)
12 osi	13/64"	#18	#22	
16 osi	7/32"	#15	#18	
8 osi	A	#12	#15	4" HG (8)
12 osi	F	#3	#8	
16 osi	J	#1	3/8"	
8 osi	F	#4	#8	6" HG (12)
12 osi	K	#1	7/32"	
16 osi	N	D	A	
8 osi	S	9/32"	17/64"	8" HG (12)
12 osi	13/32"	U	11/32"	
16 osi	15/32"	U	11/32"	

Envelope Dimensions (in inches) Modular Burner Sections



6" straight section



12" straight section



12" x 6" tee section



12" x 12" cross section

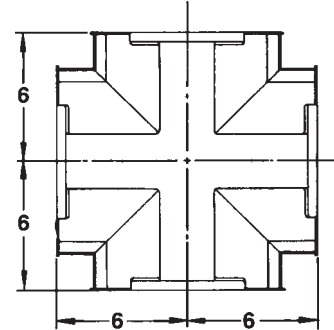
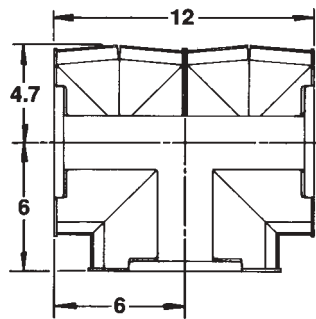
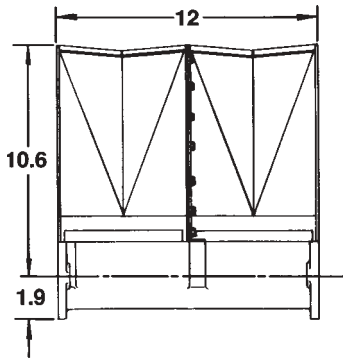
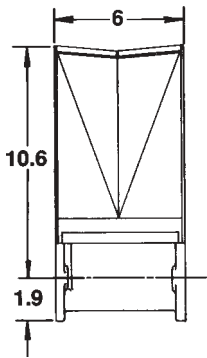

Typical End Views

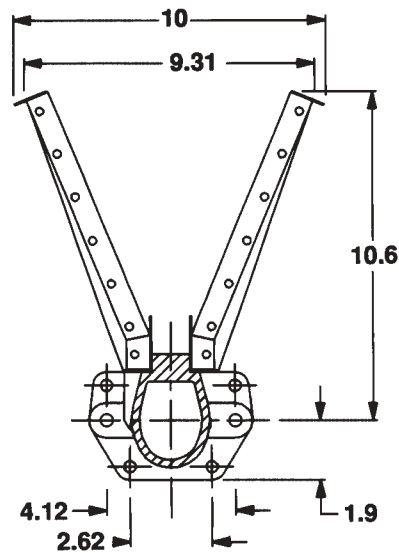

Straight Sections

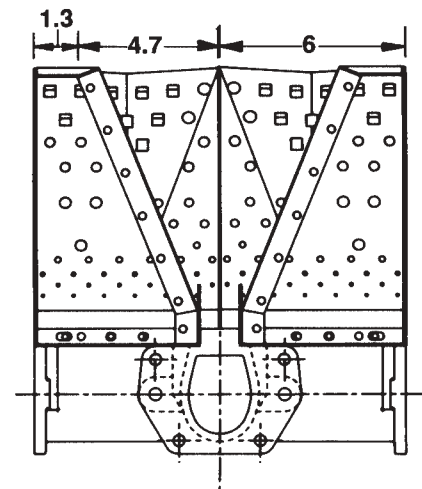

Tee and Cross Sections

Envelope Dimensions (in inches)

Modular Inlet Feed Burner Sections



12" back inlet section



12" x 12" back inlet cross

NOTE: 12B and XB back inlet sections must be ordered with one of the back inlet flange sets shown below.

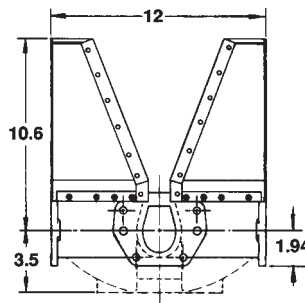
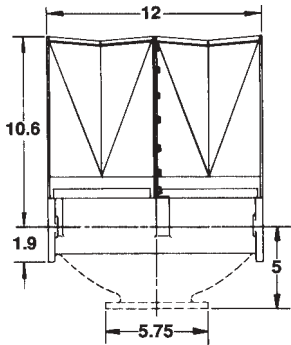

Back Inlet Flanges

Flange Sets for 12" Back Inlet Sections



Inlet flanges bolt directly to burner casting and accept either standard NPT or standard ISO threaded piping of indicated size.

NOTE: Refer to page 5804 for specific inlet feed capacity limitations.

Flange Sets for 12" x 12" Back Inlet Cross Sections

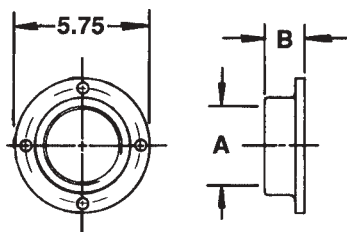

A (size)	B
2	0.88
2.5	1.25
3	
4	3.5

A (size)
3
4

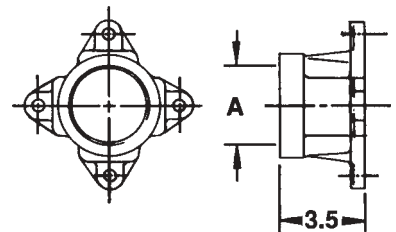

Envelope Dimensions (in inches)

End Closures and End Inlet Flange Sets

All open ends of a burner assembly must be closed off with one of these end closures, or with a pilot end plate or pilot assembly as shown below and on page 5809.

Plain end plate set

Plain end plate closure includes 1/8" NPT test connection

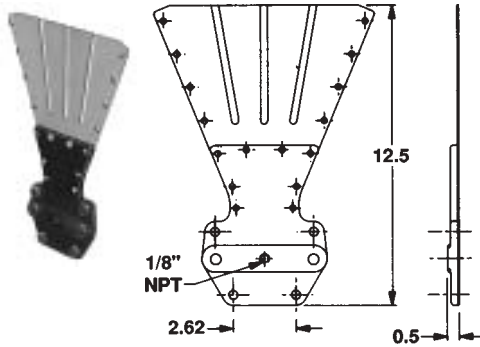

2" inlet set

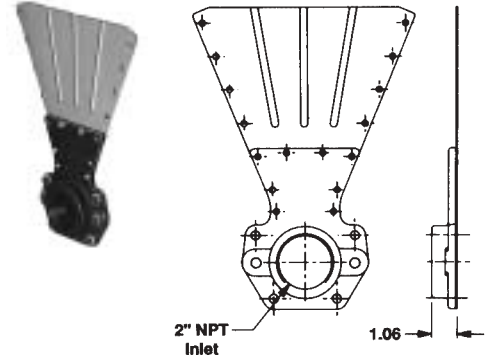

Pilot set

UV scanner can be mounted through straight-in flame rod location. 1" tap is bushed to 1/4" for flame rod.



Alternate flame rod position

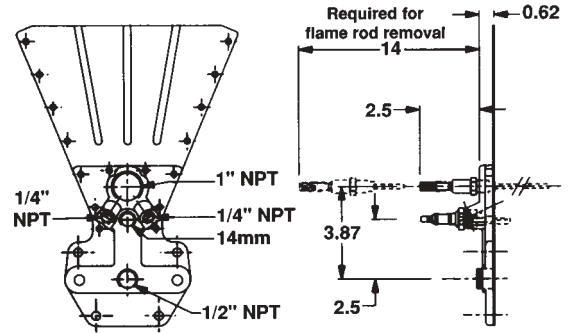

Flame rod (if used) must be ordered separately with all end plate and pilot sets.

2" inlet pilot set

UV scanner can be mounted through straight-in flame rod location. 1" tap is bushed to 1/4" for flame rod.



Alternate flame rod position

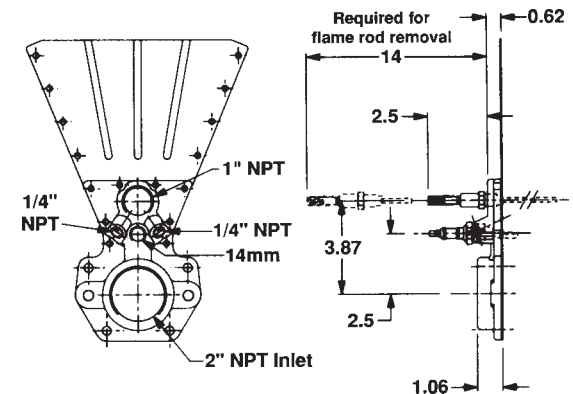

NOTE: See catalog page 5804 for specific inlet feed capacity limitations.

Dimensions (in inches) Pilot Assemblies

AIRFLO-PAK pilot arrangements

Direct mounted version includes 14mm spark ignitor. Order electrode separately for externally mounted version. Order flame rod (if used) separately.

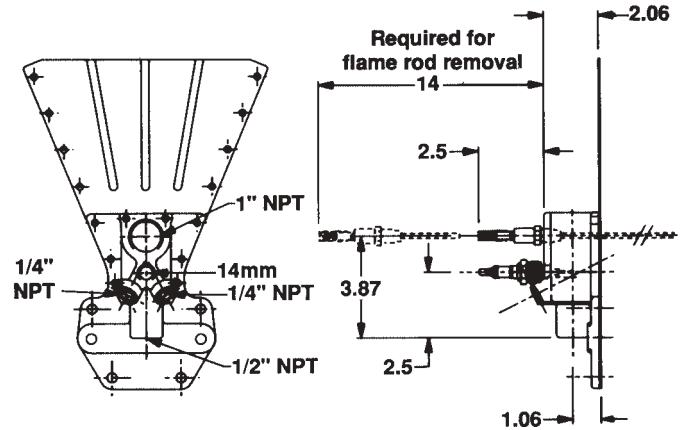

Optional air/gas pilot mixers for all LO-NOX™ pilot assemblies

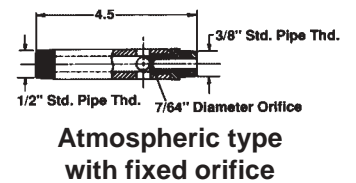
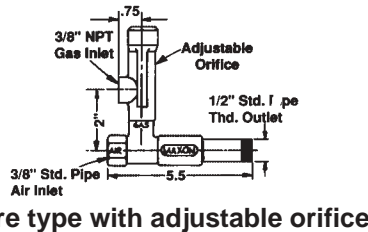
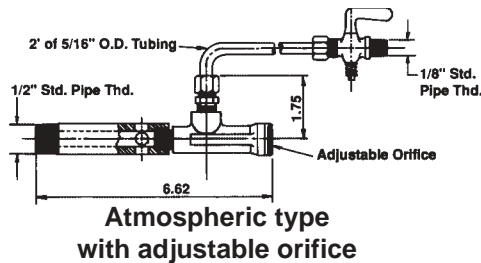

External Mounting Plate Assemblies as used with AIRFLO-PAK pilot assemblies

External mounting plate assembly for internal spark ignitor & internal flame rod

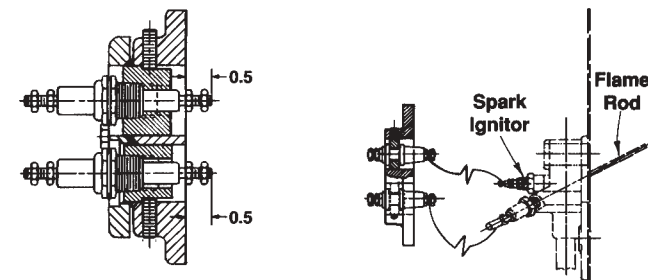

External mounting plate assembly for external spark electrode & external UV scanner

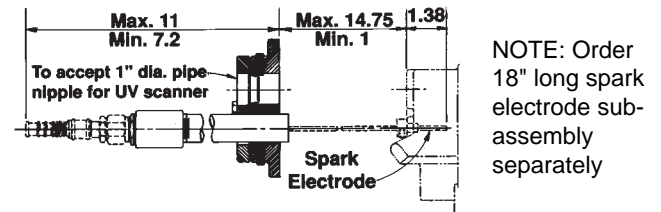

External mounting plate assembly for external UV scanner & internal spark ignitor

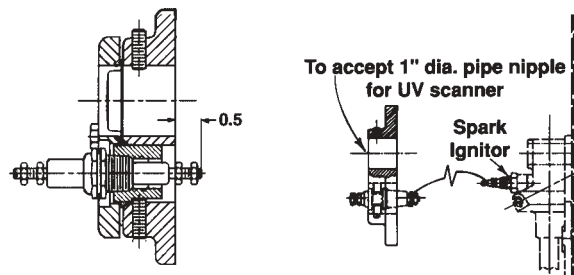

External mounting plate assembly for external flame rod & external spark ignitor

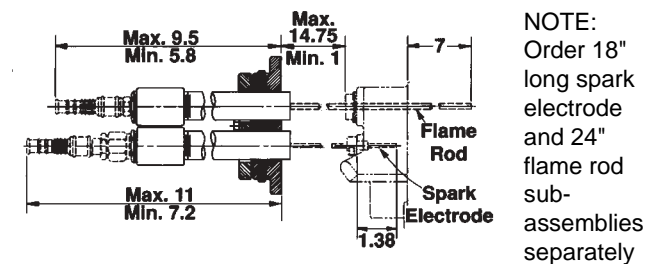

Dimensions (in inches) External Mounting Plate Assemblies

External mounting plate details

A plate is included with all assemblies shown on page 5809.



Mounting plate with two (2) feed-through insulators for internal mounting of spark ignitor and flame rod. Same size external mounting plate used in all assemblies shown on page 5809.

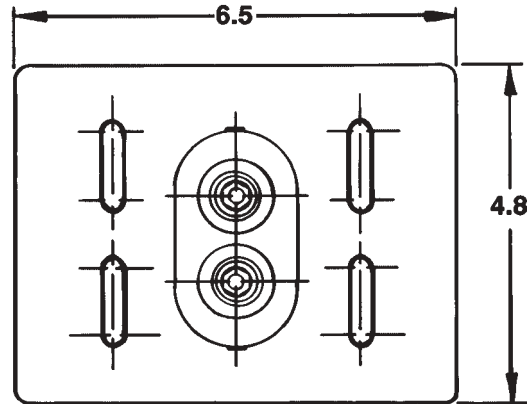

Positioning mounting plate in relation to LO-NOX™ Burner pilot location

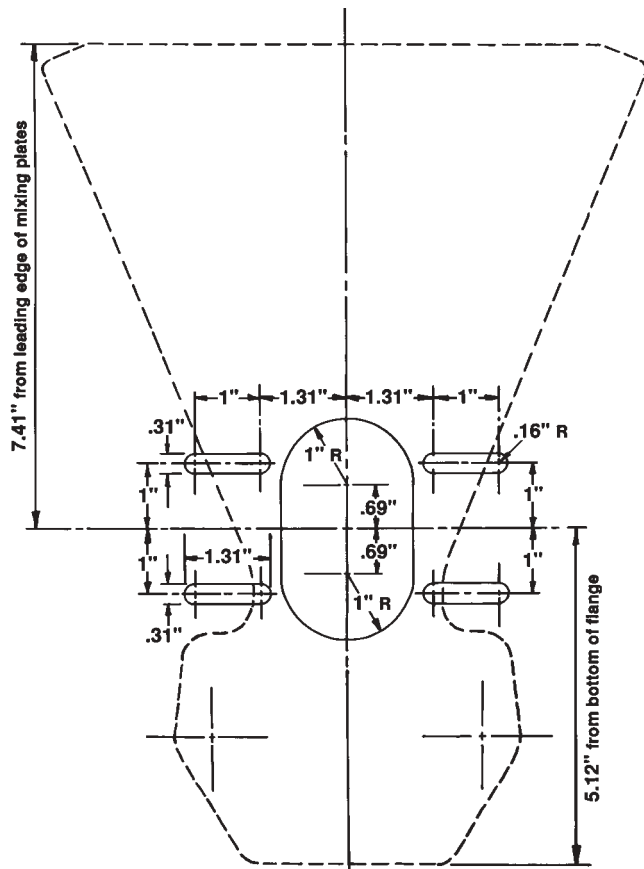

Through-wall opening required

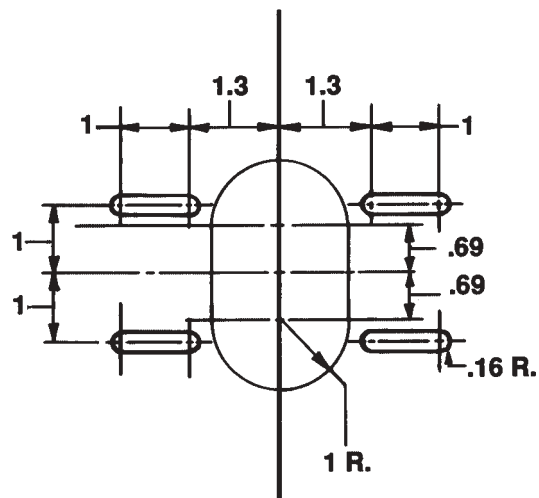

Accessory Dimensions (in inches)

Profile Plate Bracket

Provides support for profile within closed burner loop. On some applications, it may be necessary to restrict air flow between adjacent burner rows to achieve design operating velocities. This is done by installing customer-fabricated profile plates on profile mounting bracket(s). See **sketch 1** below for use on square openings (formed by adjacent cross-sections of burner). **Sketch 2** applies to rectangular opening.

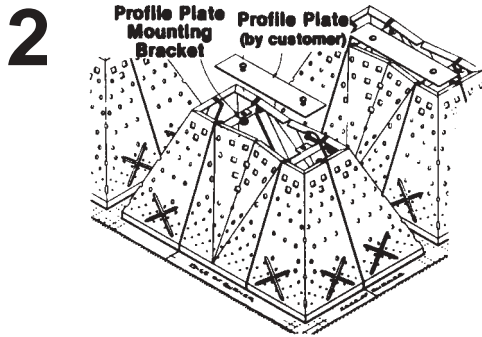
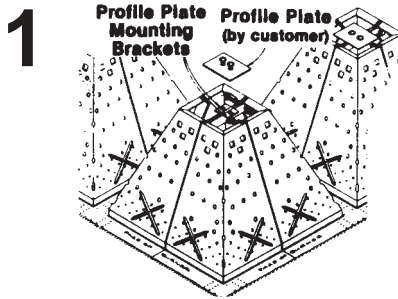
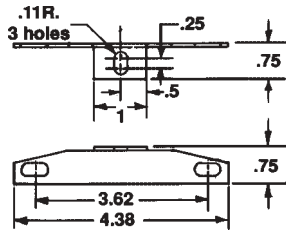

Universal support bracket

Normally used in pairs as shown below. Mount to burner assembly at any joint between sections. Two versions available: zinc plated carbon steel for maximum inlet temperature up to 750°F (399°C) or #304SS for maximum inlet temperature up to 1600°F (871°C).

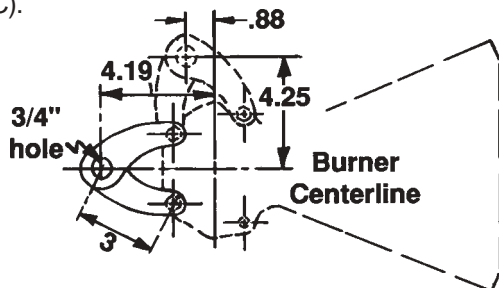

Division plate

Provides isolation of burner feed(s) where desirable.



Optional electrode cover

Protects porcelain insulator and electrical connection from dirt and moisture. May be used for ambient temperatures up to 450°F (232°C).



14mm Spark Ignitor

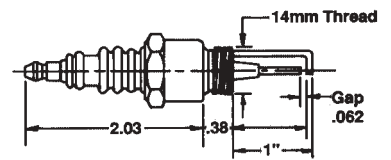

18" Spark Electrode

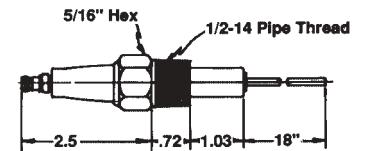

Flame rod identification

For those burners using flame rods, most applications are covered by one of three sizes (specific number depends on nominal length "N" of rod extension). These may need cut to dimension "L" specified in tables on pages 9908 and 9908A before use in your particular application.

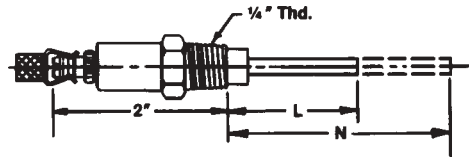

N
7-1/8"
12"
24"

Maintenance & Component Identification/Spare Parts

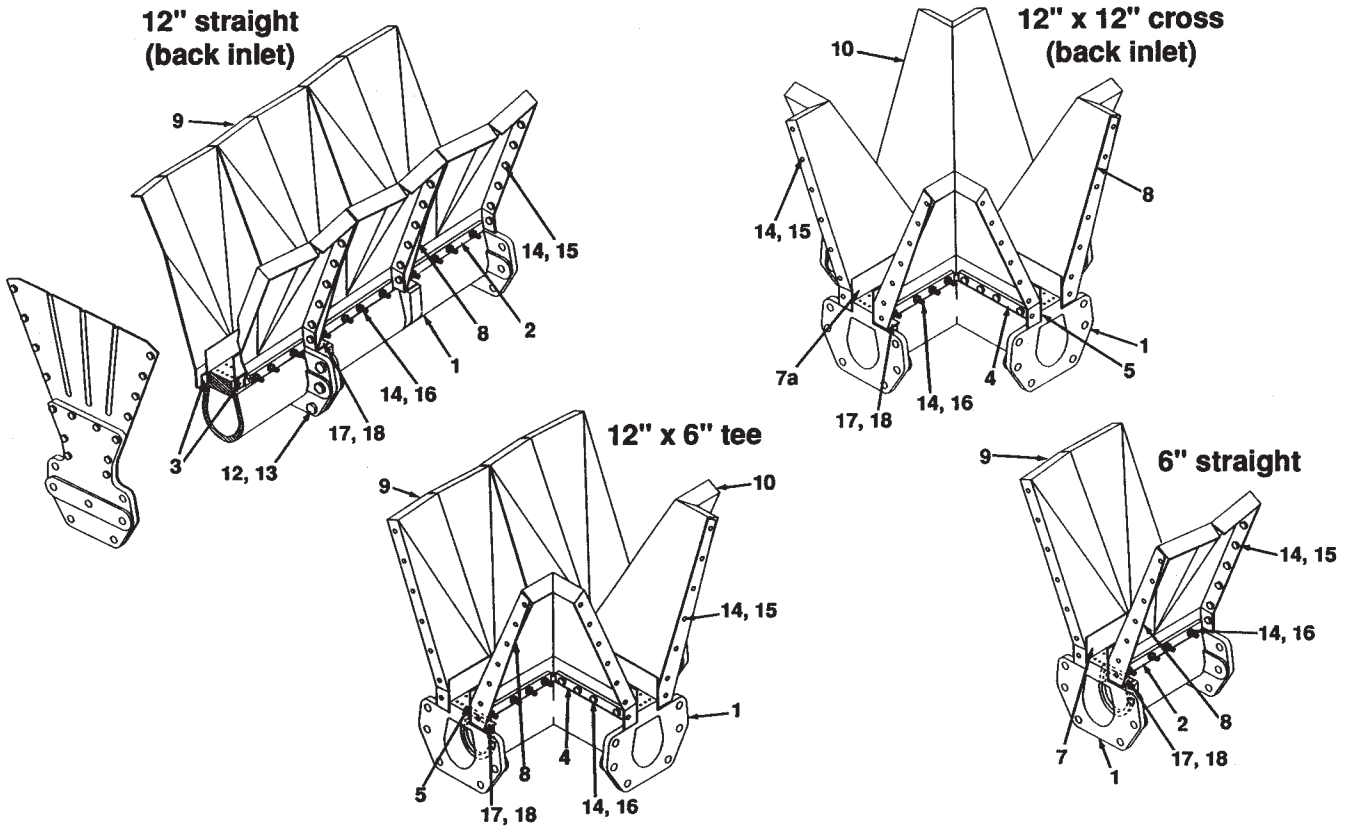

Item Number	Part Description
1	Burner body
2	Back up bar (straight)
3	Gasket, body (straight)
4	Back up bar (inside)
5	Gasket, inside
6	Back up bar (outside)
7	Flame protection rail (outside)
7a	Flame protection rail (inside)
8	Support bracket gasket 18 GA
9	6" mixing plate
10	Corner mixing plate
12	M10 - 1.5 x 45 hex head cap screw
13	M10 - 1.5 finished hex nut
14	#10 -24 FLEX-LOK hex nut
15	#10 -24 x 1/2" indented hex head machine screw
16	#10 -24 x 2-1/4" indented hex head machine screw
17	Washer
18	#10 -24 x 3/8" indented hex head machine screw

To order replacement parts:

1. Identify specific LO-NOX™ Burner series/type from burner assembly information plate pictured below.
2. Provide sketch of burner arrangement, as viewed from back (or casting side) of assembly. For example:

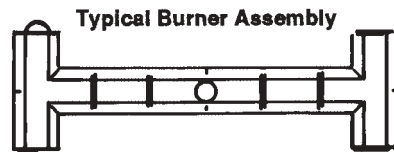

3. Specify quantity of each replacement item required from table at left.

LO-NOX™ Line Burner Information Plate

