

Specifications of OXY-THERM® LE burner

OXY-THERM® LE gas burners

Typical burner data					
Fuel: natural gas at 60°F with 1000 Btu/ft ³ (st) HHV - sg = 0.6 [1]					
propane at 60°F with 2500 Btu/ft ³ HHV - sg = 1.57 [1]					
Stated pressures are indicative. Actual pressures are a function of air humidity, altitude, type of fuel and gas quality.					
Gas OXY-THERM® LE Burners		OXY-THERM® LE Burners			
		Series 600	Series 900	Series 1200 [2]	
Maximum capacity range	MBtu/h	0.2 to 2.7	1.5 to 11	5 to 15 [3]	
Turndown		5:1			
Pressures required to burner inlet for maximum capacities	Oxygen	Refer to pressure curves on pages 3-18.1-11			
	Natural gas	psig	0.5-8 [4]		
	Propane	psig	1-20 [4]		
Typical oxygen to fuel volumetric ratios	To natural gas	2.05 to 1 [5]			
	To propane	5 to 1 [5]			
Approximate flame size	Diameter	inches	18	30	36
	Length	ft	2.2 - 2.0 per MBtu/h	2.0 - 1.6 per MBtu/h	2.0 - 1.3 per MBtu/h

[1] sg (specific gravity) = relative density to air (density air = 0.0763 lb/ft³ (st))

[2] Series 1200 not available in LE EX (extended block) version.

[3] Capacities greater than 15 MBtu are possible. Contact MAXON for specific details.

[4] Gas OXY-THERM® Burners are custom sized to meet your application and utility requirements. Please contact MAXON for specific details.

[5] Exact calorific values should be checked and oxygen/fuel ratio adjusted accordingly.

OXY-THERM® LE oil burners

Typical burner data								
Fuel: light oil (#2): 19.4 Btu/lb								
Stated pressures are indicative. Actual pressures are a function of air humidity, altitude, type of fuel and gas quality.								
Oil OXY-THERM® LE Burners	Series	Series 600 or 900	Series 900				Series 1200	
	Size	70	100	150	200	300	300	400
Maximum output	MBtu/h	3.1	4.4	7.5	10	14.9	14.9	19.9
Maximum fuel flow	gallons/h	21	30	52	69	103	103	137
Minimum fuel flow	gallons/h	4.2	6	10	15	26	26	34
Turndown		5:1	5:1	5:1	4.6:1	4:1	4:1	4:1
Atomizing oxygen/air/gas flow		Refer to pressure curves on page 3-18.1-12						
Oxygen pressure to burner inlet		Refer to pressure curves on pages 3-18.1-11						
Fuel pressure to burner at maximum		Refer to pressure curves on page 3-18.1-12						
Approximate flame diameter at maximum output	in	18	18	24	30	30	30	36
Approximate flame length at maximum output	ft	6	8	11.55	14	18	18	20

Materials of construction

Item number	Burner part	Material
1	Burner housing	Brass casting ASTM B145-61
2	Block [1]	Castable refractory alumina-zirconia-silica or castable refractory calcia stabilized zirconia
3	Gas body	Brass UNS C48500
4	Gas nozzle	440F Stainless steel ASTM A276-79
5	Mounting gasket	MICA composite 710-1
6	Block frame	Gray iron ASTM A159-77

[1] Extended block version only available in AZS block material

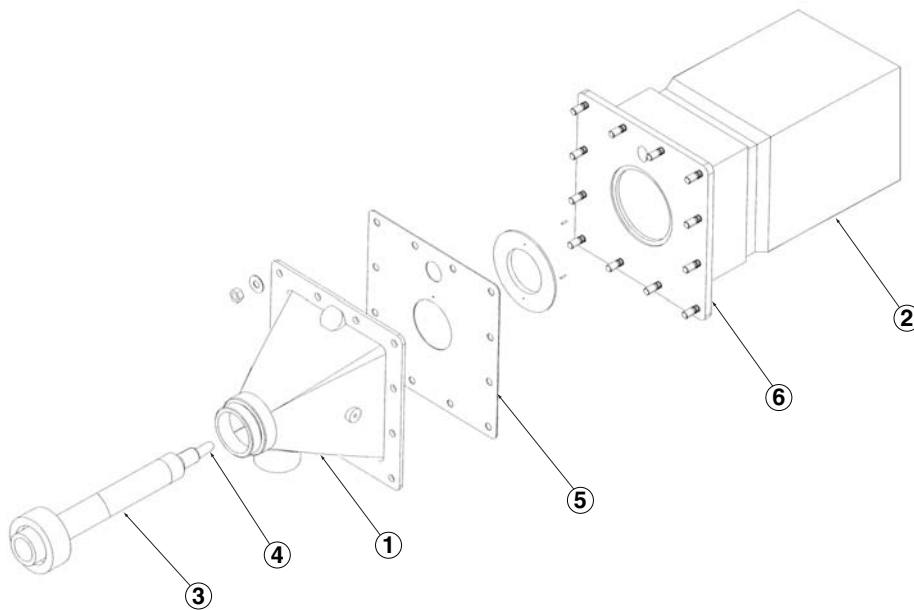

Selection criteria

OXY-THERM® LE burners are able to operate on gas, light oils or heavy oils. Each fuel requires the use of separate nozzle inserts. In some cases, fuel oils may be atomized by fuel gases allowing simultaneous firing of two fuels.

OXY-THERM® LE fuel inserts may be standard sizes or custom drilled for specific flame sizes and capacities. For custom drilled inserts, contact MAXON with information on your furnace dimensions, process, and capacity requirements.

Burner blocks are available in a variety of different materials and geometries to suit your application. Read "Burner blocks" on page 3-18.1-10 for more information on block selection.

Application details

OXY-THERM® LE burners can be used in furnaces and melters, steel reheat furnaces, reverberatory furnaces, and other high temperature applications.

OXY-THERM® LE burners have a unique design which allows fuel interchangeability and easy maintenance. With no tools, the burner fuel inserts can be removed or changed while the furnace is still in operation. With a large service nut and no tools, the burner fuel insert may be removed.



NOTE: Consult the installation and operation manual for safe removal of burner inserts. Use caution as extremely hot furnace gases will be present around typical burner installations.

Burner designation

The example below shows a typical OXY-THERM® LE burner designation along with the available choices for options and versions.

Burner	Series	Size		Fuel	Block material	Pilot
OT LE	9	15	-	2	A	O

BURNER

OT LE - OXY-THERM® LE

SERIES

6 - Series 600
9 - Series 900
12 - Series 1200

SIZE

00 - Gas burner (one size only)
07 - Oil burner size 70 (for Series 600 and 900)
10 - Oil burner size 100 (for Series 900)
15 - Oil burner size 150 (for Series 900)
20 - Oil burner size 200 (for Series 900)
30 - Oil burner size 300 (for Series 900 and 1200)
40 - Oil burner size 400 (for Series 1200)

FUEL

N - Natural gas
O - Other gas (see Engineering)
P - Propane gas
2 - #2 fuel oil
6 - Preheated #6 fuel oil

BLOCK MATERIAL

A - Alumina/zirconia/silica
Z - Zirconia

PILOT

N - No pilot chosen
O - Oxy pilot without UV location
U - Oxy pilot with UV location

Process temperatures

OXY-THERM® LE burners may be applied to furnace temperatures up to 3200°F with standard block materials. For higher temperatures, special block materials are available. Refer to "Burner blocks" for more details.

Cooling flow, either clean, dry air or oxygen, must be used whenever the burner assembly is in a high temperature atmosphere and is not firing. See installation and operating instructions for more details.

Process flows and oxygen content

The OXY-THERM® LE burner requires no additional oxygen for complete, clean combustion beyond the oxygen fed through the burner.

In applications with heavy drafts or process flows, the burner flame will be moved by the atmosphere motion. Do not allow oxy-fuel flames to contact furnace walls or product as this may damage refractories and other materials.

Piloting & ignition

Use the optional oxy-fuel pilot only. (Refer to page 3-18.1-16 for dimensions.)

Oxy-fuel pilot specifications			
Fuel	Flow cfh	Pressure " wc	Capacity Btu/h
Natural gas	25	2.25	25,000
Propane	10	0.83	
Oxygen	53	0.5	

Ratio control

Correct fuel/oxygen ratio control valves should be selected. Trims should be selected to enable the use with oxygen. MAXON's MICRO-RATIO® valves are available with oxygen trim. For more accurate ratio control, use MAXON SMARTLINK® MRV valves, or for best performance, use SMARTFIRE® Intelligent Combustion Control System. Calibrated flowmeters in the fuel and the oxygen lines are recommended for establishing accurate volumetric flow rates.

Burner blocks

Two refractory block materials are available for OXY-THERM® LE Burners. Alumina/zirconia/silica (AZS) burner blocks and zirconia burner blocks may be used with gas firing and oil firing.

Series 600 and Series 900 burner blocks are available in a standard length and an extended length version. Extended length blocks are only available in AZS material. See "Dimensions and weights" on pages 3-18.1-14 and -15.

Block material		
Type	Alumina/zirconia/silica (AZS)	Zirconia
Maximum temperature	3002°F	3200°F

In addition to maximum furnace temperatures, temperature variations and furnace atmosphere (chemical composition) can also be factors used to determine the appropriate block material.

Combustion oxygen pressure vs. flow

OXY-THERM® LE burners may be adjusted to operate on ratio, with excess oxygen (oxidizing environment) or with excess fuel (reducing environment). Typical applications will operate with 1-2% excess oxygen.

If burners are shut down while the furnace remains hot, it is recommended to continue a small flow of oxygen for cooling of the burner. Alternatively, air or nitrogen can be used for burner cooling during burner shut down. Total elimination of oxygen flow in hot furnaces can thermally damage burner fuel inserts and other parts. For extended shutdowns in hot furnaces, it is recommended that the fuel insert be removed and the burner fuel pathway be sealed with the service nut shipped with each burner.

Combustion oxygen pressure - gas burner

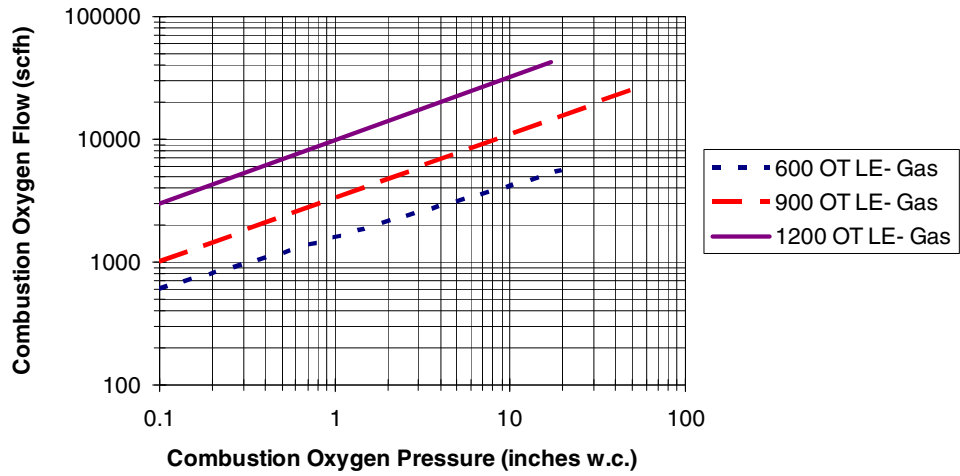

Combustion oxygen pressure - oil burner

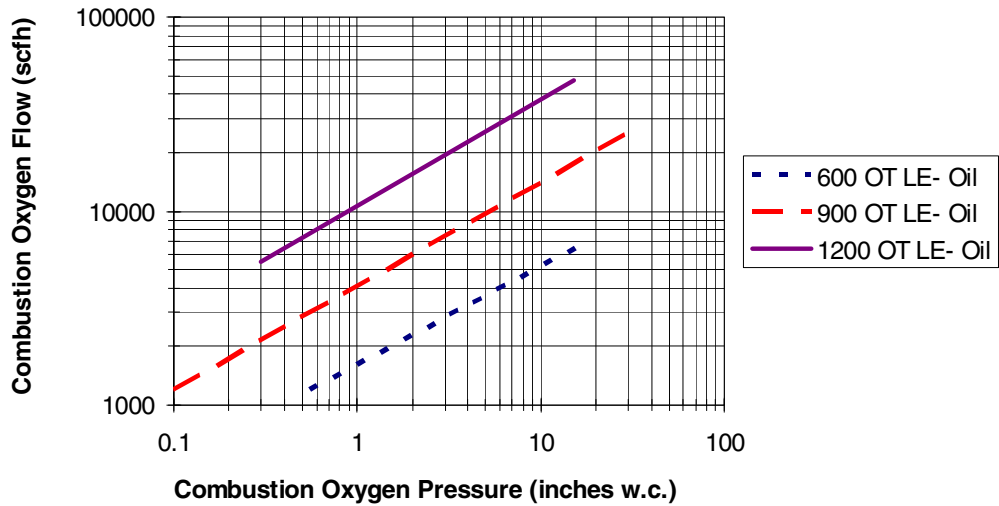

Oil OXY-THERM® LE burners - atomizing oxygen/air flow vs. pressure

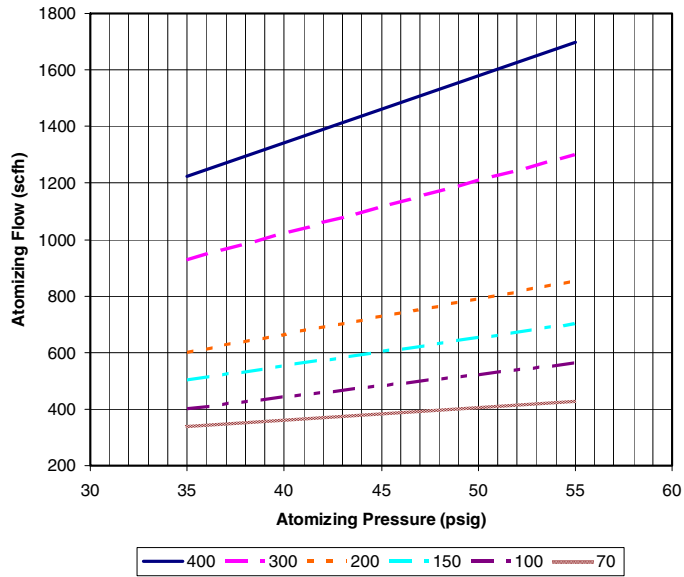

Oil OXY-THERM® LE burners - fuel oil flow vs. pressure

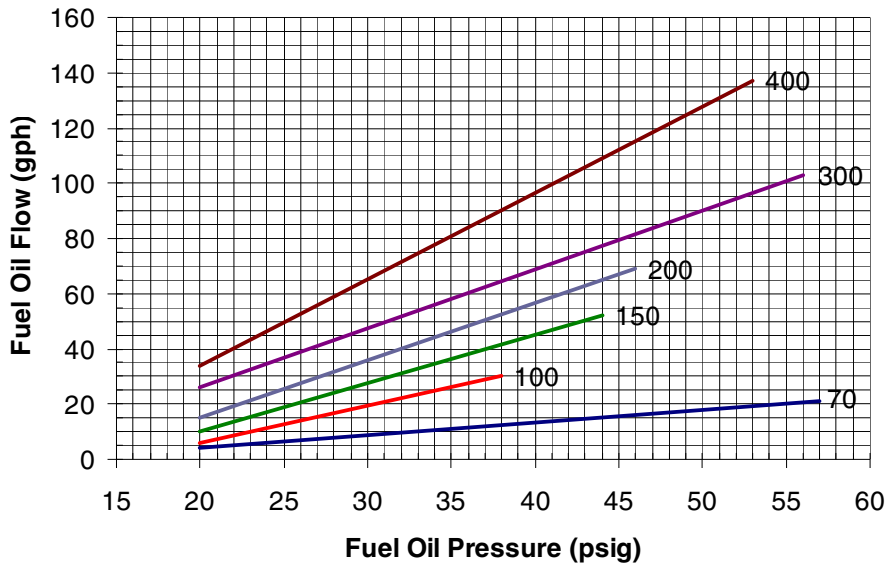

Typical ignition sequence

- Pre-purge of burner and installation, according to the applicable codes and the installation's requirements.
- Combustion oxygen control valve shall be in the minimum position to allow minimum oxygen flow to the burner.
- In case of oil firing: Atomizing oxygen/air/gas should be applied to the burner. If a burner with optional pilot burner is used, execute the following three steps.
- Pre-ignition (typically 2s sparking in air).
- Open pilot gas and continue to spark the ignitor (typically 5s). Trip burner if no flame can be detected from here on.
- Check pilot flame stability (typical 5s to prove the stable pilot).
- Open main gas or oil valves and allow enough time to have main gas or oil in the burner (typical 5s + time required to have main gas or oil in the burner).
- Close the pilot gas valves (in case a pilot burner is used).
- Release to modulation (allow modulation of the burner).

Flame supervision

Flame scanning is possible down the gas nozzle. The flame scanner cannot be used through the pilot location to see the main flame. The use of a flame rod for flame detection is not possible.

In case of oil firing where flame supervision is required, contact MAXON for alternative options.

Piping

Burner and piping should be supported as shown in the installation instructions. Unsupported piping puts stresses on the block/frame assembly resulting in block failure.

Fuels

OXY-THERM® LE burners are designed for firing on any clean fuel gas or light and heavy oils.

Expected emissions

OXY-THERM® LE burners utilize a patented oxygen staging technology to reduce the formation of NOx in high temperature furnaces. Through deep staging of the oxidant flow, NOx is controlled to levels typically lower than less advanced oxy-fuel burners. By reduction in total flue gas volume, the total mass of NOx created is often lower than air fuel firing.

Best results are achieved in furnaces which are sealed tight from ambient air infiltration or running a slight positive pressure to prevent the infiltration of nitrogen compounds. Results will vary widely by application. Contact MAXON for estimates and consultation on best practice.

Exact emissions performance may vary in your application. Contact MAXON for information on installation-specific estimates and guaranteed values. No guarantee of emissions is intended or implied without specific, written guarantee from MAXON.

Dimensions and weights

OXY-THERM® LE gas or oil burners

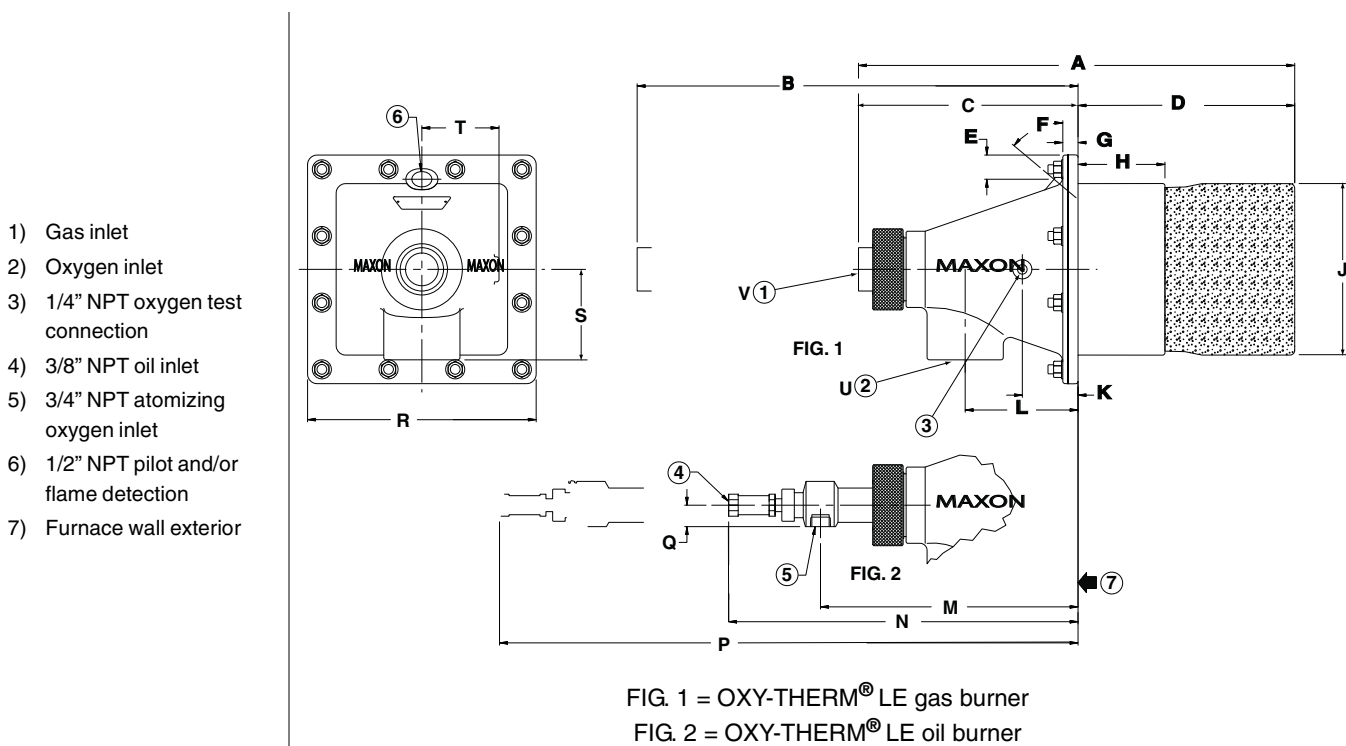

Dimensions in inches unless stated otherwise

Burner series	A	B [1]	C	D	E	F	G	H	J sq.	K	L
600	16.4	16.5	7.78	8.63	1.23	58°	0.9	3.25	6.06	1.93	3.18
900	22.9	24.0	11.52	11.38	1.28	50°	0.9	4.56	9.0	2.92	5.92
1200	22.9	24.0	11.52	11.38	1.28	50°	0.9	4.56	12.0	2.92	5.92

Burner series	M	N	P [1]	Q	R sq.	S	T	U NPT	V NPT	Weight lbs	
										AZS	Zirc
600	8.91	15.15	24.5	---	9.0	---	---	1-1/4"	1"	65	95
900	13.52	18.34	31.0	1.13	12.06	4.75	4.13	3"	1-1/2"	160	225
1200	13.52	18.34	31.0	1.13	12.06	4.75	4.13	3"	1-1/2"	225	340

[1] Removal clearance

OXY-THERM® LE EX (extended block) gas or oil burners

- 1) Gas inlet
- 2) Oxygen inlet
- 3) 1/4" NPT oxygen test connection
- 4) 3/8" NPT oil inlet
- 5) 3/4" NPT atomizing oxygen inlet
- 6) Furnace wall exterior

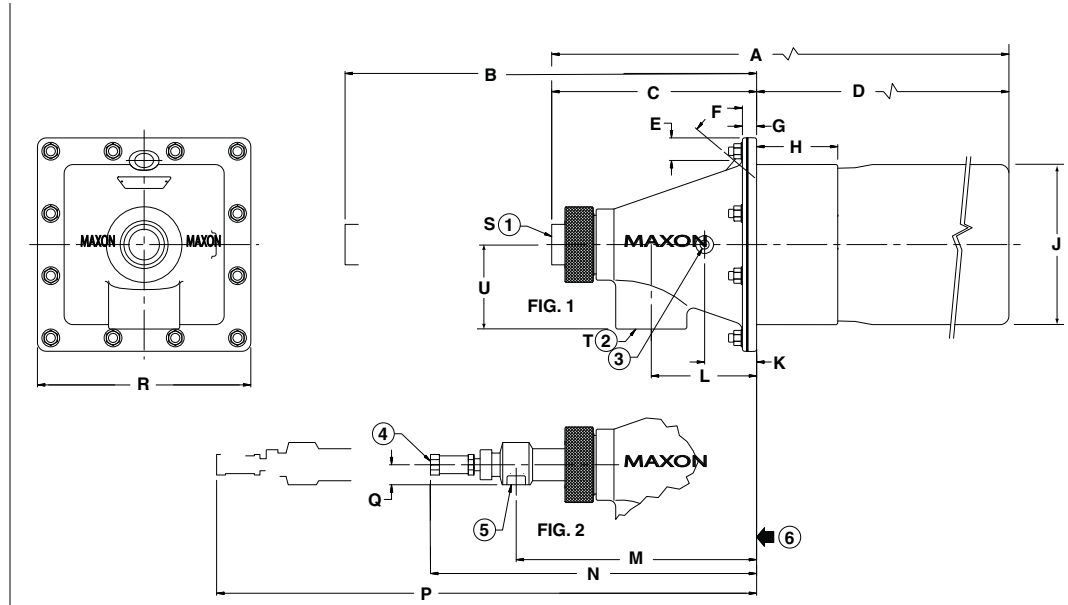

FIG. 1 = OXY-THERM® LE EX gas burner

FIG. 2 = OXY-THERM® LE EX oil burner

Dimensions in inches unless stated otherwise											
Burner series	A	B [1]	C	D	E	F	G	H	J sq.	K	L
600	25.67	25.73	7.67	18.0	1.23	58°	0.9	3.25	6.0	1.93	3.18
900	29.52	29.88	11.52	18.0	1.28	50°	0.9	4.56	9.0	2.92	5.92

Burner series	M	N	P [1]	Q	R sq.	S NPT	T NPT	U	Weight lbs	
									AZS	
600	9.0	15.6	33.87	---	9.0	1"	1-1/4"	3.0		98
900	13.68	18.74	37.34	1.13	12.0	1-1/2"	3"	4.75		200

[1] Removal clearance

Accessories

Oxy-pilot

- 1) 1/2" NPT
- 2) 3/8" NPT (fuel inlet)
- 3) Spark ignitor
- 4) 1/2" NPT (oxygen inlet)

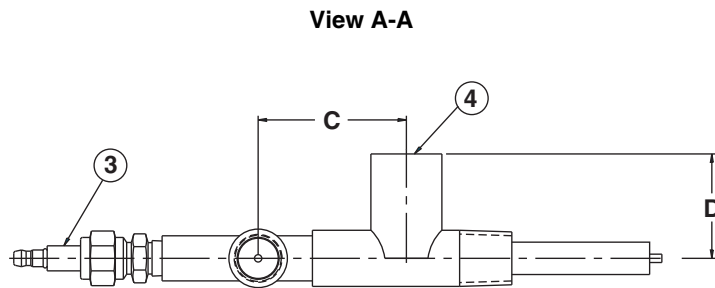
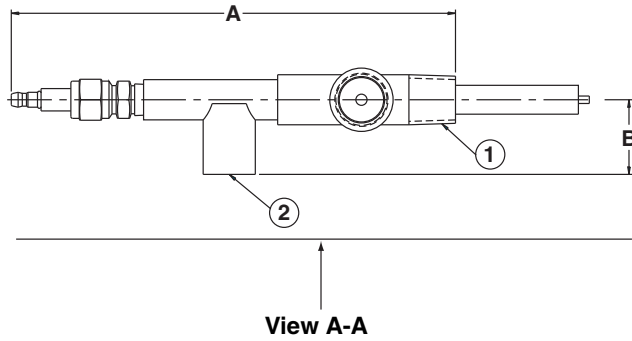

Dimensions in inches unless stated otherwise

A	B	C	D
7.5	1.3	2.2	1.6

Installation and operating instructions for OXY-THERM® LE Burners

Application requirements

View port

A view port to observe burner flame is essential to inspect flame aspect. Locate the view port downstream of the flame, looking back to the burner block. Make sure the complete flame can be evaluated.

Support burner air and gas piping

The OXY-THERM® LE burner shall not be used as support for the piping to the burner. Gas and air piping shall be supported in such a way that no additional loads will be created on the burner. Flexible connections are typically recommended for all OXY-THERM® installations for both fuel and oxygen to prevent transferring mechanical loads or vibrations to the burner's ceramic parts.

Burner mounting flange loads

Check burner weight and reinforce burner mounting flange or combustion chamber/furnace back wall if necessary to accept complete burner weight.

Installation instructions

Storage of OXY-THERM® LE Burners

OXY-THERM® LE Burners shall be stored dry (inside). Burner blocks have been cured carefully before shipment and shall be kept dry. Wetting of the blocks could result in premature failures.

Handling of OXY-THERM® LE Burners

OXY-THERM® LE Burners are shipped as complete units. Handle burners with care, using proper equipment, during unpacking, transport, lifting and installation. Any impact on the burner could result in damage.

Burner mounting

The sketch below shows one possible method of mounting and holding an OXY-THERM® LE Burner block and frame assembly in place. Other methods are possible.

- 1) Furnace wall
- 2) Burner frame
- 3) Melter wall
- 4) Burner block
- 5) Shims
- 6) Structural member of melter
- 7) Threaded rods for compressing burner frame to side of melter
- 8) Burner reinforcement plates

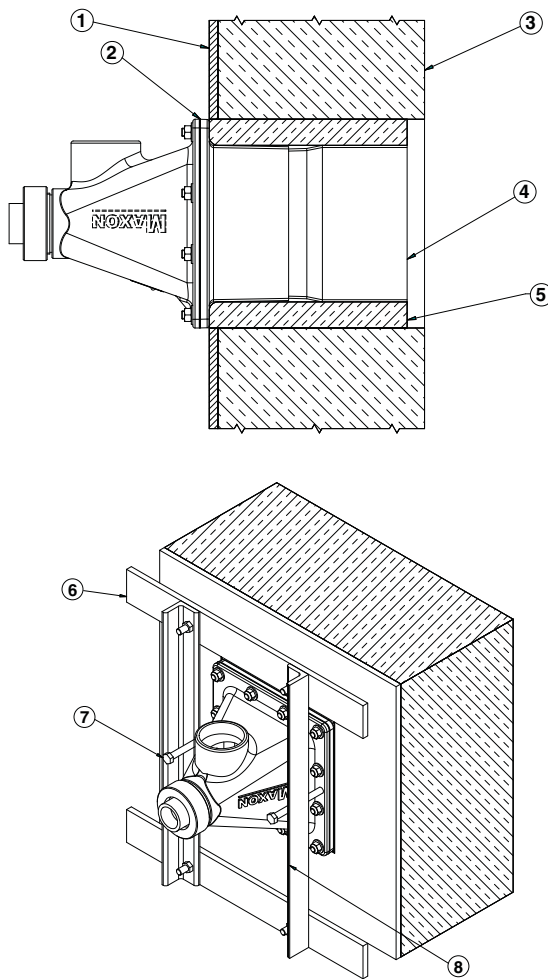

Burners should not be installed in a down-fired position. If this mounting arrangement is required, please contact MAXON for additional assistance.

The primary objective is to compress the frame against the wall of the melter and to support the weight of any system piping.

The burner block sits on the sill or wall. The block must rest flat on the sill or wall without rocking to allow weight to be equally distributed. Failure to do so could result in cracking and block failure. If burner port holes are too large, shims may be used to align the burner.

Burner block failure could result from external forces and stresses transmitted to the burner through the piping. Under no circumstances should the burner be the only support for the piping. Flexible connections are recommended in all piping to reduce piping stresses and alignment/shifting problems. Installation of such connectors at certain key spots in the oxygen or gas manifolding can prevent damage to the burners from uneven thermal expansion.

The opening of the furnace wall should provide 1/16" clearance on all sides. High temperature furnace sealant or gasketing should be used between burner mounting flange and furnace wall.



For maximum burner life, burner frame must be protected from hot gases.

Burner installation procedure

Read the entire installation procedure before proceeding with the installation of oxygen-fuel burners.



Failure to follow the proper installation sequence noted below could result in damage or destruction of vital burner components. Cooling oxygen or air flows should be present at all times when the burner housing and metal components are mounted to a hot furnace.

To prevent damage in transit, the fuel inserts, mounting gaskets and burner housing may be packed separately. In most cases, the burner will be shipped assembled but with the mounting nuts only finger-tight. In either case, the burner block and frame will need to be disassembled from the rest of the burner to allow installation of the block into the furnace wall.



NOTE: A 3/4" socket is required for mounting nuts. A manual speed wrench is recommended for quick and easy burner mounting.

- If fuel insert is shipped inside burner housing, remove the fuel insert and insert nut and set aside in a protected area.
- Install service nut on the burner housing.
- Remove burner housing from the block/frame assembly. Use caution to prevent damage to the mounting gasket. The mounting gasket should be sandwiched between the burner housing and the nozzle body insert.
- Install block/frame assembly into furnace wall. Refer to next section for hot installation procedure for burner blocks.
- Pre-pipe quick-connect devices to the combustion oxygen, fuel and atomizing connections on the burner housing and burner fuel inserts.
- Confirm that cooling air or oxygen is available at the individual burner ports and control stations before installing burner housing. Block cooling wind is sufficient as a cooling air source.
- Confirm that mounting gasket is in good condition and that nozzle body insert is held firmly in place by the two spring pins.
- Confirm that service nut is installed on the housing (to prevent hot furnace gases from blowing out of the housing).
- Mount housing to block/frame studs.
- Install and snug the four corner mounting nuts and washers only.
- Connect the cooling oxygen/air source to the combustion oxygen connection on the burner housing and begin cooling flow.
- Install and snug the remaining mounting washers and nuts. Do not overtighten the mounting nuts.
- Apply an oxygen-compatible lubricant to the two O-rings on the fuel insert.
- Remove service nut from housing.
- Install the fuel insert into the housing.
 - Fuel oil burners: Push the insert into the housing until both O-rings are inside and the machined flange on the oil insert contacts the housing.
 - Fuel gas burners: The gas nozzle is designed to lock into the nozzle body insert. Push the insert into the housing until both O-rings are inside housing. Once gas nozzle contacts the nozzle body insert, wiggle the fuel gas insert while pushing forward at the same time. This should ensure that the nozzle has locked into the nozzle body insert. Unlike the fuel oil insert, there is no machined stop on the fuel gas insert.
 - If the fuel gas nozzle is not locked into the nozzle body insert, poor burner performance and higher emissions will result. The resulting improper flows generated could destroy the gas nozzle.
- Confirm that cooling oxygen or air is flowing. If not, remove fuel insert and establish cooling flow through housing.
- Thread the insert nut onto the housing until it bottoms out against the fuel insert. The insert nut can be used to push the fuel insert fully into the housing. Once the insert nut bottoms out, back the nut off 1/16 of a turn. It is not necessary for the insert nut to be tight.

- Connect fuel supply and atomizing medium (fuel oil firing) to the fuel insert.
- Burner installation is complete.
- Other system safeguards and approvals must be completed before burner can be lit. These safeguards include but are not limited to: furnace operating temperature at the burner location must exceed the ignition temperature of the fuel being used (for burners with no pilot) and oxygen/fuel control must be functional and characterized to provide the proper oxygen/fuel ratio to the burner.

Start-up instructions are specific to each application. Contact your MAXON representative for instructions for your particular application.

Hot installation procedure for AZS (Alumina/Zirconia/Silica blend) burner blocks

The following procedure has to be used to install AZS burner blocks without interrupting operations.

1. The block should be warmed (>212°F) for up to 4 hours and all moisture removed before starting installation.
2. Where the new block contacts older, hot materials, Fiberfrax paper should be used as a thermal buffer.
3. Remove the old block and clean the opening.
4. Insert the new block into the furnace.
5. Allow the new block to heat up to near ambient temperatures (usually about one half to three quarters of an hour).
6. Resume normal operations.

Hot installation procedure for Zirconia burner blocks



Prior to installing the block, be certain that the block will rest on a smooth, flat surface for the full length of the block once it is in place. The weight of the block is not to be supported or rested on the frame flange. (This will prevent putting stress on the block by having the weight supported at two points - the front and back.) During installation, the block should be supported for its entire length.

1. The block should be warmed to a temperature greater than 212°F and all moisture removed before starting installation.
2. Leave the firing end of the block exposed for one inch and have a strip of ceramic wool insulation covering the remaining length of the block.
3. Set the exposed end of the block into the hole for one hour. If the customer chooses to leave the housing connected to the block during installation, cooling air should be connected and blowing through the housing and block at all times.



NOTE: Any portion of the block that is exposed and outside the furnace wall after the block is in position should be wrapped with ceramic wool insulation and completely supported on a flat surface.

4. After one hour of preheat per step 3, remove the ceramic wool insulation strip and insert the remaining portion of the block into the opening.
5. Once the block is installed, it should be shimmed and sealed. If the block is not properly sealed, hot furnace gases can damage or destroy the frame.
6. The burner's piping must be supported independently to minimize additional stresses applied to the block.
7. Allow the new block to heat up to near ambient temperatures (approximately 1 hour) and then resume normal operations.

Start-up instructions

Instructions provided by the company or individual responsible for the manufacture and/or overall installation of a complete system incorporating MAXON burners take precedence over the installation and operating instructions provided by MAXON. If any of the instructions provided by MAXON are in conflict with local codes or regulations, please contact MAXON before initial start-up of equipment.



Read the combustion system manual carefully before initiating the start-up and adjustment procedure. Verify that all of the equipment associated with and necessary to the safe operation of the burner system has been installed correctly, that all pre-commissioning checks have been carried out successfully and that all safety-related aspects of the installation are properly addressed.

Initial adjustment and light-off should be undertaken only by a trained commissioning engineer.

First firing or restart after shut-down

During first start-up of the burner, and after every longer installation shut-down, the temperature rise shall be limited. Allow the burner to fire on low fire for some time to allow the parts to heat up slowly.

Checks during and after start-up

During and after start-up, check the integrity of the system. Check all bolted connections after first firing (first time on temperature) and retighten if necessary.

Pilot ignition

Before ignition of the pilot, adjust the oxygen to the minimum burner capacity. Pilot will not ignite if the oxygen flow is too high. Set pilot gas flow to the correct value before pilot ignition attempt.

Main burner ignition

Set correct gas flow for burner minimum capacity before attempt of main burner ignition.

After ignition of main burner, allow some time on minimum capacity to allow the burner parts to heat up slowly.

Burner adjustment and control

Oxygen-fuel burners require accurate control of both fuel and oxygen for optimum performance. Piping to individual burners should include control valves for both oxygen and fuel. In addition, flow meters for oxygen and fuel capable of local or remote readout are required for proper burner adjustment.

If required, flame sensing may be accomplished by UV scanner. Burner design can incorporate a UV scanner port suitable for supervision of both pilot and main flames. UV scanner, if used, should be kept as close to burner as feasible. Heat block, if used, may affect signal strength with some brands of UV scanners.



CAUTION: Oxygen should only be used with approved materials, properly cleaned pipe and equipment, and specially designed systems. Ordinary materials can be extremely flammable in the presence of oxygen and air enriched with oxygen.

Maintenance & inspection instructions

Safety requirements

Regular inspection, testing and recalibration of combustion equipment according to the installation manual is an integral part of its safety. Inspection activities and frequencies shall be carried out as specified in the installation manual.

Perform the following activities at least annually as part of a recommended preventative maintenance routine:

- Inspect burner internal parts for wear and oxidation.
- Inspect associated control instruments and devices for function with particular attention to all safety permissive switches.
- Perform leak tests on fuel shut-off valves according to any schedule established by the authority having jurisdiction.

Visual inspections

Regular visual inspection of all connections (oxygen and gas piping to the burner, bolting of the burner to the furnace) and burner flame size and aspect are essential for safe operation.

Spare parts

Keep local stock of spark ignitor if burner is equipped with pilot. It is not recommended to keep local stock of other burner parts. Consult installation manual for burner spare parts and system accessories.

Distributed by:



888.858.3647 | relevantsolutions.com