

OXY-THERM® Gas or Oil Burners

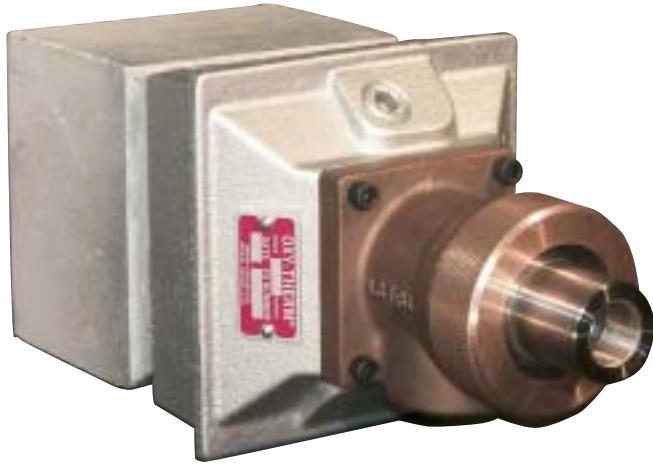

OXY-THERM® Gas Burner

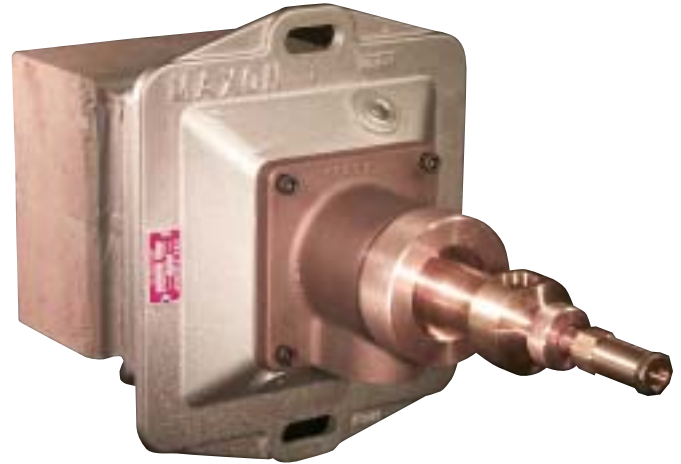

OXY-THERM® Oil Burner

- **Provide clean combustion with low NOx levels.** OXY-THERM® Burners use oxygen for the combustion reaction, removing atmospheric nitrogen as a source for NOx creation.
- **Burns any gaseous fuel,** including fuels that may be unstable using air for combustion.
- **Fuel oil capability ranges from light to heavy fuel oils.**
- **Quickly convert between gas and oil service** by changing the burner nozzle. Provides stand-by or alternate fuel capabilities.
- **Easy installation and maintenance.** OXY-THERM® Burner nozzles can be removed or changed during furnace operation, eliminating costly downtime.
- **Dramatically increase available heat by producing higher flame temperatures** from burning fuels with oxygen. OXY-THERM® Burners eliminate the need for costly combustion air preheaters, regenerators or recuperators.
- **Substantially reduce the size of exhaust gas handling equipment.** Oxygen-fuel firing can reduce flue gas volume by 75% or more.
- **Quickly change burner capacity** by simply replacing the burner nozzle.
- **Improve heat transfer,** leading to better uniformity, heat distribution and product quality.
- **Eliminate the need for water cooling** and related water piping and maintenance.
- **Simple, robust design** and high operational turndown provides application flexibility.

Gas OXY-THERM® manufactured under U.S. Patent #4690635,
 Canadian Patent #1260378, U.K. Patent #2192982,
 German Patent P3722446.8 and French Patent #8704742.
 Oil OXY-THERM® Burner manufactured under U.S. Patent #5092760.
 Additional patents pending in Canada, Europe, Japan, South Korea and Mexico.



CORPORATION

201 East 18th Street, P.O. Box 2068, Muncie, Indiana, 47307-0068. Phone: (765) 284-3304. FAX: 765-286-8394

OXY-THERM® Gas or Oil Burners

Principle of Operation

With OXY-THERM® Burners, oxygen for combustion enters the burner body, mixes with the fuel and exits the burner block.

For oil firing, oil enters through the nozzle, is atomized and combines with the combustion oxygen as it exits the burner block.

The ignited oxygen-fuel flame discharges through the refractory block.

Pilots are generally not required for oxygen-fuel applications, but are available through Maxon. Contact your Maxon representative about specific piloting questions.

Typical applications include converted regenerative-type furnaces and melters, unit melters, non-ferrous melting, hazardous waste incineration and special applications requiring high temperatures.

Flow control and shut-off valves (available from

Maxon) need to conform with the appropriate codes and standards for oxygen service.

Two refractory block materials are available for OXY-THERM® Burners. **AZS (Alumina/Zirconia/Silica) burner blocks** are to be used for gas firing only, and should be checked for compatibility with your process. **Zirconia burner blocks** may be used with gas firing and are required for oil firing due to the intensely radiant nature of the flame and high resultant flame temperatures.

Capacities

Gas OXY-THERM® Burners provide maximum outputs that range from 200 MBtu/hr (59 KW) to 11.0 MMBtu/hr (3.2 MW). Oil OXY-THERM® Burners provide maximum outputs that range from 3.1 MMBtu/hr (915 KW) to 19.9 MMBtu/hr (5.8 MW).

NOTE: In the Imperial System, "M" refers to 10³, "MM" refers to 10⁶.

**OXY-THERM®
Oil Burner**
(exploded view)

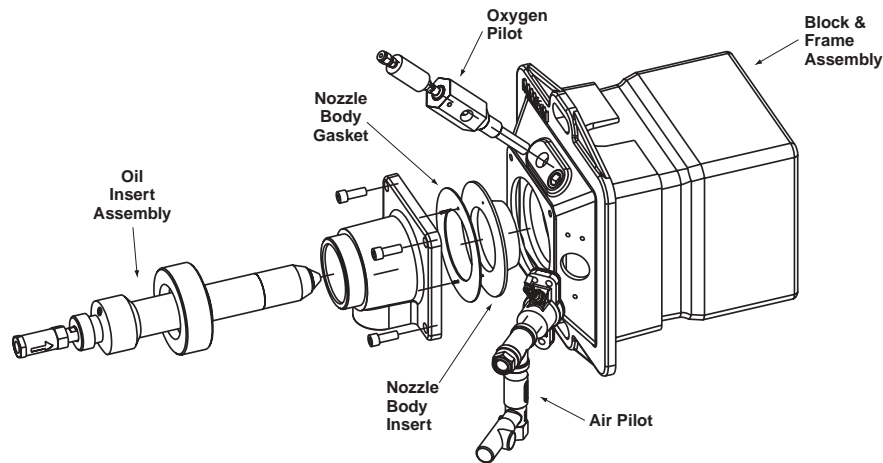

**OXY-THERM®
Gas Burner**
(exploded view)

