

# Series “SN” Sealed Nozzles

## with refractory tunnel block for sealed-port firing



- Improve higher temperature operating efficiency and atmosphere control by sealing out any secondary air introduction
- Stable, clean combustion of most fuels
- Economical, flexible method of heating processes
- Integral pilots and flame detection
- Compact flame geometry for easy integration in most furnaces

## Product description

Series "SN" Sealed Nozzles are tunnel-type, refractory block, closed-port burners for firing of air/gas premixtures without secondary air. They are designed to be installed into refractory, thin-wall, or soft-wall combustion chambers and fed by almost any air/gas premixing system.

The air/gas mixture manifold from your premixing system is threaded into the Series "SN" Sealed Nozzle assembly. This premixture is directed out through the nozzle body's main port into the stepped-tunnels of the refractory burner block.

A pilot port tunnel and a flame supervision port (not shown in sketch below) intersect the main tunnel directly in front of the nozzle body's main port. At this three-way tunnel intersection, the flame safeguard (flame rod or UV scanner) monitors the pilot flame and/or main burner flame.

Once the air/gas premixture is ignited by a separate mounted pilot and spark ignitor, the flame front progressively steps out through the burner block's tunnel. The steps within the tunnel help to provide positive flame retention of the burner flame at all firing rates.

- 1) Nozzle
- 2) Refractory cement seal
- 3) Burner block
- 4) Mounting frame
- 5) Air/gas premixture from mixing device

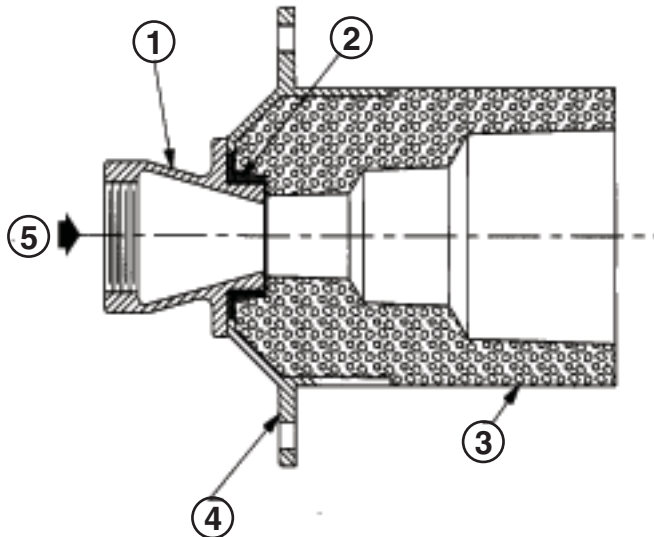

## Available Sealed Nozzle sizes

Series "SN" Sealed Nozzles (available in 3/4" through 1" sizes) consist of a threaded nozzle, cast iron frame and a refractory burner block. "SN" Sealed Nozzles do not include any provision for mounting a flame safeguard device.

Series "SNF" Sealed Nozzles (available in 1-1/4" through 3" sizes) are the same as "SN" Sealed Nozzles, but incorporate a flame safeguard port through which a flame rod or a UV scanner can be mounted.

## Typical applications

Sealed Nozzle Burners provide exceptional reliability with a large variety of gas fuels and waste gases. Its unique mixing pattern provides stable combustion and moderate emissions over a wide range of operation.

Sealed Nozzle Burners are typically used on furnaces, kilns, lehrs and other processes with temperatures up to 3000°F. With the ability to operate at a variety of gas/air ratios, the Sealed Nozzle Burner is useful anywhere atmosphere control is desirable.

- 1) Sealed Nozzle burner
- 2) Air/gas mixer
- 3) MICRO-RATIO® air/gas control valve
- 4) Combustion air blower
- 5) MAXON safety pipe train including MAXON shut-off valves

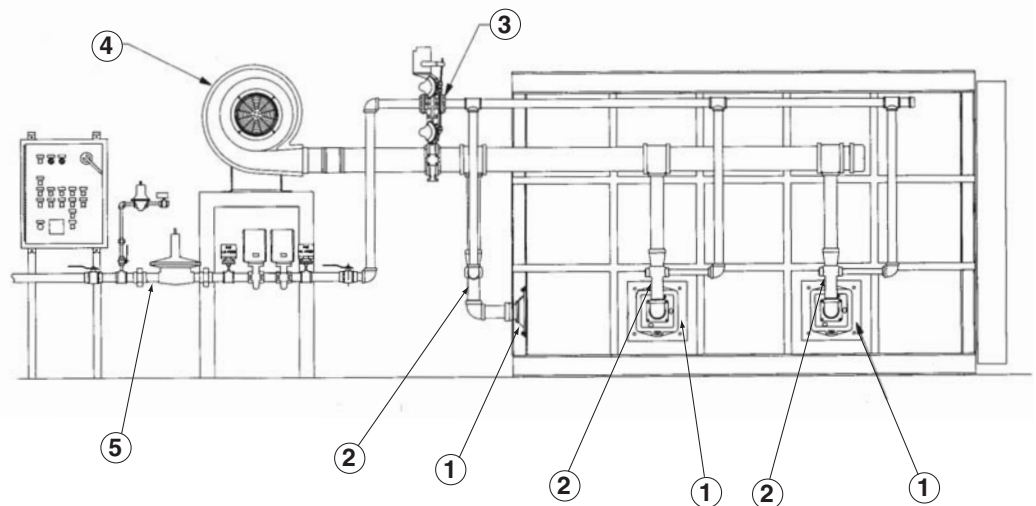

Shown: A typical car bottom furnace

## Dimensions and weights

- 1) Nozzle body
- 2) Pilot assembly
- 3) Block frame
- 4) Refractory block

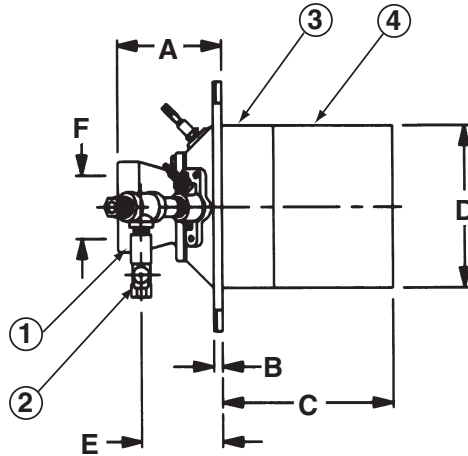

Dimensions in inches unless stated otherwise							
Burner size	A	B	C	D Ø	E	F [1]	Weight lbs
3/4"-5, -7	2.44	.31	7.5	5	---	3/4"	31
1"-9						1"	31
1-1/4"-12, -14						1-1/4"	31
1-1/2"-16, -18	3.31	.38	9	7.5	3.94	1-1/2"	58
2"-20	3.44					2"	58
2"-24	4.19					68	
2-1/2"-27	4.69					2-1/2"	68
3"-33	5.75	.5	9.5	9	3.68	3"	79

[1] NPT or ISO threads available

Read "Specifications of Sealed Nozzle burners" for correct and complete information on Sealed Nozzle burners.

Distributed by:



888.858.3647 | relevantsolutions.com