

STICKTITE™ & PILOTPAK™

Flame retention nozzles



- For open-port firing or open environment firing
- Provides positive flame retention and stable clean burning, while directing the torch-shaped flame onto products or through open ports to your heat processes
- Economical, flexible method of heating processes
- Wide variety of sizes and configurations for optimal selection and sizing
- Integral pilot on PILOTPAK™ nozzles provides simplified integration of pilot, ignition and flame sensing

Distributed by:



888.858.3647 | relevantsolutions.com

W W W . M A X O N C O R P . C O M

COMBUSTION SYSTEMS FOR INDUSTRY

Maxon reserves the right to alter specifications and data without prior notice.
© 2010 Copyright Maxon Corporation. All rights reserved.

MAXON
A Honeywell Company

Product description

STICKTITE™ and PILOTPAK™ nozzles are designed for direct-fired air heating and/or open-port firing into a furnace, duct, or immersion tube. These nozzles are also useful for applying flames directly to products in processes such as flame laminating plastics, soldering, paint removal, rail car heating and hair removal from processed livestock. The single torch-like flame creates a venturi effect that pulls secondary air in around the burner nozzle and provides necessary cooling of the cast metal nozzle.

Principle of operation

The burner nozzle is threaded onto the feed manifold from an air/fuel premixing device. This premixture is directed out through the nozzle's main port. A small portion of the premixture is channeled out through the smaller ignitor ports that surround the large main port. The gas/air mixture is ignited by a spark ignitor or separate pilot assembly.

The turbulence created on the face of the nozzle provides positive flame retention of the torch flame emitted out of the main port. The flames from the tiny ignitor ports are protected from outside air turbulences and surround the base of the main flame to continually ignite the premixture being forced out of the nozzle by the mixture pressure from your mixing device.

- 1) Ignitor ports
- 2) Main port
- 3) Air/gas premixture from mixing device
- 4) Spark ignitor port (for direct spark versions)

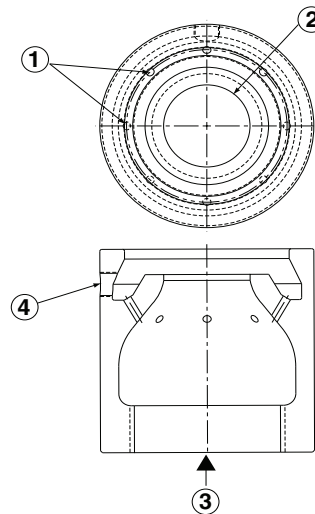

Available versions

- STICKTITE™ nozzles are available in three versions for a variety of temperature and application conditions. The STICKTITE™ may also be equipped with a direct spark ignitor, a mounting and support bracket or with loose pilot assemblies.
 - HD nozzles are cast iron burners with eight ignitor ports for low temperature applications (< 1000°F) for firing applications with slight draft (less than 0.5"wc). HD nozzles should also be used for any application where differential mixture pressure to the nozzle exceeds 7"wc.
 - BP nozzles are cast iron burners with four ignitor ports for low temperature applications (< 1000°F) with neutral to slightly positive pressure (up to 0.25"wc). Do not exceed over 7"wc total differential mixture pressure with BP nozzles.
 - HV nozzles are burners with a cast iron body and stainless steel retention ring. They are used for higher temperature applications up to 2400°F or where the nozzle might be exposed to high radiant heat and/or sting-out from the firing port. The HV nozzles can be used in applications with slight draft (less than 0.5"wc) or with slight positive pressure (up to 0.25"wc). HV nozzles can also be used for any application where differential mixture pressure to the nozzle exceeds 7"wc.
- PILOTPAK™ nozzles integrate the piloting and flame sensing provisions directly on to the nozzle for simple integration into a full heating system. PILOTPAK™ nozzles may also use optional nozzle support brackets. The PILOTPAK™ nozzles are suitable for firing applications with a slight draft (no less than -0.5"wc). The PILOTPAK™ nozzle is only suitable for applications in which normally an HD nozzle would be used.

Applications

STICKTITE™ and PILOTPAK™ nozzles provide a cost effective means of heating a wide variety of processes and products. These nozzles have been successfully used for:

- Ladle preheating
- Solution tank heating
- Fryer heating
- Flame treating plastics and laminates
- Oven and dryer heating
- Crucible heating
- Glass day tanks
- Transmission gas heaters
- Coffee roasters
- Perlite expansion

- 1) PILOTPAK™ Nozzle
- 2) Pilot gas orifice
- 3) Ignitor
- 4) Flame detector

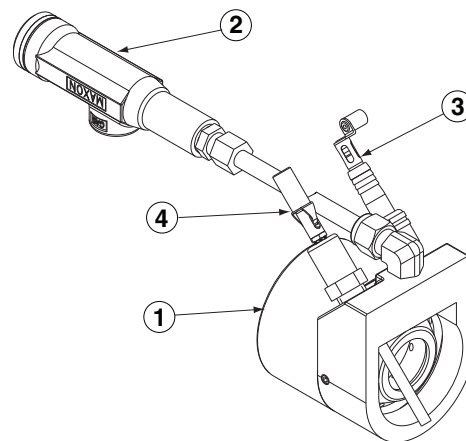

Dimensions and weights

- 1) Spark ignitor (direct spark ignited versions only)
- 2) Ignitor ports
- 3) Main port

HD and BP STICKTITE™ nozzles

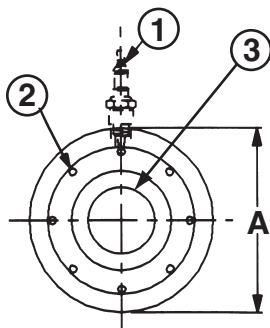

HV STICKTITE™ nozzles

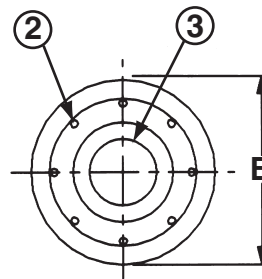

Dimensions in inches unless stated otherwise

Nozzle size	Main port diameter	Discharge area (in ²)	A	B	Weights lbs
1/2"-5	5/16	0.077	1.44	---	0.5
3/4"-6	3/8	0.110	1.56	---	0.5
3/4"-7	7/16	0.150		---	0.5
1"-8	1/2	0.196	2	---	1
1"-9	9/16	0.248		---	1
1-1/4"-10	21/32	0.338	2.38	---	2
1-1/4"-12	3/4	0.442		---	2
1-1/4"-14	7/8	0.601		---	2
1-1/2"-16	1	0.785	2.69	---	3
1-1/2"-18	1-1/8	0.994		---	3
2"-18			3.25	---	4
2"-21	1-5/16	1.35		---	4
2"-24	1-1/2	1.77		3.25	4
2-1/2"-27	1-11/16	2.24	3.88	3.88	6
3"-30	1-7/8	2.76	4.56	4.56	10
4"-34	2-1/8	3.55	5.88	5.88	17
4"-41	2-9/16	5.16			16
5"-50	3-1/8	7.67	6.62	7.12	26
6"-60	3-3/4	11.04	8.5	8.25	50
8"-84	5-1/4	21.65	---	10.75	81
8"-88	5-1/2	23.76	11.38	---	110

Typical emissions

STICKTITE™ and PILOTPAK™ nozzles utilize full premix combustion. This suppresses the formation of prompt NOx. In many applications, this will provide lower levels of NOx. CO will be dependent on the application and firing environment.

Read "Specifications of STICKTITE™ and PILOTPAK™ nozzles" for correct and complete information on STICKTITE™ and PILOTPAK™ nozzles.