

Installation Instructions

General Instructions

Important: Do not discard packing material until all loose items are accounted for.

To prevent damage in transit, the spark ignitor, mounting ring, flame rod and connecting linkage components may be packed separately and shipped loose with your new Maxon TUBE-O-FLAME® Burner.

The burner itself is normally only a part of your complete combustion system. Additional pipe train accessories and control components will be required for a complete system installation. The sketch below shows a typical gas train as might be used with a Series "67" TUBE-O-FLAME® gas fired burner.

Piping Layout as sometimes required by insurance and standards groups

Block and Bleed gas train arrangement illustrated with Series "67" TUBE-O-FLAME® Burner

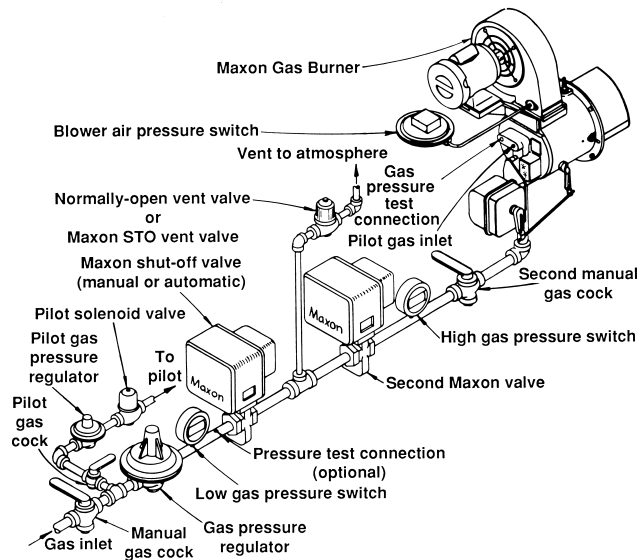

TUBE-O-FLAME® Burner provides the air supply (unless it is an LB version, which requires a separate combustion air blower). It also serves as a fuel flow control and fuel/air mixing device.

Burner should not be exposed to direct radiant heat or positioned where it might draw in inert gases. If such conditions exist, consider filters, relocation, and/or use of the LB version and external air supply.

Electrical service must match the voltage, phase, and cycle of all electrical system components and be compatible with burner nameplate ratings. Insure that all normal control safeguards are satisfied. Combustion air blower should continue to run after shutdown to allow burner to cool.

Gas supply piping must be large enough to maintain the required fuel pressures cataloged for the particular burner size used with burner operating at full rated capacity.

Anything more than minimal distance or piping turns may necessitate oversizing piping runs to keep pressure drops within acceptable ranges.

Inlet pipe leading to any burner should be at least four pipe diameters in length. If multiple burners are fed from a single gas train, care should be taken to minimize pressure drop and give maximum uniformity.

Clean fuel lines are essential to prevent blockage of pipe train components or burner gas ports.

Main Shut-Off Cock should be upstream of both the main gas regulator and pilot line take-off. Use it to shut off fuel to both pilot and main burner during shut-down periods of more than a few hours.

The fuel throttling valve contained within a Maxon burner is not intended for tight shut-off.

Main gas regulator is essential to maintain a uniform system supply pressure. If one pipe train supplies multiple burners, provide a separate regulator in the branch leading to each burner system.

Size the regulator for full system capacity at the required pressure, carefully considering pipe train losses. Follow the instructions attached to the regulator during installation and be sure to remove any shipping pin or block.

Pilot take-off should be upstream of the main gas regulator, but downstream of the main gas cock. It should normally include its own pilot gas regulator, a solenoid valve and shut-off cock. A pilot adjustable orifice at the pilot inlet simplifies adjustment.

Pilot piping must be large enough to provide for the full flow and pressures shown in the catalog for your particular burner size.

The 3/8" pilot connection of the Series "67" TUBE-O-FLAME® Burner is adequate for the pilot gas flows shown, but care must be taken to assure that the required gas pressure is available at pilot inlet. To avoid excessive drop through solenoid and upstream valves and cocks, follow these guidelines:

Burner Model	Suggested Pipe Size	Pilot Natural Gas Flow (cfh)
6-08	3/8"	55
8-15	3/8"	80
10-25	1/2"	145
10-30	1/2"	180
12-38	1/2"	195
14-50	3/4"	300

Installation Instructions

Fuel Shut-Off Valves (when properly connected to a control system) shut the fuel supply off when a hazardous operating condition is sensed. Manual reset valves require operator attendance each time the system is started up (or restarted after a trip-out). Motorized shut-off valves permit automatic start or restart when used with an appropriate control system.

Test connections are essential for burner adjustment. They should be provided immediately downstream of the regulator and are included in the burner itself. **Test connections must be plugged except when readings are being taken.**

Exhaust stack dampers are necessary to the proper operation of an immersion tube burner system. They should be lockable, suitable for 1000°F and designed to prevent full stack closure.

Horizontal mounting is preferred. Most manufacturers' control motors require operating shaft in a horizontal plane.

Burner mounting requires four studs and a flat mounting surface perfectly centered on the firing tube. Burner can be mounted directly on tank wall using four welded studs, but the more common practice utilizes an optional mounting ring (complete with studs) welded to tank wall, end of tube, or other mounting surface. If the application calls for positioning the burner in other than its normal upright position, be sure to align studs appropriately.

After placing burner in position over studs, add lock washers and nuts, then draw up all four hand-tight only. Check that burner is seated evenly around the flange, filling any gaps to prevent air leakage, then tighten all nuts firmly.

For proper performance of any burner, air inlet and motor should be surrounded by clean, fresh, cool air.

Burner and pipe manifold support may be required to support weight of the burner and connected pipe train components. Air control motors, in particular, require additional support. Maxon connecting base and linkage assemblies are designed to position the control motors to work with the burner, **not** to support their weight.

The Series "67" TUBE-O-FLAME® Burner may require external auxiliary support provided by the user. The support configuration may be similar to the leg support or knee bracket support illustrated.

Additional burner support may be required in conjunction with a stiffener plate when mounting TUBE-O-FLAME® Burner (weighing 100-350 pounds) onto tube or thin tank walls.

Suggested supporting arrangements

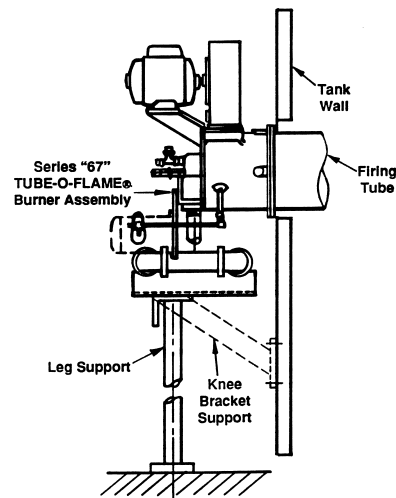

Exhaust Considerations

Immersion tubes are usually vented to the outdoors, except for those in highly ventilated areas such as a plating room with continuous high volume exhaust. An exhaust fan may be required if the building is under negative pressure. Exhaust is normally diluted to avoid the need for high temperature fans, but adequate make-up air must be available.

This diluting can be done with an open tee installed in a vertical run (or in a horizontal run with the open end down), but such a system mixes slowly.

An adjustable hood (shown in sketch below) offers much better performance. In all cases, care must be taken that all products of combustion are exhausted from the building.

An exhaust stack damper must be used, suitable for 1000°F, and designed to prevent full stack closure.

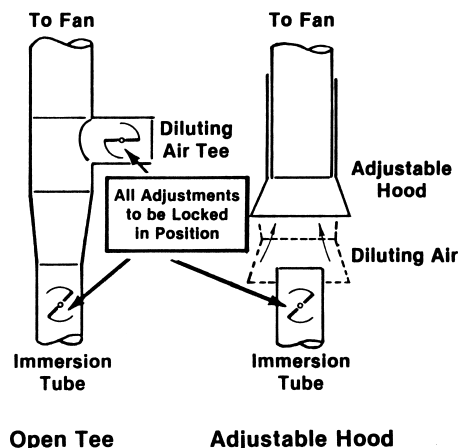

CORPORATION
MUNCIE, INDIANA, USA

Maxon practices a policy of continuous product improvement. It reserves the right to alter specifications without prior notice.

INDUSTRIAL COMBUSTION EQUIPMENT AND VALVES

Installation Instructions

Protective covers for burner should be added in the field if exposure to dripping condensate, splashing flux, exhaust steam, etc. is unavoidable.

Sketches below illustrate some possible arrangements. Any cover used should be removable to provide access to burner and should not interfere with control linkage motion or observation port viewing.

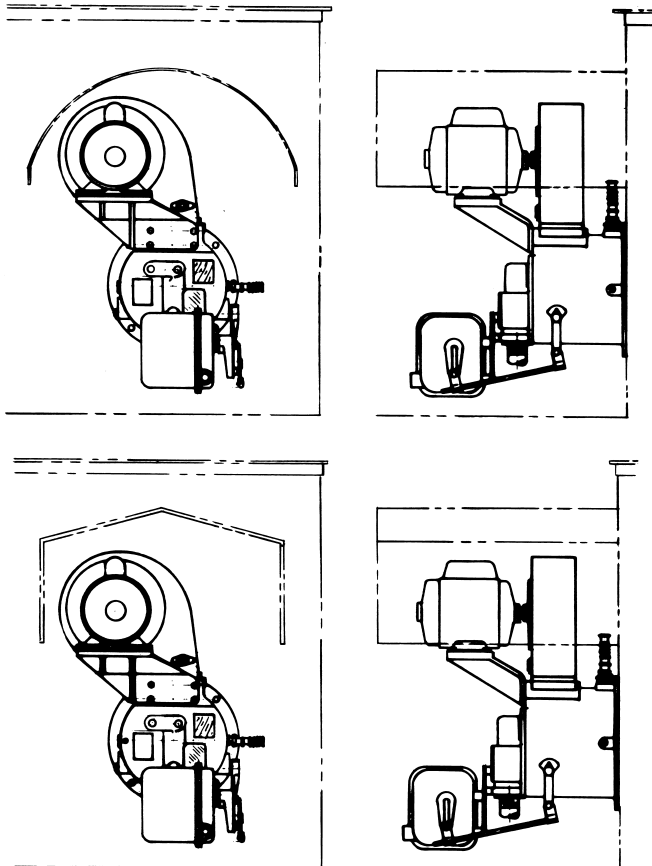

WARNING: Welding of burner flange to a stiffener plate or firing tube may cause warpage of burner flange and require additional seal material to prevent leakage.

Flame sensing can be accomplished by either flame rod or UV scanner. When UV scanner is used, it should be kept as close to burner as feasible. **Do not use cooling air to scanner port:** sighting is through gas cavity. Heat block, if used, may affect signal strength with some brands of scanners.

Field conversion from a flame rod version to a UV scanner version and vice versa may require additional parts in the burner. Contact Maxon for requirements.

Alternate fuels may require correction of supply pressures.

If TUBE-O-FLAME® Burner is equipped with **Maxon Hi/Lo Control Motor**, low-fire start wiring can be accomplished as shown in the sketch below.

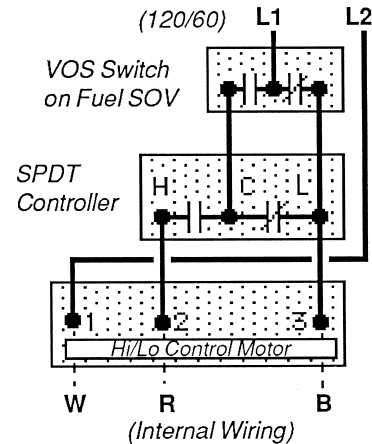

Maxon assumes no responsibility for the use or misuse of the layouts shown. Specific piping and wiring diagrams should always be submitted to the appropriate agencies for approval on each application.

Multi-burner installations require special considerations if supplied by a common pipe train and/or air supply. **Air and Gas Balancing Valves** should be used for improved heating uniformity; **Gas Swing-Check Valves** should be installed as close as possible to each burner inlet for dependable lightoff (gas manifold may otherwise act as a reservoir, preventing lightoff during trial-for-ignition period).

Control system's circuitry must not allow main Fuel Shut-Off Valve to be opened unless combustion air is on, and must de-energize valve upon loss of combustion air pressure, along with the other usual system interlocks. Motor starter is to be interlocked with valve, whether or not a combustion air pressure switch is used.

Start-Up Instructions

Read complete instructions before proceeding, and familiarize yourself with all the system's equipment components. Verify that your equipment has been installed in accordance with the original manufacturer's current instructions.

CAUTION: Initial adjustment and light-off should be undertaken only by trained and experienced personnel familiar with combustion systems, with control/safety circuitry, and with knowledge of the overall installation. Instructions provided by the company and/or individuals responsible for the manufacture and/or overall installation of complete system incorporating Maxon burners take precedence over these provided by Maxon. If Maxon instructions conflict with any codes or regulations, contact Maxon Corporation before attempting start-up.

For initial TUBE-O-FLAME® Burner start-up:

1. **Close all burner fuel valves and cocks.** Make preliminary adjustments to fuel gas regulators. Remove pilot and main gas regulators' adjusting screw covers. Turn adjusting screw down (clockwise) to approximately mid-position. Close pilot gas adjustable orifice screw by turning in clockwise until it stops. (Do not over-tighten.) Then back out the adjustable orifice (counter-clockwise) approximately 2-3 turns.
 2. **Check all electric circuitry.** Verify that all control devices and interlocks are operable and functioning within their respective settings/ranges. Be sure all air and gas manifolds are tight and that test ports are plugged if not being used.
 3. **Check that the immersion tube stack damper is properly positioned** and locked into operating position.
 4. **Disconnect the automatic control motor's linkage** from your TUBE-O-FLAME® Burner's operating crank arm by loosening the control motor's connecting rod from the burner's toggle linkage.
5. **Start all system-related fans and blowers.** Check for proper motor rotation and impeller direction. Verify that all control interlocks are working. Allow air handling equipment to run for adequate purge of your manifolds and immersion tubes. With main gas shut off, manually advance TUBE-O-FLAME® Burner's operating crank to "high fire" position so that air only flows through burner and firing tube.

CAUTION: Do not by-pass control panel timers typically controlling sequential operations.

Series "67" TUBE-O-FLAME® Burners

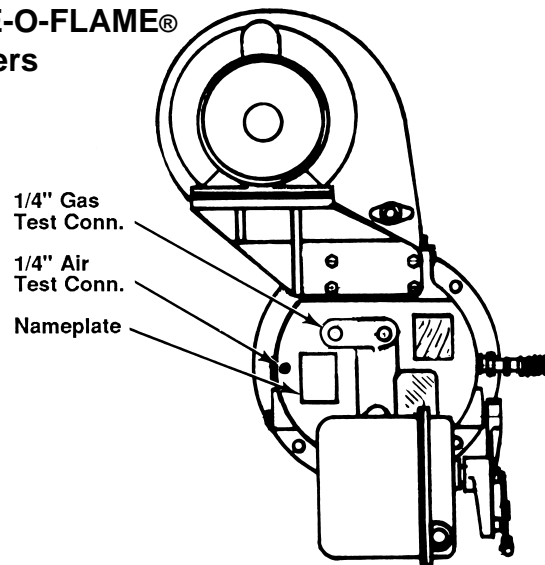

6. **Determine static condition of tube** (draft or suction) and verify differential air pressure at burner backplate air test port.
Measure your **air** pressure reading with manometer connected between the burner's **air** pressure test port and atmosphere with the burner at "high fire" position, fuel valves closed, and all air handling systems running.



Maxon practices a policy of continuous product improvement. It reserves the right to alter specifications without prior notice.

CORPORATION
MUNCIE, INDIANA, USA

INDUSTRIAL COMBUSTION EQUIPMENT AND VALVES

Start-Up Instructions

Record air test port reading. Chart below shows normal balanced tube static condition readings.

Burner Model	6-08	8-15	10-25	10-30 12-38	14-50
Air Pressure ("wc)	3.0	2.0	3.0	5.0	5.0

If your reading exceeds these normal readings, you have a back pressure in your tube.

If your readings are lower than the normal balanced readings, you have an exhaust suction in your tube.

Excessive suction can cause chugging and implies hot combustion products are being drawn out of the tube too fast, reducing thermal transfer efficiency. High tube suction also may affect differential gas pressure settings. Too high of a suction may lower inlet gas pressures so that low gas pressure switches cannot be adjusted.

Excessive back pressure can cause smoke and may restrict firing capacity of burner.

NOTE: The differential air pressure setting determines the burner's capacity and performance capabilities.

- Adjust exhaust fan and/or stack damper** to create burner air pressure test port readings as close as possible to those shown for normal balanced conditions to maximize system's thermal transfer efficiency.

NOTICE: Burner performance can be drastically affected by tube configuration and static conditions within tube created by exhaust fans and dampers in exhaust stack.

- Determine the required differential gas pressure** using this differential air pressure reading obtained from step 6. High fire pressures are provided in Maxon product line catalog literature and/or read data stamped into burner nameplate.
- Verify that spark ignitor is properly positioned** and lines up with the appropriate dimensions required for your specific burner. (Refer to appropriate Maxon catalog specification table.) Check that spark ignitor arcs at the end of your properly positioned ignitor.
- Return burner control valve/crank to low fire position** when purge of system is complete.

- Open main and pilot gas cocks**, then attempt spark ignition to light pilot while slowly turning pilot gas regulator clockwise and/or adjustable orifice screw counter-clockwise to increase fuel flow. Repeat procedure as necessary until pilot ignites, as air might have to be bled out of fuel supply lines before reliable pilot flame is established. Pilot gas regulator should normally be set for as low a pressure as possible, using fuller opening of pilot gas adjustable orifice (if used).
- After ignition, adjust pilot flame** for good stable flame shape. A rule of thumb is that any pilot over a tennis ball size is probably too large. This assumes you have visual access to the pilot flame. If this is not possible, then adjust pilot to give the strongest and most stable flame signal through your flame safety circuit. This signal strength can be read with a micro-amp meter. The signal strength (or range) will be determined by the specific type of flame safeguard instrument you have with your burner system.
- Re-check pilot ignition** by closing pilot gas cock or otherwise causing pilot outage. Re-light and refine pilot gas adjustment as necessary to get ignition within a second or two. The flame safeguard relays should now power your main fuel Shut-Off Valve(s).

CAUTION: After completing steps above, re-check all interlocking safety components and circuitry to prove that they are properly installed, correctly set, and fully operational. If in doubt, shut the system down, close pilot cock and contact responsible individual before proceeding further.

- Establish main flame.** With burner at low fire position, back out main gas pressure regulator adjusting screw (counter-clockwise) to get lowest outlet pressure possible. Open all manual fuel shut-off valves (automatic fuel shut-off valve should already be open) so gas flows to burner inlet. There should be little, if any, change in flame appearance. **Turn main regulator adjusting screw** in (clockwise) to obtain outlet pressure of about 4"-6" wc higher than combustion chamber pressure (2"-4" wc for propane, considerably higher for some LB versions). Main flame should now appear larger than pilot-only flame.

Start-Up Instructions

15. **Establish high fire setting** by slowly moving burner crank toward high fire position while observing gas pressure at burner gas test connection. Refine main gas regulator adjustment as necessary to provide correct differential gas pressure at high fire. If pressure cannot be adjusted low enough, a different regulator or regulator spring may be necessary, or a limiting orifice valve (such as Maxon's Series "BV") should be added. Do not, however, exceed 4" wc pressure drop between regulator outlet and burner inlet.

CAUTION: If burner(s) go out, close shut-off valve or shut main gas cock at once. Return to minimum setting, re-light pilots if necessary, then turn main gas on again. Check carefully that every burner is lit before proceeding.

Cycle burner from minimum to maximum and refine adjustment, if necessary.

For operation with interrupted pilot (as recommended), shut off pilots and cycle burner from minimum to maximum and back several times to verify the flame is maintained.

16. **When burner performance is satisfactory** and stable throughout the firing range, reconnect linkage to control motor.

Control linkage travel must be such that burner crank is moved throughout its complete travel, or cataloged capacities and turndowns will not be achieved.

If less than full-rated burner capacity is required, linkage can be adjusted to limit maximum output. **With interrupted pilot**, it may be necessary to set control for somewhat higher than minimum burner setting to permit hold-in of flame detection system without pilot.

CAUTION: Internal drive mechanism within the control motor may be damaged if linkage is adjusted so as to cause binding with burner in high or low fire position.

17. **Re-check differential gas pressure** with unit at operating temperature. Refine high fire setting if necessary, considering differential pressure, flame length, and appearance. Dust or contaminants in the air stream may affect flame appearance.

18. **Plug all test connections not in use to avoid dangerous fuel leakage.** Replace equipment cover caps and tighten linkage screws.

19. **Check out overall system operation** by cycling through light-off at minimum, interrupting pilot, and allowing temperature control system to cycle burner from minimum to maximum and return.

NOTE: Typical gas firing control sequence for Maxon burner is provided only as a guide. Instructions provided by complete system manufacturer incorporating Maxon burners take precedence.

For gas firing Series "67" TUBE-O-FLAME® Burner

Light-off:

1. Close cocks, shut-off valve(s)
2. Verify burner at low fire
3. Start recirculating/exhaust fans
4. Start burner blower
5. Purge at least 4 air changes
6. Open pilot & main gas cocks

Shut-down:

1. Close main & pilot gas cocks
2. Keep combustion air blower running after shut-down long enough to allow burner to cool

Recheck all safety system interlocks for proper setting and operation.

WARNING: Test every UV installation for dangerous spark excitation from ignitors and other possible sources of direct or reflected UV radiation. Use only gas-tight scanner connections.

20. **Before system is placed into full service, instruct operator personnel** on proper start-up operation with shut-down of system, establishing written instructions for their future reference.

Distributed by:



888.858.3647 | relevantsolutions.com



Maxon practices a policy of continuous product improvement. It reserves the right to alter specifications without prior notice.

CORPORATION
MUNCIE, INDIANA, USA

INDUSTRIAL COMBUSTION EQUIPMENT AND VALVES