

## Burner Selection Criteria

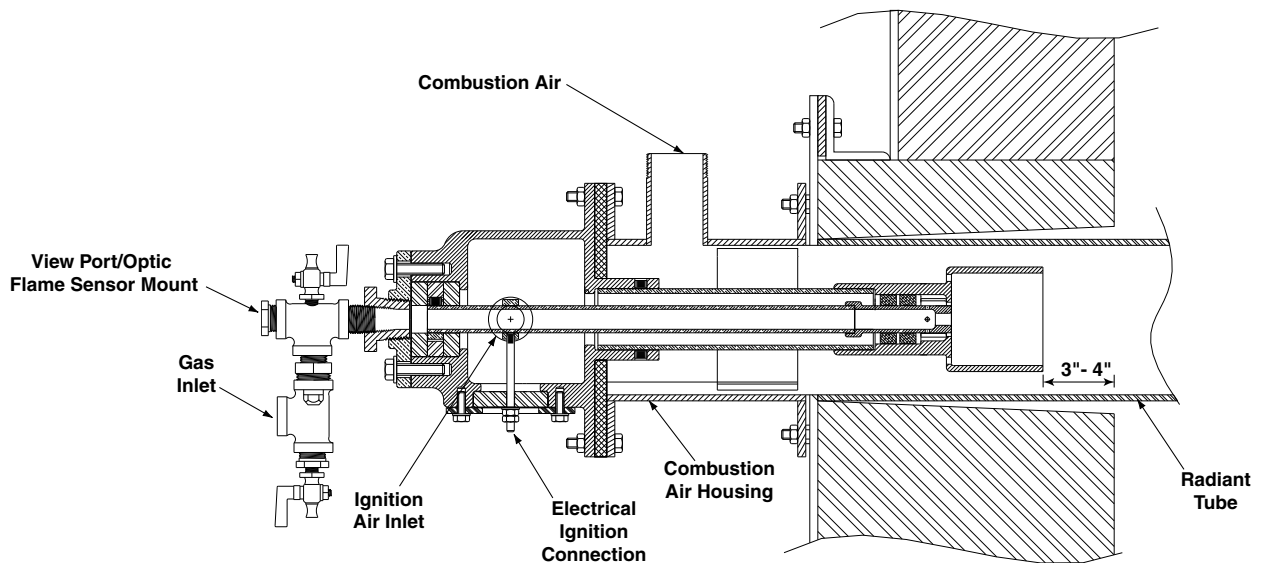

### Burner Selection

The UNI-RAD Burner can be used with various radiant tube sizes, tube configurations, heat inputs, etc. The following information should be supplied to assist Maxon in matching the correctly sized UNI-RAD Burner to your specific application:

1. Radiant tube inside and outside diameters
2. Radiant tube configuration
3. Furnace or process temperature
4. Radiant tube length
5. Radiant tube material
6. Method of mounting (standard flange, packing gland, etc.)
7. Furnace wall thickness (see page 4800-S-1 for mounting instructions)
8. Requirement for heat recuperation (if used)

### Typical Burner Firing Rates

Housing Size (inches)	Natural Gas Flow (CFH) and Btu/hr Capacity x 1000 Btu/hr	Combustion Air CFM
4"	151	28
4.5"	170	31
5"	188	35
6"	226	41
7"	264	48
8"	302	55

**Note:** Burner firing rate is based on:

1. 1000 Btu/CF Natural Gas
2. 120" total "U" tube length within chamber
3. 2% excess oxygen and 0% combustibles
4. 100 Btu/sq.in. of tube surface area

The table at left gives typical maximum capacities for the conditions shown. The UNI-RAD Burner has been used with firing rates ranging from 80,000 Btu/hr to 700,000 Btu/hr, depending upon tube length and diameter.

### Radiant Tube Life

Competitive burner systems stress the fuel savings obtained by the use of combustion air preheated to 800° to 1000° from waste heat energy. The fact that preheated air produces much higher flame temperatures, and consequently decreases furnace alloy life is generally ignored. The UNI-RAD system overcomes this problem through the use of pulse firing and has consistently shown increases in the furnace alloy life while saving fuel. An extensive number of UNI-RAD Burner users have increased their radiant tube life by as much as 300%.

UNI-RAD Burners have also successfully been applied to silicon carbide tubes. These tubes can handle higher operating temperatures than most alloy tubes, and allows for increased heat flux.

### Construction

The UNI-RAD Burner is constructed of cast iron and carbon steel with internal components constructed of stainless steel. The air inlet tube length must be specified when ordering to provide for differences in the furnace wall thickness.

## Burner Selection Criteria

### Piping

The gas and air piping for the UNI-RAD Burner is simple and direct. As shown in the piping schematic below, each UNI-RAD Burner uses one fuel gas line, one primary ignition air line, and one main combustion air line.

### Gas Metering

A custom drilled gas spud orifice on each burner sets the desired capacity. Typical gas pressure requirements at the burner range from 8" – 24" w.c. depending upon customer requirements.

### Air Metering

Combustion air flow is metered with a Limiting Orifice Valve (LOV) located prior to the inlet of the recuperator. A minimum of supply air pressure of 10" w.c. at the inlet to the recuperator is usually required. Higher pressures may be necessary, depending upon burner capacity, or how the recuperator is sized.

Primary ignition air is usually less than 7% of total air to the burner. The custom drilled air orifice in the ignition air pipe assembly sets the value. An LOV is sometimes used as a trim device to field optimize the burner ignition. The primary air is never throttled. It is kept on at all times.

**CAUTION: If main air ball valve is inadvertently closed, raw gas may be delivered to the tube, possibly creating an explosive condition.**

### Conclusion

The UNI-RAD Burner system has been successfully applied to a variety of furnaces. Its success is due not only to the quality of our equipment, but also to a careful evaluation of each application. We work with our customers to assure that every aspect of their combustion system is designed for optimum performance. Please contact your local Maxon representative for assistance.

### Typical Piping Schematic (Four Burners)

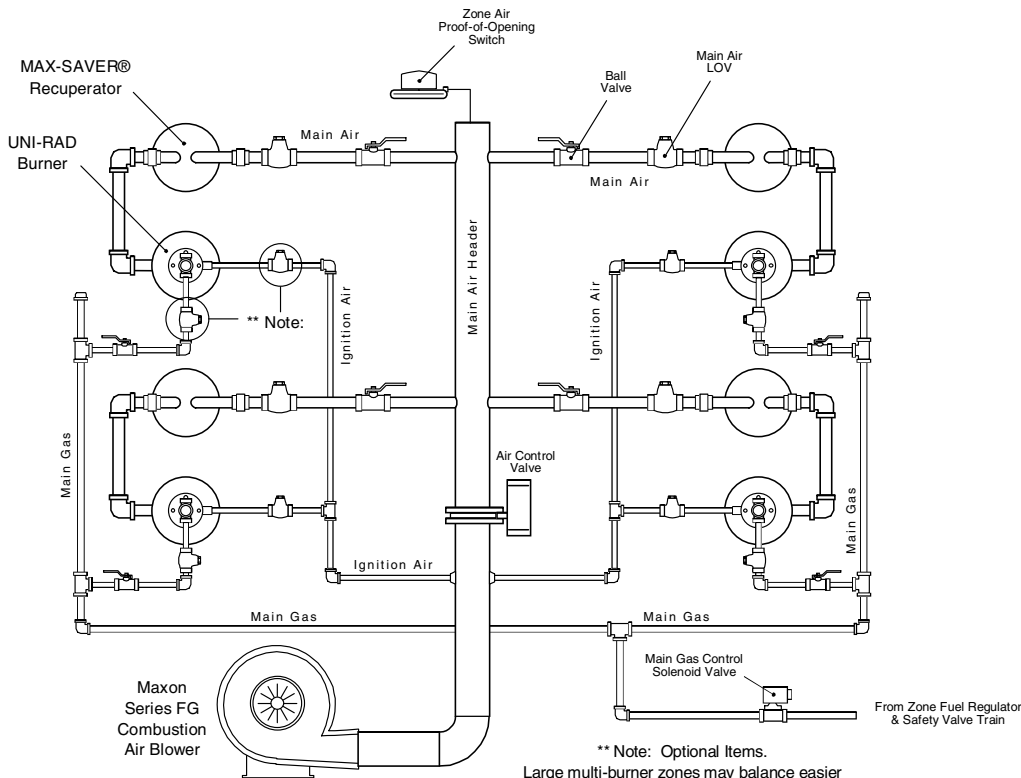

## MAX-SAVER® U-Shaped In-Situ Recuperator

The Maxon UNI-RAD Burner System consists of two major components:

- UNI-RAD Direct Spark Ignited Burner
- MAX-SAVER® In-Situ Recuperator

When these features are combined, they provide the following advantages over existing systems:

- Fuel savings ranging from 25% to 50% over non-recuperative systems
- Increased alloy life
- Improved furnace temperature uniformity
- Improved production quality
- Long recuperator life

### Typical Burner / Recuperator Layout

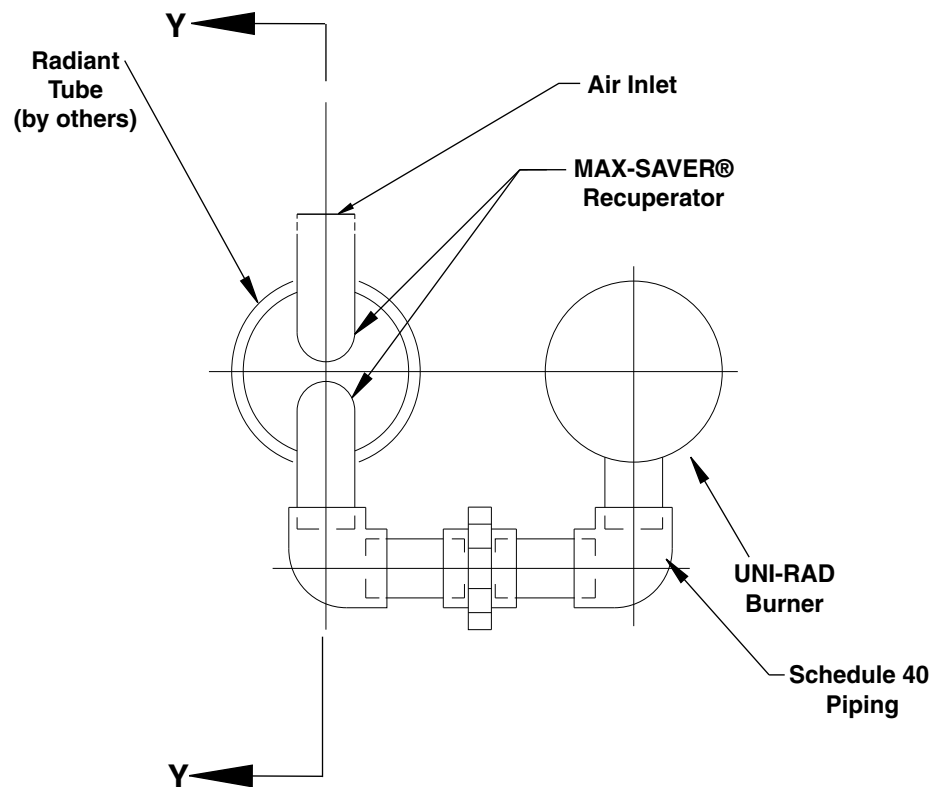

Section Y-Y shown on page 4806

# MAX-SAVER<sup>®</sup> U-Shaped In-Situ Recuperator

## Section View Y-Y

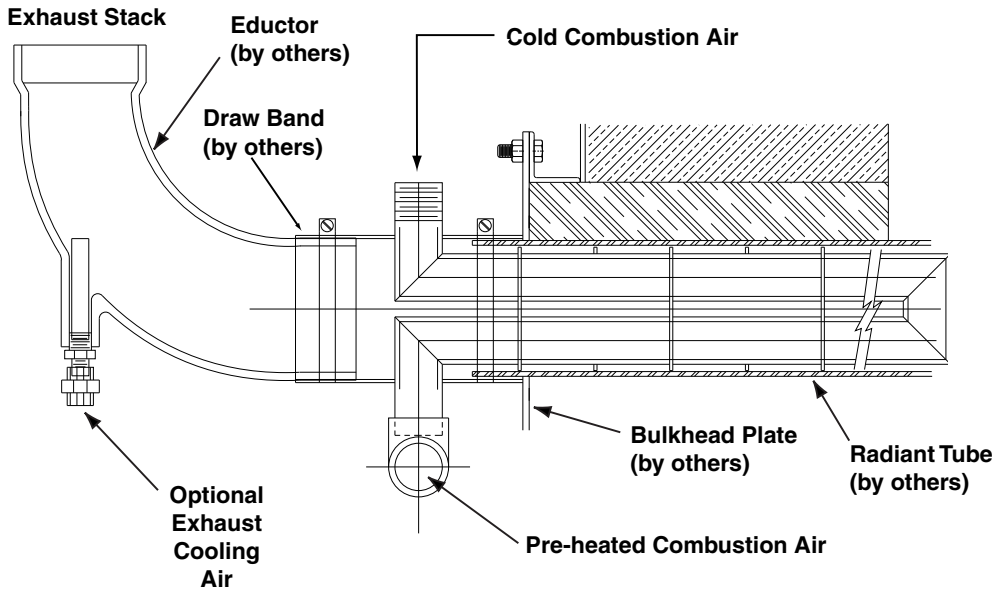

## Draw Bands (supplied by customer)

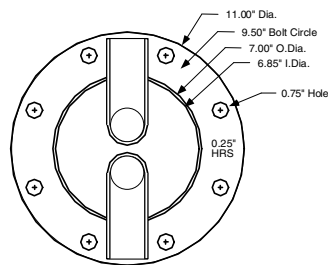

Section A - A

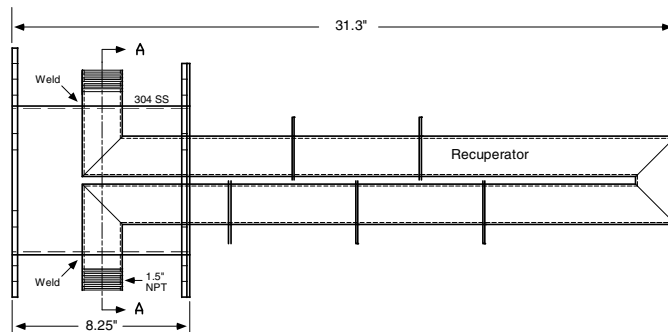

# Dimensions (in inches)

## UNI-RAD Burners - used with metal tubes

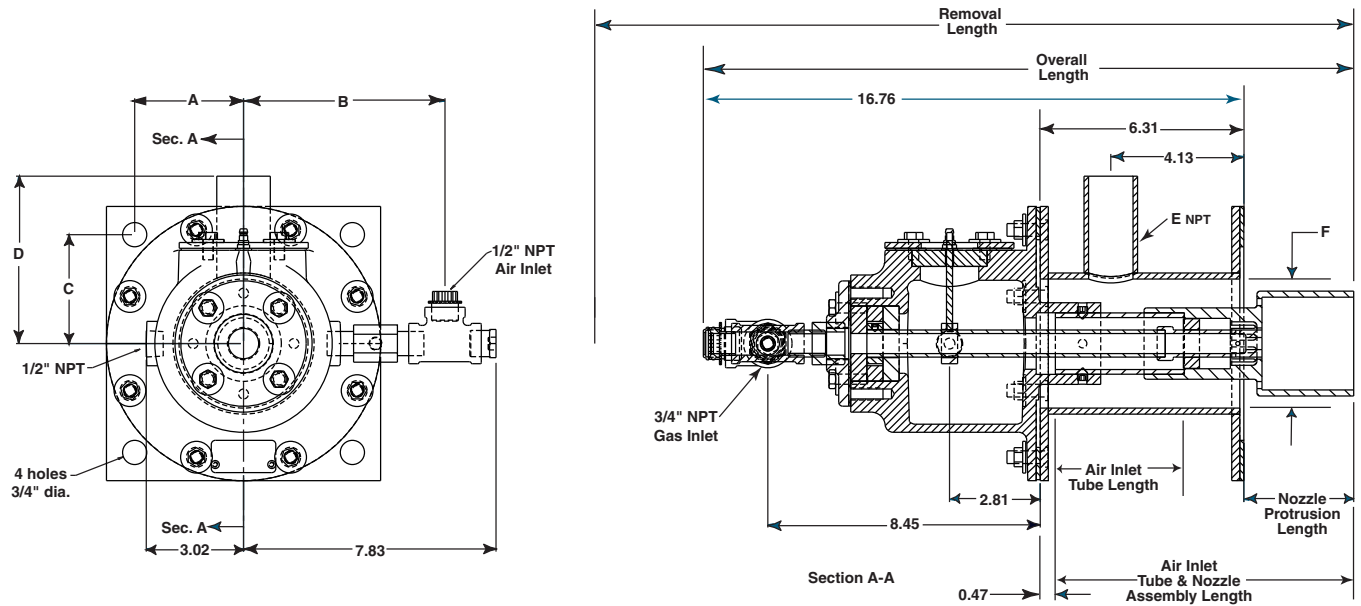

Housing Size*	A	B	C	D	E NPT	F I.D.
0125 0400 UR	3.38	6.25	3.38	5.19	1-1/4"	4.0
0125 0500 UR	3.38	6.25	3.38	5.19	1-1/4"	5.0
0150 0400 UR	3.38	6.23	3.38	5.19	1-1/2"	4.0
0150 0500 UR	3.38	6.23	3.38	5.19	1-1/2"	5.0
0150 0600 UR	3.38	6.23	3.38	5.19	1-1/2"	6.0
0150 0700 UR	3.38	6.23	3.38	5.19	1-1/2"	7.0
0200 0600 UR	3.63	6.25	3.63	7.19	2"	6.0
0200 0700 UR	3.63	6.25	3.63	7.19	2"	7.0
0200 0800 UR	3.63	6.25	3.63	7.19	2"	8.0

\*Refers to size of burner housing; dimension "E" (NPT) and dimension "F" (inside diameter)

Air Inlet Tube Length	Removal Length	Overall Length	Nozzle Protrusion Length	Air Tube & Nozzle Assembly Length	Gas Tube Assembly
4.0"	29.0"	20.2"	3.4"	9.25"	11.75"
7.0"	32.0"	23.2"	6.4"	12.25"	14.75"
9.5"	34.5"	25.7"	8.9"	14.75"	17.25"
11.5"	36.5"	27.7"	10.9"	16.75"	19.25"
13.5"	38.5"	29.7"	12.9"	18.75"	21.25"
15.5" [1]	40.5"	31.7"	14.9"	20.75"	23.25"
17.5" [1]	42.5"	33.7"	16.9"	22.75"	25.25"

[1] Available by special request.

Dimensions (in inches)

UNI-RAD Burners - used with silicon carbide tubes

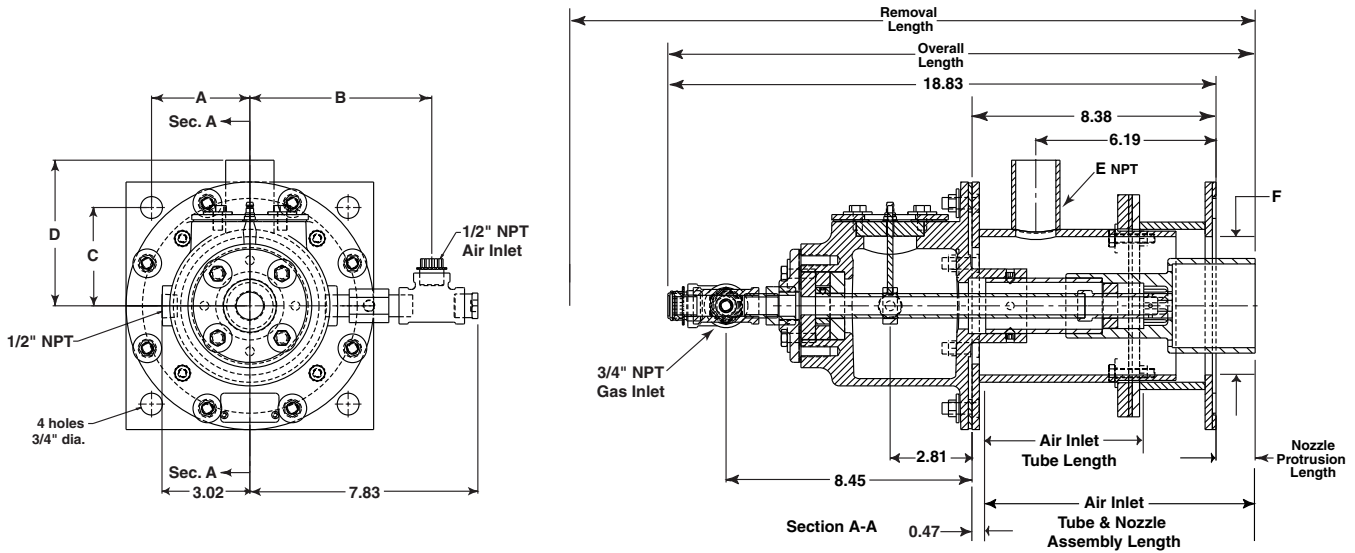

Housing* Size	A	B	C	D	E NPT	F I.D.
0125 0450C UR	3.38	6.25	3.38	5.19	1-1/4"	4.5
0150 0600C UR	3.38	6.25	3.27	5.19	1-1/2"	6.0

\*Refers to size of burner housing; dimension "E" (NPT) and dimension "F" (inside diameter)

Air Inlet Tube Length	Removal Length	Overall Length	Nozzle Protrusion Length	Air Tube & Nozzle Assembly Length	Gas Tube Assembly
4.0"	31.0"	20.2"	1.3"	9.25"	11.75"
7.0"	34.0"	23.2"	4.3"	12.25"	14.75"
9.5"	36.5"	25.7"	6.8"	14.75"	17.25"
11.5"	38.5"	27.7"	8.8"	16.75"	19.25"
13.5"	40.5"	29.7"	10.8"	18.75"	21.25"
15.5" [1]	42.5"	31.7"	12.8"	20.75"	23.25"
17.5" [1]	44.5"	33.7"	14.8"	22.75"	25.25"

[1] Available by special request.

# Dimensions (in inches)

## MAX-SAVER Recuperator - 1.25"

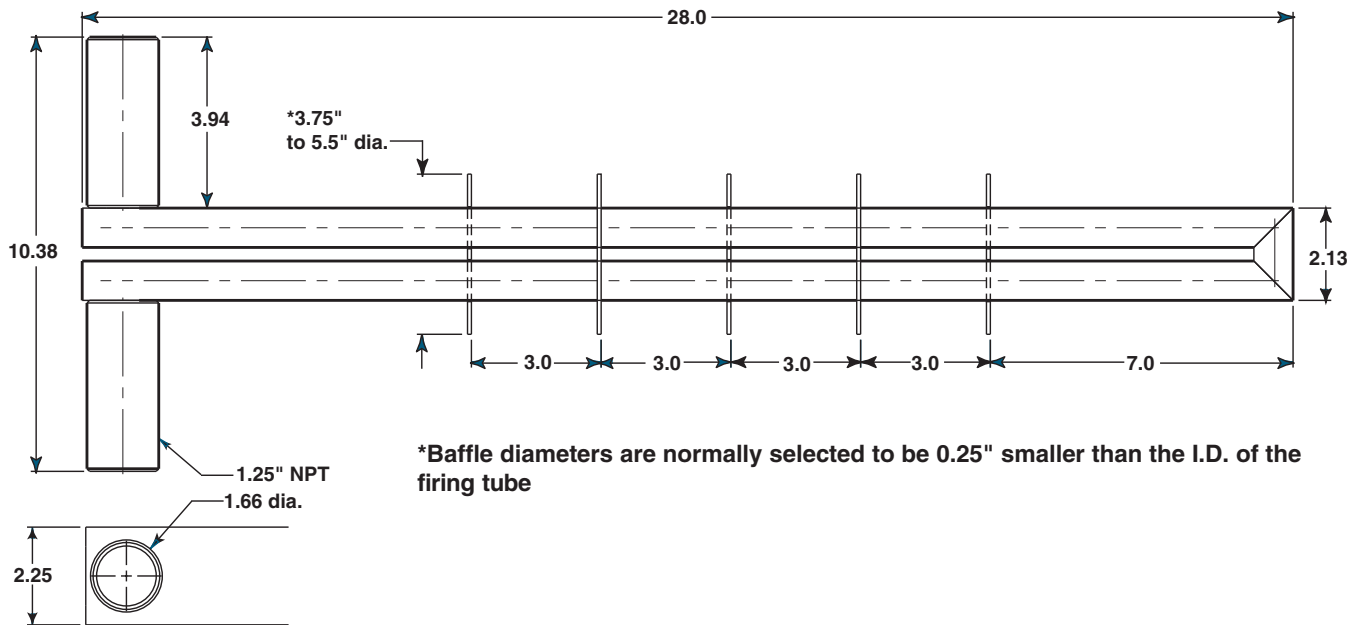

MaxSaver® 1.25" Recuperator  
Pressure Drop vs. Flow at Various Preheat Temperatures

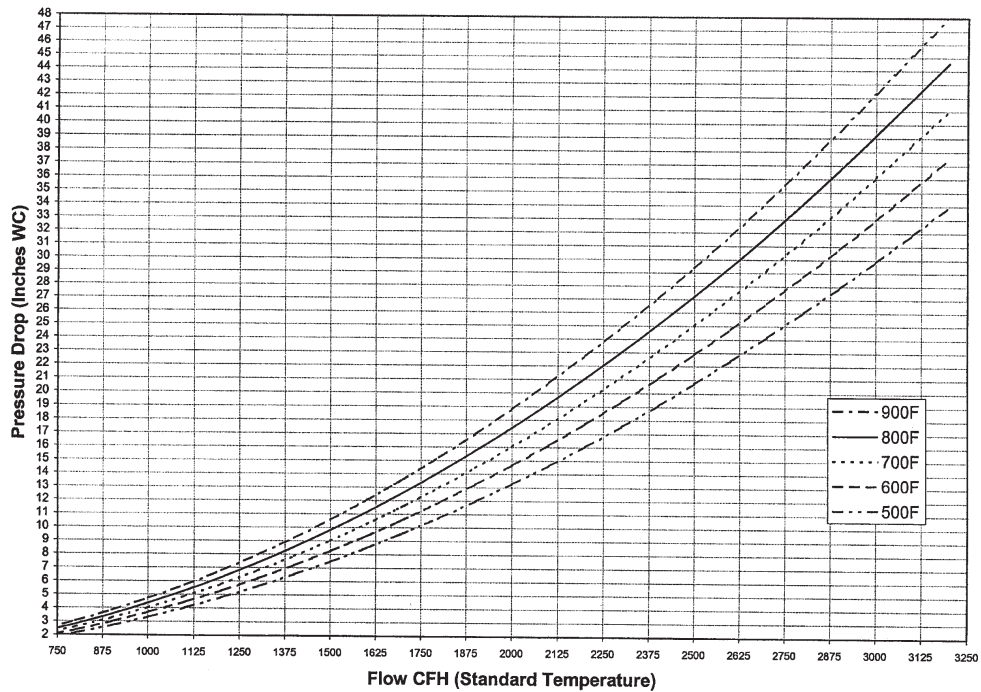

# Dimensions (in inches)

## MAX-SAVER Recuperator - 1.5"

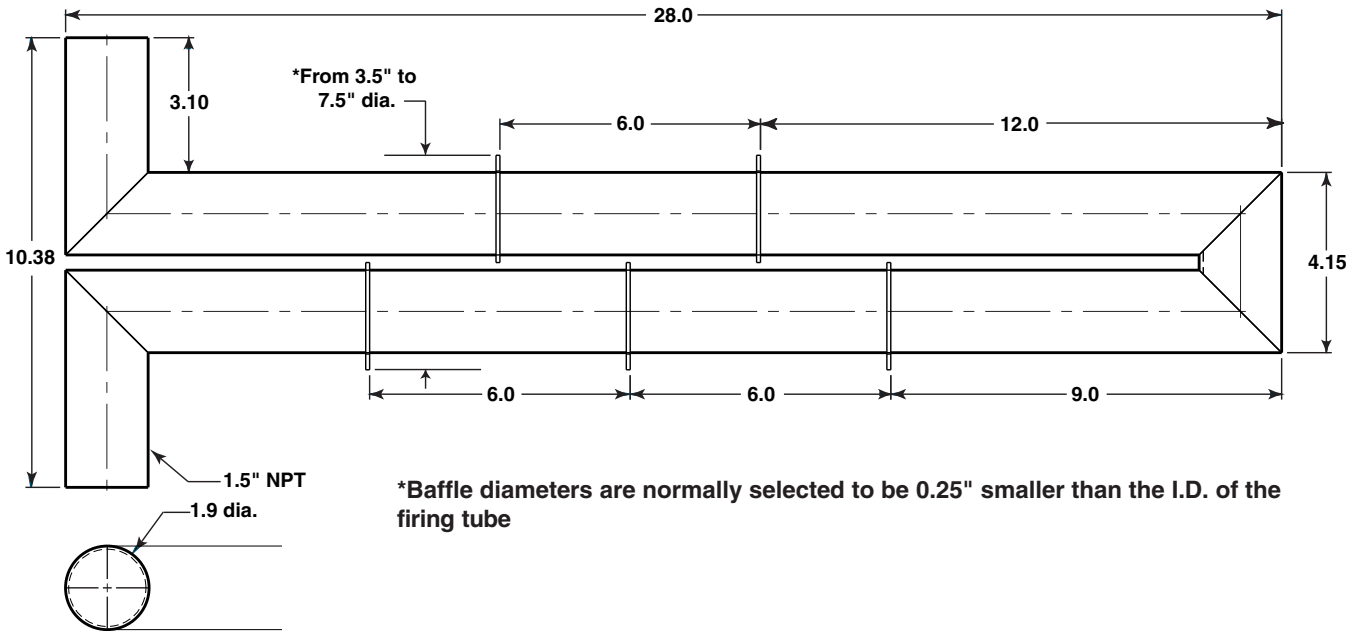

MaxSaver® 1.5" Recuperator  
Pressure Drop vs. Flow at Various Preheat Temperatures

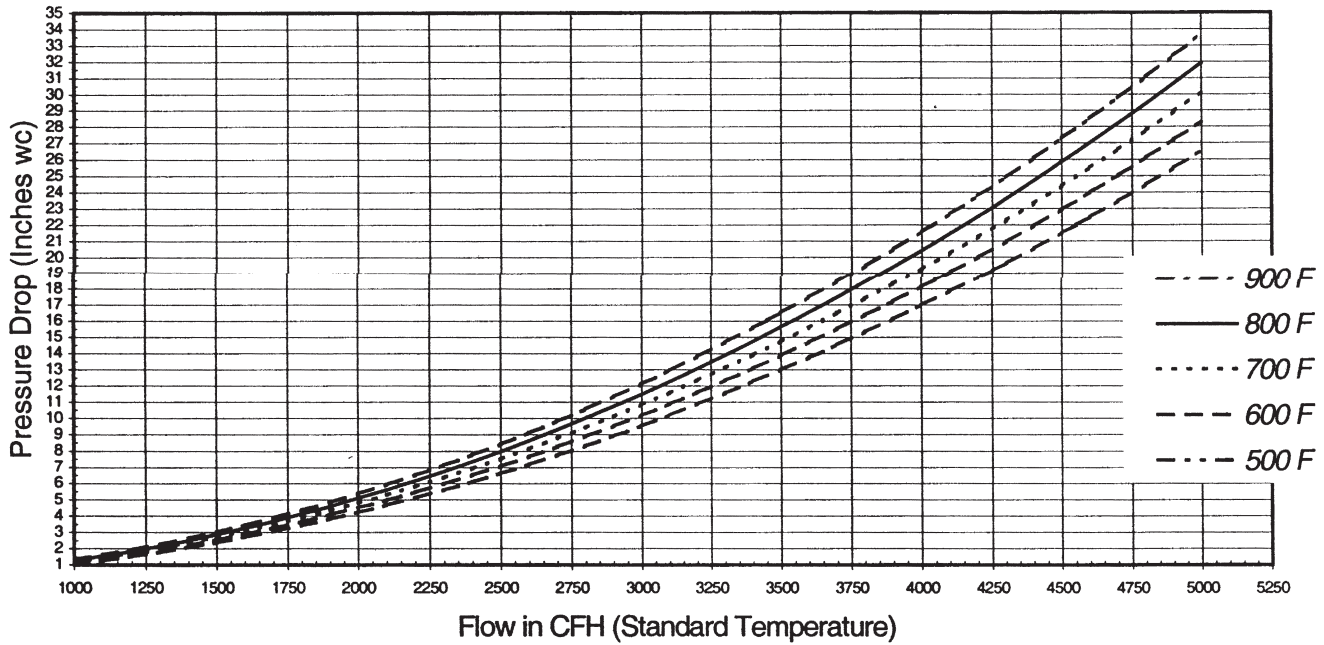



# Dimensions (in inches)

## MAX-SAVER Recuperator - 2"

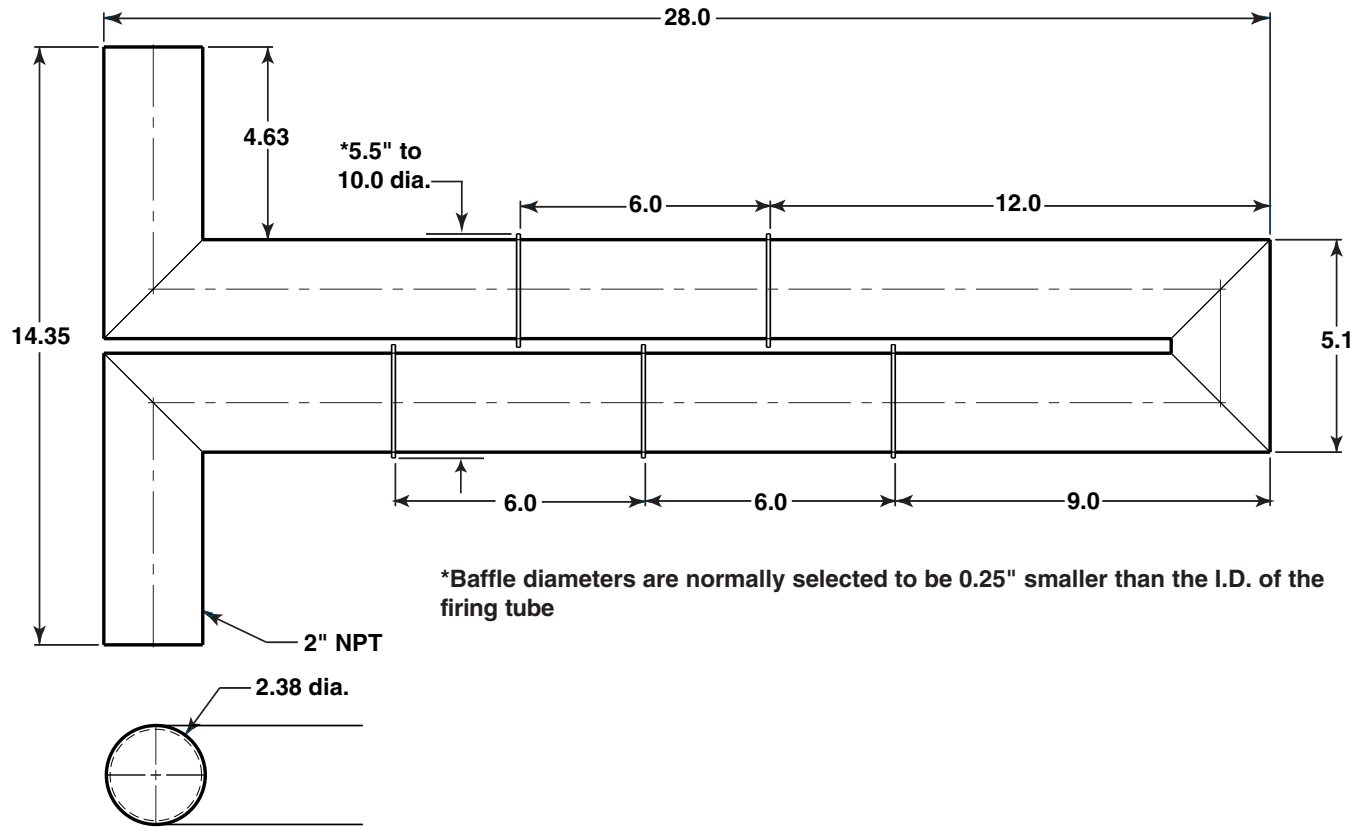

MaxSaver® 2" Recuperator  
Pressure Drop vs. Flow at Various Preheat Temperatures

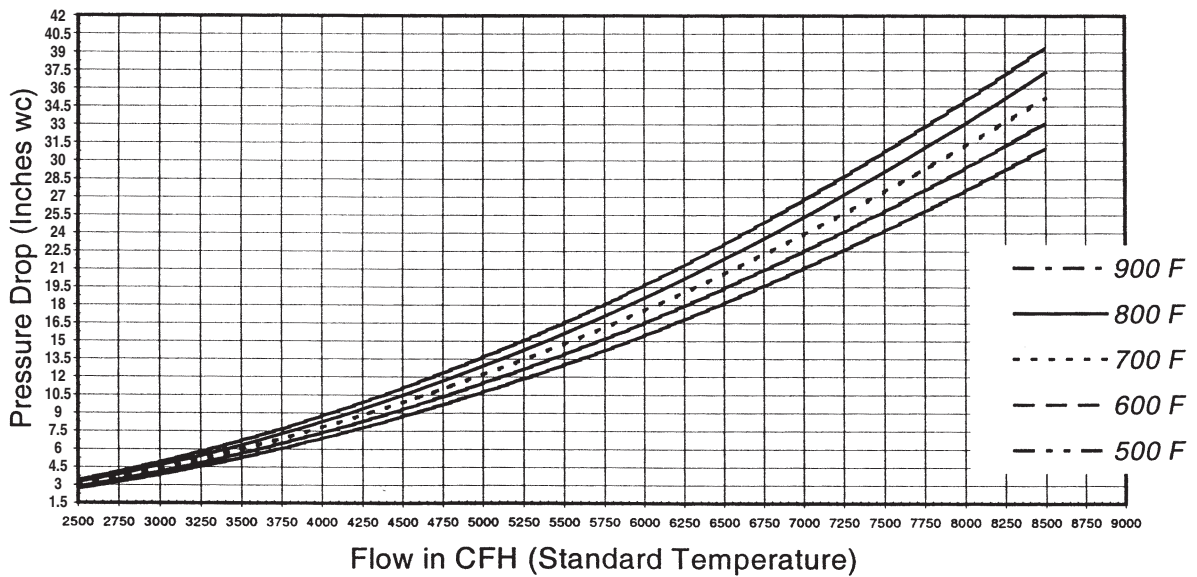

# UNI-RAD Burner Component Identification

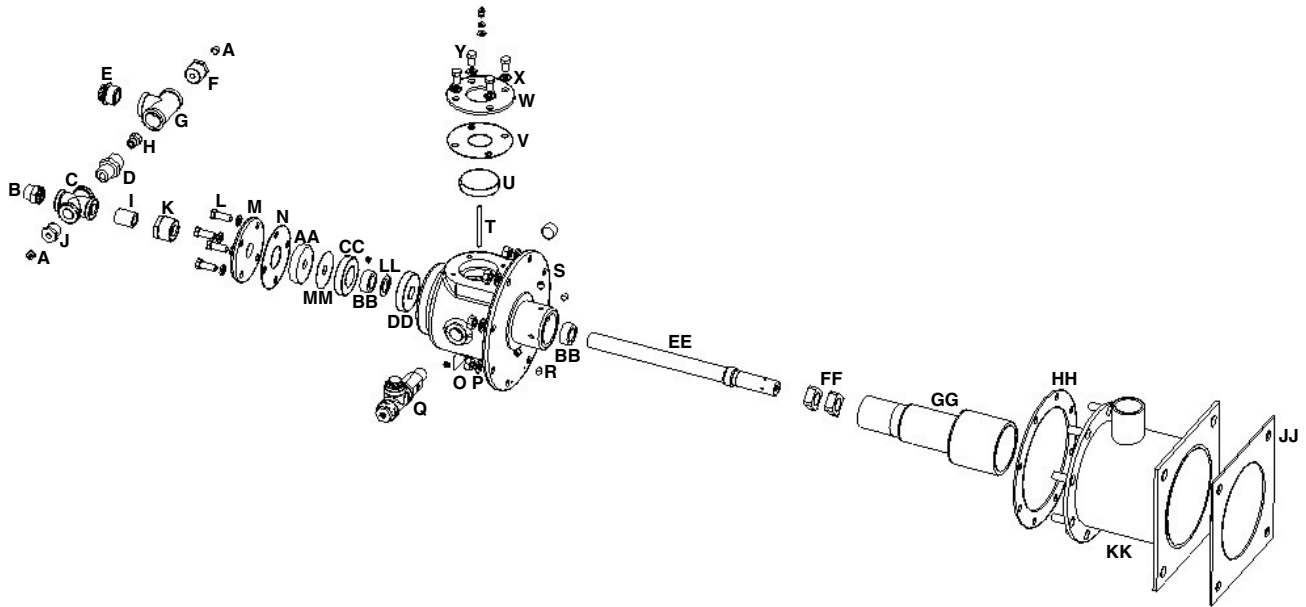

Item	Part Number	Description
A	20410	.125" HLW PIPE PLUG
B	19284	.5" NPT OBSVTN GL
C	57943	.5" MALL CR
D	57942	.5" -27 SPUD HLDR
E	20160	.75" CA-PLUG
F	57939	.75" X .125" STL HEX BSHG
G	26284	.75" X .75" X .75" MALL TEE
H	57940	.5" - 27 BR SPUD - MAIN GAS
I	20443	.5" BLK STL CLS NPL
J	21012	.5" X .125" STL HEX BSHG
K	37072	1" X .5" STL HEX BSHG
L	54510	M8 X 25 ISO4017 PLTD HEX
M	17318	1" FLG
N	1050577	UNI-RAD BRNR GSKT
O	54512	M8-1.25 PLTD FIN HEX NU
P	1039932	M8-PLN ISO 7089 WSHR CLS
Q	1053385	UNI-RAD IGN AIR PIPE ASY
R	1053397	M9X10 CONE PT SET SCR
S	1053214	BRNR HSG

Item	Part Number	Description
T	57956	IGN ROD
U	57968	.25" IDE INSL
V	1050577	UNI-RAD BRNR GSKT
W	57970	IGN INSL RETN FLG
X	1039932	M8-PLN ISO 7089 WSHR CLS
Y	1046010	M8X16 ISO4017 SS HEX HD
Z	53529	IGN TERM CAP
AA	1050671	.625" ID CRMC INSL
BB	57947	GAS INLT HLDG CLR
CC	57955	1.375" ID INSL
DD	57948	.875" ID INSL
EE	---	GAS INLT TB ASY
FF	57971	CRMC CNTRG SPDR
GG	---	AIR TUBE & NOZZLE ASY
HH	58030	BRNR CSTG GSKT
JJ	---	AIR INLT GSKT
KK	---	BRNR AIR INLT HSG
LL	1114783	UNI-RAD SM BRNR GSKT
MM	1114784	UNI-RAD LG BRNR GSKT

For part numbers of shaded items, see next page

## UNI-RAD Burner Component Identification

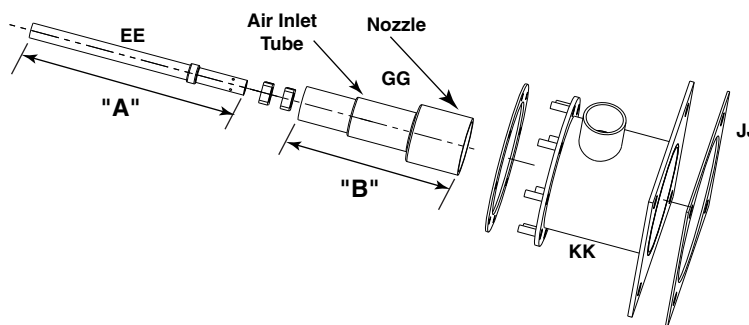

### Item "EE" - Gas Inlet Tube Assembly

Air Inlet Tube Length	Dimension "A" Gas Inlet Tube Assembly Length	EE GAS INLT TB ASY
4.0"	11.75	58058
7.0"	14.75	57959
9.5"	17.25	58050
11.5"	19.25	58054
13.5"	21.25	1041716
15.5" [1]	23.25	1053155
17.5" [1]	25.25	1053156

### Item "GG" - Air Tube & Nozzle Assembly

Air Inlet Tube Length	Dimension "B" Air Tube & Nozzle Assembly Length	GG AIR TUBE & NOZZLE ASY
4.0"	9.25	58056
7.0"	12.25	57958
9.5"	14.75	58048
11.5"	16.75	58052
13.5"	18.75	1053137
15.5" [1]	20.75	1053138
17.5" [1]	22.75	1053139

NOTE: Air tube and nozzle available only as an assembly, not separate items

### Item "JJ" - Air Inlet Gasket

Housing Size	JJ AIR INLT GSKT
0125 0400 UR	57975
0125 0450C UR	57976
0125 0500 UR	57976
0150 0400 UR	57975
0150 0500 UR	57976
0150 0600 UR	58286
0150 0600C UR	58286
0150 0700 UR	58283
0200 0600 UR	1053360
0200 0700 UR	1053360
0200 0800 UR	1053360

### Item "KK" - Burner Air Inlet Housing for alloy tubes (pictured above)

Housing Size	KK BRNR AIR INLT HSG
0125 0400 UR	1053164
0125 0500 UR	1053065
0150 0400 UR	1053166
0150 0500 UR	1053167
0150 0600 UR	1053068
0150 0700 UR	1053169
0200 0600 UR	1053170
0200 0700 UR	1053171
0200 0800 UR	1053172

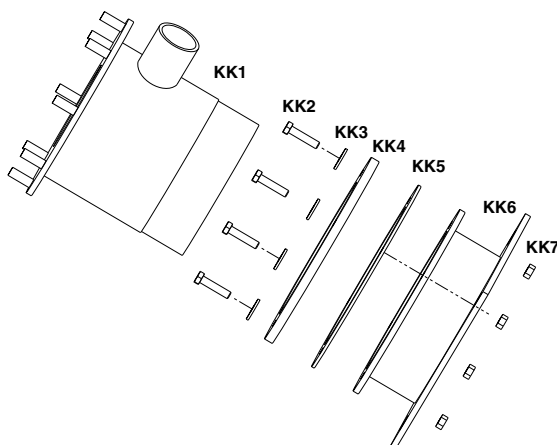

### Item "KK" - Burner Air Inlet Housing for silicon carbide tubes (pictured at left)

Tube Size	KK1 Housing	KK2 Screw	KK3 Washer	KK4 Ring	KK5 Gasket	KK6 Plg Gland	KK7 Nut
4.5"C	1053173	54630	1039932	1053232	1053250	1053233	54625
6"C	1053174	54630	1039932	1053236	1053251	1053235	54625

[1] Available by special request.

## Notes