

Specifications of MAXON VALUPAK® burners for 50 Hz operation

Capacity data in Btu									
Gross heating value = 1000's Btu/ft ³ (st), d = 0.6. All figures are for balanced - 0 "wc - duct pressure									
VALUPAK® size		60 [1]			150 [1]	300 [1]	600	800	1000
Standard blower type		UHC102	UHC122	UMI300					
Maximum heat release [2]	MBtu/h (HHV)	0.14	0.20	0.27	0.63	1.11	2.20	3	3.84
Minimum heat release	MBtu/h (HHV)	0.007	0.007	0.01	0.014	0.03	0.06	0.06	0.06
Turndown		20:1	30:1	27:1	46:1	36:1	36:1	49:1	62:1
Gas Q max.	ft ³ /m	2.18	3.24	4.30	10	17.66	34.73	47.67	60.62
Gas Q min.	ft ³ /m	0.11	0.11	0.16	0.22	0.47	0.97	0.97	0.97
Max. combustion air volume	ft ³ /m	28.25	37.67	57.68	106	183	459	688	688
Gas pressure at test connection at maximum heat release	"wc	2.17	3.61	7.23	1	0.40	0.88	0.68	1.32
Air diff. pressure at test connection at maximum heat release	"wc	0.80	1.32	2.93	1.08	1.37	3.01	1.73	1.73
Air diff. pressure at test connection at minimum heat release	"wc	0.12	0.08	0.12	0.12	0.16	0.24	0.04	0.04
Air diff. pressure at pressure switch									
at maximum heat release	"wc		n/a		0.92	1.24	1.69	1.37	2.97
at minimum heat release	"wc		n/a		1.08	1.73	2.13	2.61	3.21
Blower motor 3x220-420x50 Hz	Hp		0.12		0.12	0.25	1.5	1.5	1.5
Weight	lbs		n/a		27.56	36.38	88.18	103.62	110.23

[1] Single phase blower motor available.

[2] Use of the standard round air inlet filter will cause a ±15% capacity reduction.

Use of the standard VALUPAK® burner at 60 Hz will result in a higher max. capacity to which the gas pressures need to be adapted.

Distributed by:



888.858.3647 | relevantsolutions.com

Installation and operating instructions

Installation instructions

Instructions provided by the company or individual responsible for the manufacture and/or overall installation of a complete system incorporating MAXON burners take precedence over the installation and operating instructions provided by MAXON. If any of the instructions provided by MAXON are in conflict with local codes or regulations, please contact MAXON before initial start-up of equipment.



Read the combustion system manual carefully before initiating the start-up and adjustment procedure. Verify that all of the equipment associated with and necessary to the safe operation of the burner system has been installed correctly, that all pre-commissioning checks have been carried out successfully and that all safety related aspects of the installation are properly addressed.



Do not discard packing material until loose items are accounted for.
To prevent damage in transit spark ignitor and linkage (if any) are shipped “loose”.

Burner mounting

See sketch page 1-1.5-9. Burner may be mounted in any position suitable for automatic control motor and UV scanner. Burner will typically be installed through an oven wall or insulated air duct. Cut opening at least 0.98 inch larger in diameter than discharge sleeve to allow for sleeve expansion. Additional burner support may be required in conjunction with a stiffener plate to support burner package weight (44-55 lbs). Four 0.51 inch diameter holes into panels flange accept 0.39 inch stud bolts welded to panels or stiffener.



IMPORTANT: seal welding of burner flange to stiffener plate at (A) may cause warpage of burner flange and require additional seal material to prevent leakage.

For push-through systems, area (A, see drawing page 1-1.5-9) should be sealed with additional gasketing or high temperature packing, to prevent back flow of high temperature air. Fill area (B, see drawing page 1-1.5-9) with **no more than 1.97 inch** of high temperature packing (too little will overheat mounting, too much will overheat sleeve).

For pull-through systems, spacers may be installed on stud bolts and area (B, see drawing page 1-1.5-9) left empty to permit cooling air past the sleeve. Four lock screws permit centering mixing cone within burner body and sleeve. They should be drawn up hand-tight, then backed out 180° to allow for cone expansion. They must be rechecked after start-up and loosened if necessary to prevent deformation of cone. See start-up instruction for details.

Tightening can lead to cone distortion and greatly reduced cone and discharge sleeve life.

Discharge sleeve must be flush with, or extended beyond interior wall.

A viewing port should be provided for flame observation in such a position that burner flame can be fully seen.



Installer must comply with all applicable codes and standards.
Observe required space for parts removal.

Installation of flame scanner

Instead of a flame rod, a flame scanner can be applied to a VALUPAK® burner (with exception of VALUPAK® 60) for the purpose of flame detection with little modification. A 3/8" plug has to be installed in the nozzle center for the VALUPAK® 150, 300 and 600. For VALUPAK® 800 and 1000 no modification is required.

- 1) Stiffener plate
- 2) Lock screw
- 3) Discharge sleeve
- 4) Viewing port
- 5) Additional burner support
- 6) Stud bolt
- 7) Air pressure switch (option)
- 8) Air filter (option)
- 9) Air supply
- 10) Fuel supply
- 11) Space required for spark ignitor removal
- 12) Oven wall
- 13) Control motor (option)
- 14) Air supply
- 15) Fuel supply
- 16) Space required for flame rod/scanner removal

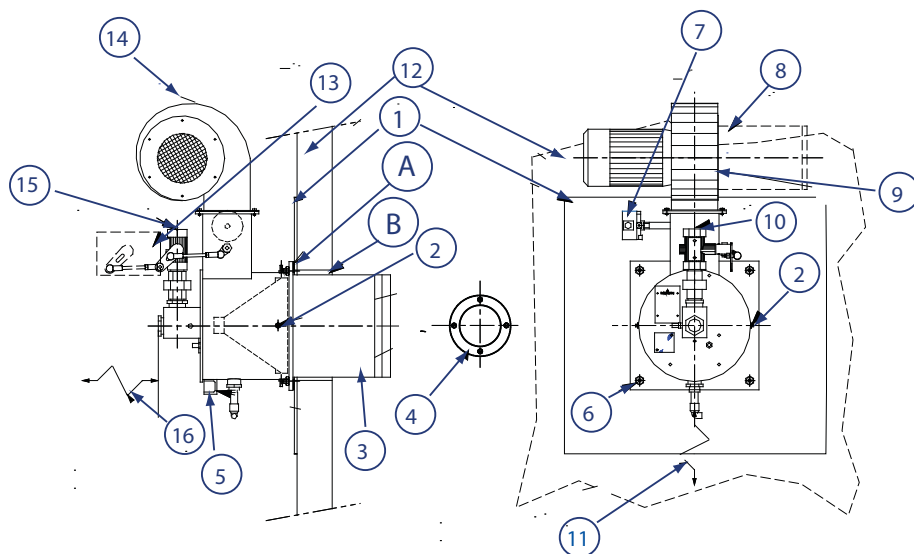

Flame rod or UV scanner arrangement with spark ignitor

Sizes VP 60 - VP600

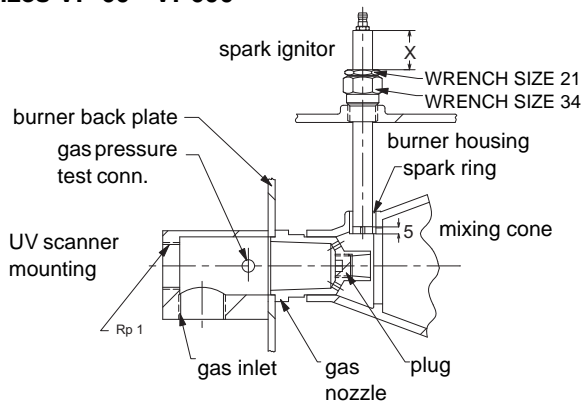

Sizes VP800 and VP1000

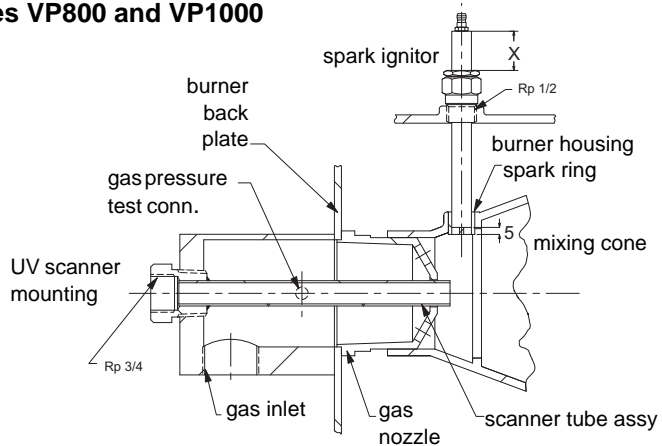

Sizes VP60 - VP600

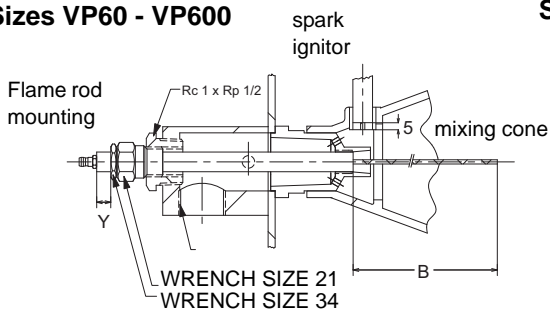

Sizes VP800 and VP1000

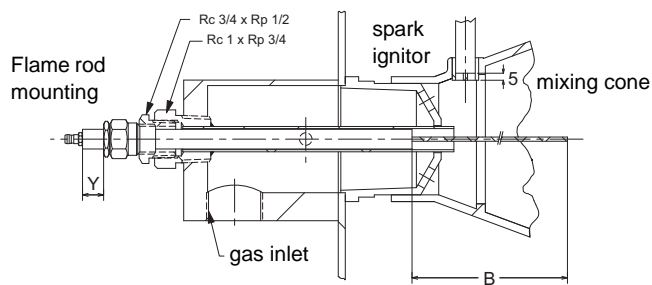

Dimensions in inches, unless stated otherwise

MODEL VALUPAK®	SPARK IGNITOR	FLAME ROD	
	X	Y	B
VP 60		page 1-1.5-11	
VP 150	2.6	0.6	6.0
VP 300	1.6		
VP 600	1.4		
VP 800	1.0	0.6	12.6
VP 1000			

Spark ignitor arrangement for VALUPAK® 60

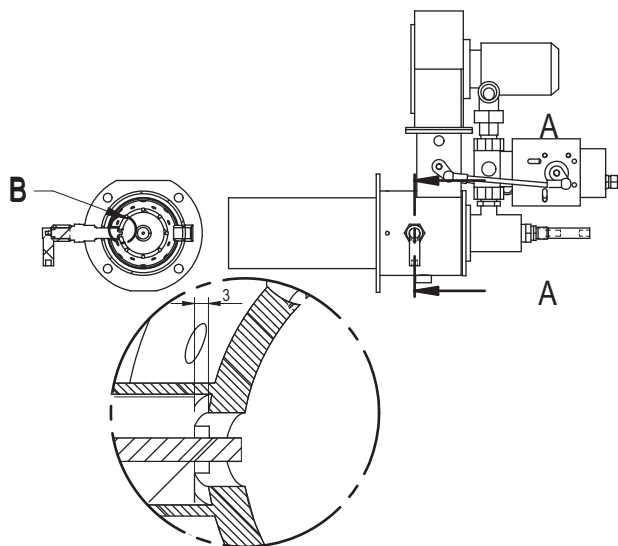

The spark ignitor can be mounted in 3 different positions on the burner housing : left, right and bottom (if the air inlet is on top).
Spark ignitor replacement : insert the spark ignitor through the collar into the burner. Insert the spark ignitor in the cone bushing until its ceramic touches the cone - then retract the spark ignitor 0.12 inch to establish proper gap.

Flame rod arrangement for VALUPAK® 60

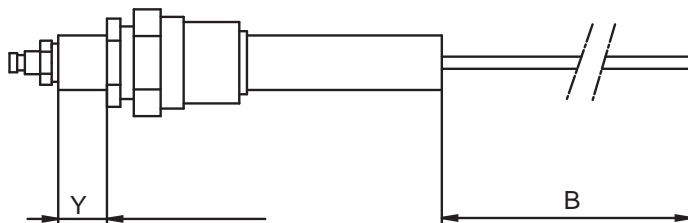

Dimensions in inch, unless stated otherwise			
MODEL VALUPAK®	VP 60		
Blower type	UHC102	UHC122	UMI300
Maximum PCS in MBtu (HHV)	0.14	0.20	0.27
Dimension B	2.56	5.98	5.98
Adjustment dimension Y	2.76	2.76	2.76

The flame rod is located at the back of the burner, through the gas inlet block and gas nozzle. It is important that the flame rod is mounted gastight ! The recommended adjusting dimension shall be respected.

Operating instructions

The operating instructions below are provided only as a guideline and are not intended to replace those provided by the manufacturer of a complete system of which the VALUPAK® burner is only a part. Where applicable, instructions provided by the system's manufacturer shall take precedence.

Start

1. Make sure trip release shut-off valve and main gas cock are all closed.
2. Make sure the burner firing rate control handle is at predetermined low fire "LO" position.
3. Start all circulating and exhaust fans.
4. Energize system control panel (if applicable).
5. Start burner blower motor.
6. Open main gas cock.
7. Press start button.
8. Main gas valve will open (only if all safety circuits are complete).

Stop

1. Push STOP button and
2. Main gas valve should automatically close.
3. De-energize system control panel and burner blower motor.
4. Close main gas cock.

Start-up and adjustment instructions for VALUPAK® burners

Instructions provided by the company or individual responsible for the manufacture and/or overall installation of a complete system incorporating MAXON burners take precedence over the installation and operating instructions provided by MAXON. If any of the instructions provided by MAXON are in conflict with local codes or regulations, please contact MAXON before initial start-up of equipment.



Before initiating the following start-up and adjustment procedure, it is important that a check be made to verify that all of the equipment associated with and necessary to the safe operating of the VALUPAK® burner system has been installed and piped in accordance with the “General installation instructions”. If the burner system is part of an oven or other heating unit which has been purchased as a complete pre-piped and pre-wired package, it may be assumed that these instructions have already been carried out by the individual or company responsible for the overall installation.

Initial adjustment and light-off should be undertaken only by trained and experienced personnel familiar with combustion systems, with control/safety circuitry and with knowledge of the overall installation.

To start-up a VALUPAK® burner for the first time

5. **Close main gas cock.**
Check tightness of gas piping. Connect U-tube manometer to burner test connection on the burner gas nozzle inlet. Note burner type and required gas pressure (page 1-1.5-14).
6. **Establish correct blower direction of rotation of all fans.** See arrow on blower housings.
7. **Disconnect automatic control motor wiring to avoid unexpected motor travel.**
Check that gas control valve is at low fire position (as supplied). For size 150 and 300 control motor rotation is counter clockwise when looking towards controls linkage going from low to high fire. For size 600, 800 and 1000 control motor runs clockwise from low to high.
8. **Bleed air from the fuel supply line.**
Remove the cover from the gas pressure regulator and establish that regulator is at low end of control range.
9. **Check the adjustments of the flame rod and spark ignitor.** (See page 1-1.5-10 and the wiring).
10. **Start all machine air blowers.** Start burner with its start-stop switch. Motor of combustion air fan will be started shortly after, by means of the burner flame safeguard programming relay.
11. **Purge the combustion chamber,** purging any explosive vapors that may have accumulated prior to the start. The length of purge time required will usually be specified by insurance or approval agency having jurisdiction and depends on the total amount of fresh air and the volume of combustion space. A 5-fold refresh rate should be minimum. At the end of the purge time of the burner flame safeguard programming relay ignition is energized and the main gas valve will be energized shortly after.
12. **Because main gas cock** is closed the programmer will lock out requiring manual reset. Operation of programmer is correct.
13. **Check setting** of low and high gas pressure switches and combustion air pressure switch.
14. **Check burner control valve** at LO position.
15. **Slowly open main gas cock.** Reset burner relay and start burner.

16. After the burner flame safeguard programmer relay prepurge time ignition is energized and main gas valve opened. Flame should be established within safety time of programmer. If again flame failure, air could still be in gas supply line just before burner. Reset programmer and restart until low fire flame is established. Check gas supply pressure with information on page 1-1.5-14 and correct with adjusting screw of gas pressure regulator. Observe flame through observation port at rear of burner.
17. **Slowly bring burner to high fire position** and avoid maximum temperature of dryer. Check and correct gas pressure on burner test connection and adjust to value given on page 1-1.5-14. Close cover on pressure regulator and adjust all pressure switches.
High gas pressure switch at low fire.
Low gas pressure switch at high fire.
Air pressure switch at high fire by closing of air inlet until flame color start to change. Burner should trip by air pressure switch.
18. **Reconnect control motor wiring**, start burner and change several times between low and high fire position by changing temperature controller settings.
19. **Check all other safety devices** such as pressure switches, high temperature limits etc. and adjust these devices to their correct values.