

WIDE-RANGE®

High Temperature Burners

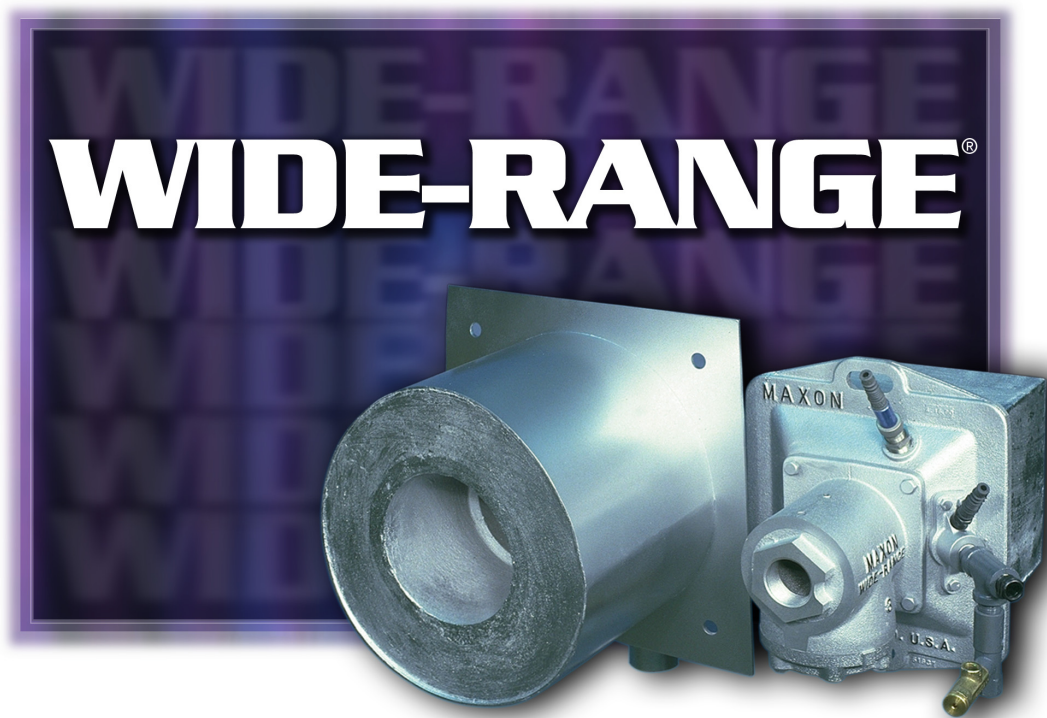

- Burns most low-pressure gaseous fuels, including low-Btu waste gases and hydrogen
- Flame retention at all firing rates with multi-stage stepped-tunnel refractory block design
- Faster bring-up times without temperature override with 40:1 turndown capability
- Maximum application flexibility provided with eight sizes and capacities up to 13,500,000 Btu/h
- On-ratio firing over a broad range of operating conditions
- Alternate refractory block materials for temperatures up to 3000°F gives maximum cost effectiveness

Distributed by:



888.858.3647 | relevantsolutions.com

W W W . M A X O N C O R P . C O M

COMBUSTION SYSTEMS FOR INDUSTRY

Maxon reserves the right to alter specifications and data without prior notice.
© 2012 Copyright Maxon Corporation. All rights reserved.

A Honeywell Company

Product description

WIDE-RANGE® Burners provide exceptional reliability and flexibility with an innovative nozzle mixing design.

Combustion air enters the burner body, surrounds the gas insert nozzle, and exits through the air ports on the face of the gas insert nozzle.

Low pressure gas enters the gas insert nozzle and is directed out the gas ports, where it is intimately mixed with the combustion air in the multi-stage burner block tunnel.

A pilot port tunnel and a flame supervision port intersect the main burner tunnel directly in front of the nozzle face. At this three-way tunnel intersection, the flame safeguard (the flame detector) monitors the pilot flame and/or main burner fire.

- 1) Stepped burner block
- 2) WIDE-RANGE® Burner center line
- 3) Pilot tunnel center line
- 4) Mounting frame
- 5) Burner body
- 6) Combustion air inlet
- 7) Gas inlet
- 8) Gas insert nozzle
- 9) Air ports
- 10) Flame supervision port center line

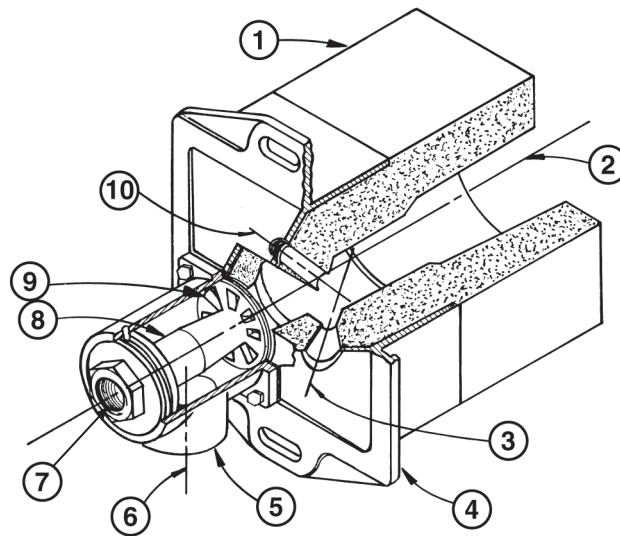

Available WIDE-RANGE® burner sizes

Typical burner data										
Fuel: natural gas at 60°F with 1000 Btu/ft ³ (st) HHV - sg = 0.6 [1]										
Combustion air: 60°F - 21% O ₂ - 50% humidity - sg = 1.0 [1]										
Stated pressures are indicative. Actual pressures are a function of air humidity, altitude, type of fuel and gas quality.										
WIDE-RANGE® Burner size			1-1/4"	1-1/2"	2"	2-1/2"	3"	4"	6"	8"
Maximum capacities (MBtu/h)	Inlet air pressures " wc	24	0.23	0.45	0.68	1.05	1.8	3.0	7.50	13.5
		17	0.19	0.38	0.57	0.93	1.6	2.65	6.60	11.5
		10	0.15	0.3	0.45	0.75	1.3	2.25	5.25	8.85
Minimum capacity (MBtu/h)			0.02	0.03	0.03	0.04	0.06	0.1	0.25	0.34

[1] sg (specific gravity) = relative density to air (density air = 0.0763 lb/ft³ (st))

Applications

WIDE-RANGE® Burners provide exceptional reliability with a large variety of gas fuels and waste gases. Its unique mixing pattern provides stable combustion and moderate emissions over a wide range of operation.

WIDE-RANGE® Burners are typically used on furnaces, kilns, lehrs and other processes with temperatures up to 3000°F. With the ability to operate at a variety of gas/air ratios, the WIDE-RANGE® is useful anywhere atmosphere control is desirable.

- 1) Burner
- 2) Flame detector
- 3) Combustion air blower
- 4) MAXON MICRO-RATIO® valve
- 5) Ignition transformer
- 6) Pilot burner
- 7) Sight glass

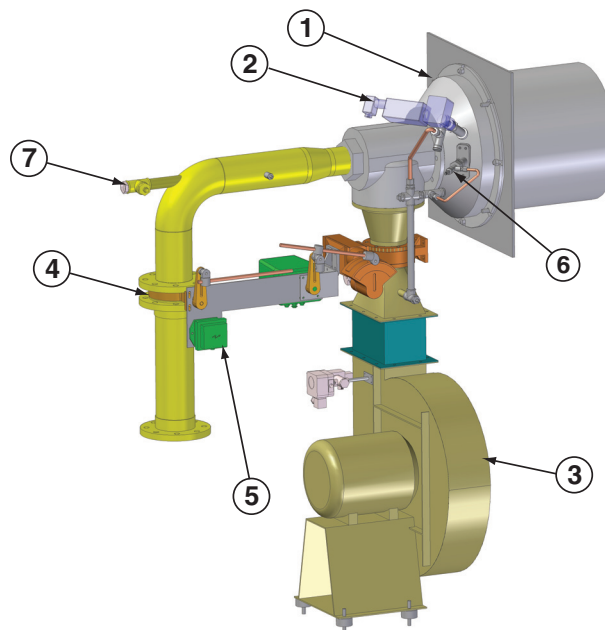

WIDE-RANGE® burner complete with combustion air blower and MAXON MICRO-RATIO® air/gas control system

Dimensions and weights

1-1/4" through 8" WIDE-RANGE® Burners

- 1) Standard block
- 2) Block with seal & support housing
- 3) Burner housing
- 4) Gas inlet
- 5) Pilot connection
- 6) Combustion air inlet
- 7) Flame sensor connection

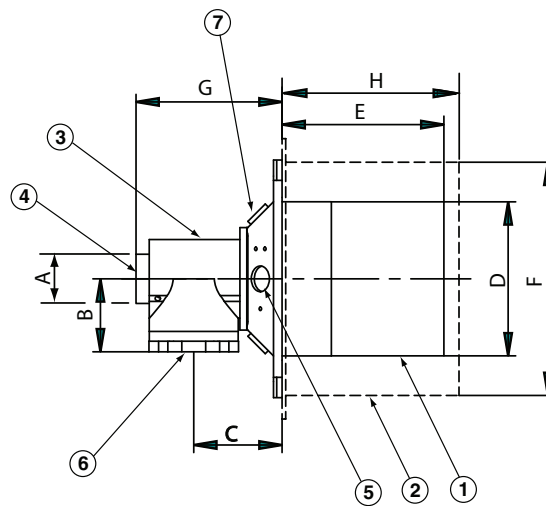

Dimensions in inches unless stated otherwise

Burner size (air inlet) [1] [2]	A [1] (gas inlet)	B	C	D sq.	E	F	G	H	Weight lbs [4]
1-1/4"	3/4"	2.0	3.0	5.0	7.5	8.06	5.1	7.5	79
1-1/2"	1"	2.0	4.5	7.5	9.0	11.62	6.8	9.0	99
2"	1"	2.38	4.5	7.5	9.0	11.62	7.0	9.0	121
2-1/2"	1-1/4"	3.0	4.0	9.0	9.5	13.56	6.9	9.5	205
3"	1-1/2"	4.12	4.75	9.0	9.44	13.56	8.1	9.44	209
4"	2"	5.0	5.56	11.5	11.5	17.5	9.7	11.5	309
6"	3"	7.19	10.69	16.38 [3]	10.50	17.5	16.6	16.0	425
8"	4"	9.62	10.56	18.0 [3]	8.12	24.5	18.56	18.7	780

[1] Connections are threaded (NPT or ISO). All connections sized 3" or above have optional welding flanges available. Refer to "Specifications of WIDE-RANGE® burners" for more details.

[2] Air inlet is a flanged connection for 8" WIDE-RANGE® burners. Threaded connection not available.

[3] Round

[4] Weight includes burner block

Typical emissions

WIDE-RANGE® Burners offer moderate levels of NO_x and CO production. With adequate fuel/air ratio control, such as is provided by SMARTLINK®, the burner can produce NO_x levels 20-40% less than conventional burners.

Exact emissions performance may vary in your application. Contact MAXON for information on installation-specific estimates and guaranteed values. No guarantee of emissions is intended or implied without specific, written guarantee from MAXON.

Read "Specifications of WIDE-RANGE® burners" for complete information on WIDE-RANGE® burners.