

NOTE: TERMINAL L1 MUST BE POWERED BEFORE TERMINAL 12

FORM 6642 VLT GROUP M

PROTECTOFIER MULTI-BURNER, MANUAL OPERATION, INCLUDES TIMER FOR PURGE AND IGNITION TRIAL.

SS100A FLAME PAK

ACF { C-CHECK RELAY
F-FLAME RELAY
L-LOAD RELAY

CTP - U300M MANUAL TIMOFIER



NO CONNECTIONS

NOTE:

TIMER CAMS (CTP) SHOWN IN ZERO TIME POSITION. CTP2 CLOSES BEFORE CTP1 OPENS.



** - JUMPER IN U300M MANUAL TIMOFIER: FOR IGNITION TRIAL UNITS ONLY.

Δ - FLAME FRLAY (F) CONTACTS 1 SET REQ'D. FOR EACH FLAME POSITION.

* - SAFETY INTLK. SERIES CIRCUIT. FUEL AND AIR PRESS. SWS., VENT. FANS, ETC. AS REQ'D.

WIRING DIAGRAM

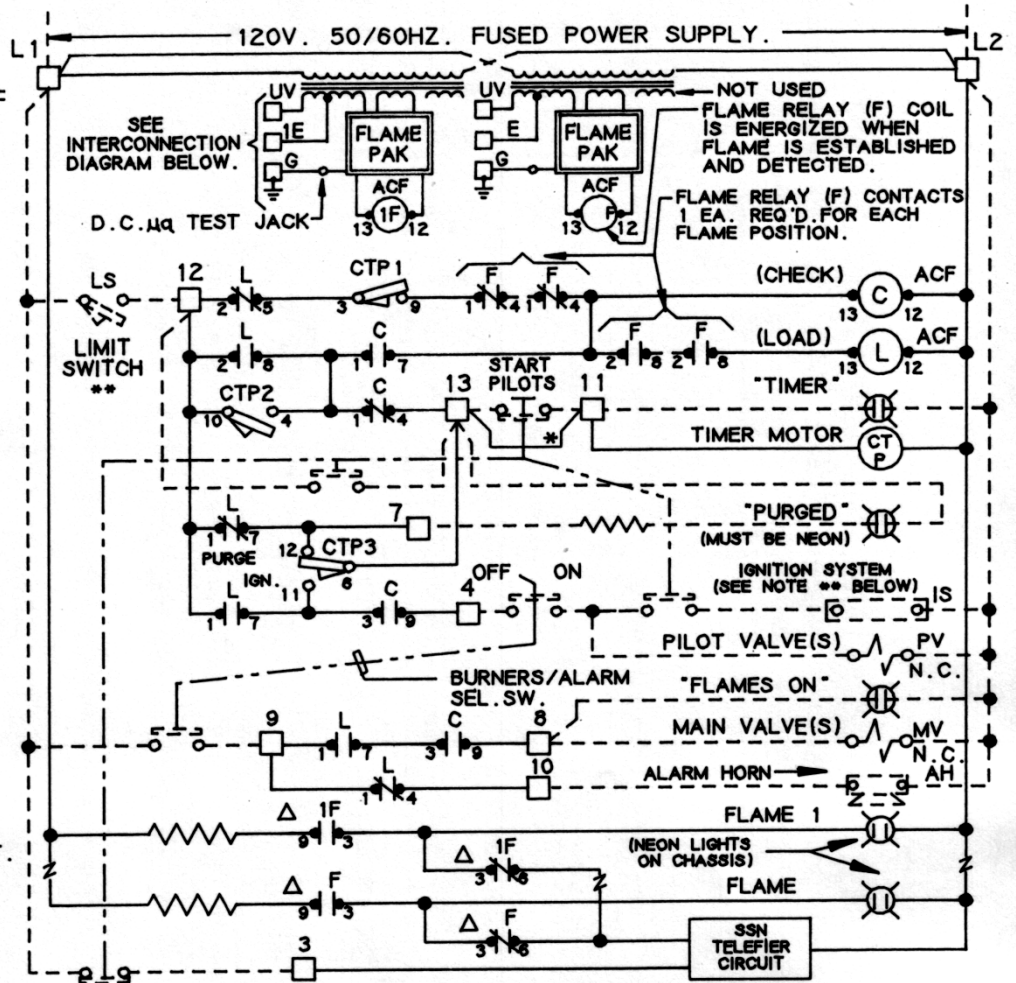

NOTE: TERMINAL L1 MUST BE POWERED BEFORE TERMINAL 12

120V. 50/60HZ. FUSED POWER SUPPLY.

NOTES:

FLAME WIRE TO BE NO. 14 TYPE TW. 600V. INSULATED WIRE OR EQUAL. FLAME WIRE MUST NOT BE IN SAME CONDUITS WITH POWER WIRING.

IGNITION CABLE MUST BE RUN IN SEPARATE CONDUIT TO SPARK ELECTRODE. (DO NOT MIX WITH 120V. WIRING.)

ALL WIRING AND EQUIPMENT EXTERNAL TO PROTECTOFIER TO BE FURNISHED BY OTHERS UNLESS OTHERWISE SPECIFIED.

INSTALLATION, OPERATION AND MAINTENANCE SHALL CONFORM WITH NATIONAL FIRE PROTECTION ASSOCIATION STANDARDS, NATIONAL AND LOCAL CODES AND AUTHORITIES HAVING JURISDICTION. ANY MODIFICATION VOIDS APPROVAL.

U300M MANUAL TIMOFIER TIMING		
RANGE	PURGE (MIN.)	IGN. (SEC.)
M	MIN.	SEC.

PROTECTION CONTROLS, INC. SKOKIE, ILLINOIS

WIRING DIAGRAM FOR: PROTECTOFIER FORM 6642VLT GROUP M

JOB NO.	REVISED	DRAWING NO.
	5-04	X-301

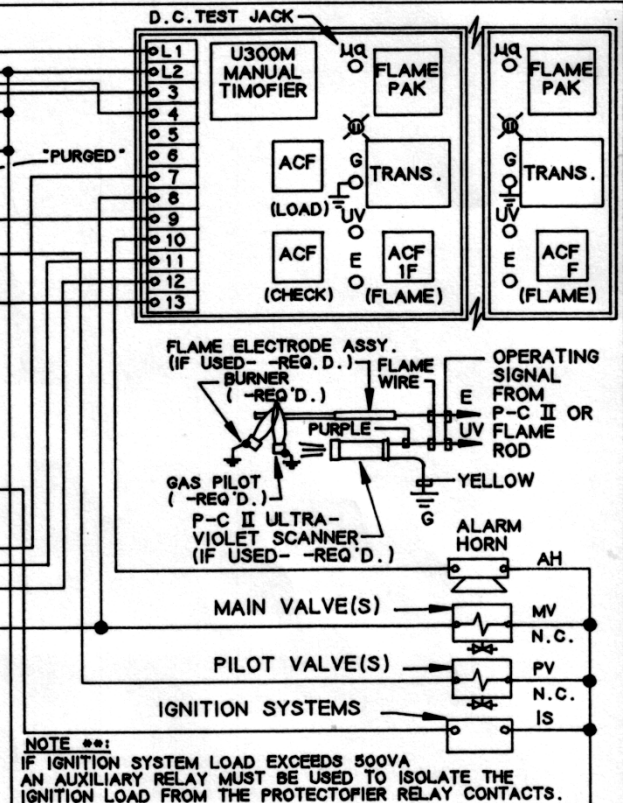

NOTE **: IF IGNITION SYSTEM LOAD EXCEEDS 500VA AN AUXILIARY RELAY MUST BE USED TO ISOLATE THE IGNITION LOAD FROM THE PROTECTOFIER RELAY CONTACTS.

INTERCONNECTION DIAGRAM