

SCADAPack E

5611 Input/Output Module Hardware Manual

Version: 8.14.3

Date: August 2017

Distributed by:



888.858.3647 | relevantsolutions.com



Table of Contents

1	Legal Information	5
2	Technical Support	6
3	Safety Information	7
4	Overview	10
5	Installation	11
6	Power Supply Overview and Requirements	13
	6.1 Recommended 24V Power Supply Configuration	13
7	DIP Switch Settings	15
8	Analog Inputs	16
	8.1 Current or Voltage Mode & Range and Resolution	16
	8.2 Wiring	16
9	Analog Outputs	21
	9.1 Current & Voltage Outputs	21
	9.2 Range and Resolution	21
10	Digital I/O Overview	24
	10.1 Digital Inputs & Outputs	24
	10.2 Wiring Examples	24
11	Operation and Maintenance	30
	11.1 Troubleshooting	30
	11.1.1 Analog Inputs & Outputs.....	30
	11.1.2 Digital Inputs & Outputs.....	30
12	Specifications	34
	12.1 General & Power Supply	34
	12.2 Analog Inputs	34
	12.3 Analog Outputs	34
	12.4 Digital Inputs	34
	12.5 Digital Outputs	34

13 Approvals and Certifications.....41

1 Legal Information

The information provided in this documentation contains general descriptions and/or technical characteristics of the performance of the products contained herein. This documentation is not intended as a substitute for and is not to be used for determining suitability or reliability of these products for specific user applications. It is the duty of any such user or integrator to perform the appropriate and complete risk analysis, evaluation and testing of the products with respect to the relevant specific application or use thereof. Neither Schneider Electric nor any of its affiliates or subsidiaries shall be responsible or liable for misuse of the information contained herein. If you have any suggestions for improvements or amendments or have found errors in this publication, please notify us.

No part of this document may be reproduced in any form or by any means, electronic or mechanical, including photocopying, without express written permission of Schneider Electric.

All pertinent state, regional, and local safety regulations must be observed when installing and using this product. For reasons of safety and to help ensure compliance with documented system data, only the manufacturer should perform repairs to components.

Trademarks

Schneider Electric, ClearSCADA, SCADAPack, Trio, Modbus, and StruxureWare are trademarks and the property of Schneider Electric SE, its subsidiaries and affiliated companies. All other trademarks are the property of their respective owners.

Address

Schneider Electric

415 Legget Drive, Suite 101, Kanata, Ontario K2K 3R1 Canada

Direct Worldwide: +1 (613) 591-1943

Fax: +1 (613) 591-1022

Toll Free within North America: 1 (888) 267-2232

www.schneider-electric.com

© 2014 - 2017 Schneider Electric Canada Inc.

All rights reserved.

2 Technical Support

Questions and requests related to any part of this documentation can be directed to one of the following support centers.

Technical Support: Americas, Europe, Middle East, Asia

Available Monday to Friday 8:00am – 6:30pm Eastern Time

Toll free within North America 1-888-226-6876

Direct Worldwide +1-613-591-1943

Email supportTRSS@schneider-electric.com

Technical Support: Australia

Inside Australia 1300 369 233

Email au.help@schneider-electric.com

3 Safety Information

Important Information

Read these instructions carefully and look at the equipment to become familiar with the device before trying to install, operate, service, or maintain it. The following special messages may appear throughout this documentation or on the equipment to warn of potential hazards or to call attention to information that clarifies or simplifies a procedure.



The addition of this symbol to a Danger or Warning safety label indicates that an electrical hazard exists, which will result in personal injury if the instructions are not followed.



This is the safety alert symbol. It is used to alert you to potential personal injury hazards. Obey all safety messages that follow this symbol to avoid possible injury or death.

DANGER

DANGER indicates a hazardous situation which, if not avoided, **will result in** death or serious injury.

WARNING

WARNING indicates a hazardous situation which, if not avoided, **can result in** death or serious injury.

CAUTION

CAUTION indicates a potentially hazardous situation which, if not avoided, **can result in** minor or moderate injury.

NOTICE

NOTICE is used to address practices not related to physical injury.

Please Note

Electrical equipment should be installed, operated, serviced, and maintained only by qualified personnel. No responsibility is assumed by Schneider Electric for any consequences arising out of the use of this material.

A qualified person is one who has skills and knowledge related to the construction, installation, and operation of electrical equipment and has received safety training to recognize and avoid the hazards involved.

Before You Begin

Do not use this product on machinery lacking effective point-of-operation guarding. Lack of effective point-of-operation guarding on a machine can result in serious injury to the operator of that machine.

 WARNING
EQUIPMENT OPERATION HAZARD <ul style="list-style-type: none">• Verify that all installation and set up procedures have been completed.• Before operational tests are performed, remove all blocks or other temporary holding means used for shipment from all component devices.• Remove tools, meters, and debris from equipment. Failure to follow these instructions can result in death or serious injury.

Follow all start-up tests recommended in the equipment documentation. Store all equipment documentation for future reference.

Test all software in both simulated and real environments.

Verify that the completed system is free from all short circuits and grounds, except those grounds installed according to local regulations (according to the National Electrical Code in the U.S.A, for instance). If high-potential voltage testing is necessary, follow recommendations in equipment documentation to help prevent accidental equipment damage.

Operation and Adjustments

The following precautions are from the NEMA Standards Publication ICS 7.1-1995 (English version prevails):

- Regardless of the care exercised in the design and manufacture of equipment or in the selection and ratings of components, there are hazards that can be encountered if such equipment is improperly operated.
- It is sometimes possible to misadjust the equipment and thus produce unsatisfactory or unsafe operation. Always use the manufacturer's instructions as a guide for functional adjustments. Personnel who have access to these adjustments should be familiar with the equipment manufacturer's instructions and the machinery used with the electrical equipment.
- Only those operational adjustments actually required by the operator should be accessible to the operator. Access to other controls should be restricted to help prevent unauthorized changes in operating characteristics.

Acceptable Use

SCADAPack E remote Programmable Automation Controllers (rPACs), Remote Terminal Units (RTUs) and input/output (I/O) modules are intended for use in monitoring and controlling non-critical equipment only. They are not intended for safety-critical applications.

WARNING

UNACCEPTABLE USE

Do not use SCADAPack E rPACs, RTUs, or I/O modules as an integral part of a safety system. These devices are not safety products.

Failure to follow this instruction can result in death or serious injury.

CAUTION

EQUIPMENT OPERATION HAZARD

When devices are used for applications with technical safety requirements, the relevant instructions must be followed.

Use only Schneider Electric software or approved software with Schneider Electric hardware products.

Failure to follow these instructions can result in minor or moderate injury.

4 Overview

The 5611 I/O module is integrated with a SCADAPack 313E or SCADAPack 333E controller and is not available as a standalone unit.

The 5611 I/O module increases the I/O capability of a SCADAPack E Smart RTU by providing 4 analog inputs, 16 digital inputs and 10 relay digital outputs.

A maximum of one (1) 5611 modules (and seven (7) 5606, 5607, 5608, or 5610 modules together) can be addressed on a 5000 Series I/O bus.

The analog inputs are used with devices such as pressure, level, flow, and temperature transmitters; instrumentation such as pH and conductivity sensors; and other high-level analog signal sources. The 5611 input module measures current or voltage inputs in the ranges 0 to 20mA, 4-20mA, 0 to 5 V or 1 to 5 V. Each input is individually configured for input type and range. The 5611 module uses a 16-bit analog to digital (A/D) converter.

The 5611 I/O and outputs are transient protected and optically isolated from the main logic power. The inputs are single ended. They share a common return.

The digital inputs are optically isolated from the logic power. To simplify field wiring, the inputs are grouped with inputs sharing a single common return. These groups of eight inputs are isolated from each other. Light emitting diodes show the status of each of the inputs. The digital inputs are available in two standard voltage ranges, for both AC and DC applications.

The 5611 adds ten, dry contact, Form A (normally open) mechanical relay outputs to a 5000 Series input/output system. The relay outputs can be used to control panel lamps, relays, motor starters, solenoid valves, and other on/off devices. The relay outputs are well suited to applications that cannot tolerate any off-state leakage current, that require high load currents, or that involve non-standard voltages or current ranges.

This manual covers the powering, wiring and configuration of a 5611 I/O module only. It is meant to be used with the hardware manual of the respective controller board to which the I/O module is attached.

5 Installation

The installation of the 5611 module requires mounting the module on the 7.5mm by 35mm DIN rail and connecting the module to the system I/O Bus. Refer to the Schneider Electric **System Configuration Guide** for complete information on system layout, I/O Bus cable routing and module installation.

Field Wiring Connectors

The 5611 I/O modules use screw termination style connectors for termination of field wiring. These connectors accommodate solid or stranded wires from 12 to 22 AWG.

Remove power before servicing unit.

The 5611 I/O Module has eight termination connectors for the connection of field wiring. Refer to [Figure 5.1: 5611 I/O Module Layout](#)^[12] for wiring connector locations.

- Primary power input connections and optional analog output connections are wired to a 5 pole connector labeled P3. Refer to Section [Power Supply Overview and Requirements](#)^[13] for more information on these connections. Loop current will only flow in analog inputs that have been configured for 20mA and when power is applied to P3.
- The four analog inputs are wired to a connector labeled P4. Refer to Section [Analog Inputs](#)^[16] for more information on wiring analog input signals.
- The digital outputs are wired to connectors labeled P6 and P7. Refer to the Section [Digital Inputs & Outputs \(Digital Outputs\)](#)^[25] for details on wiring the digital outputs.
- The digital inputs are wired to connectors labeled P5 and P8. Refer to Section [Digital Inputs & Outputs \(Digital Inputs\)](#)^[25] for details on wiring the digital inputs.

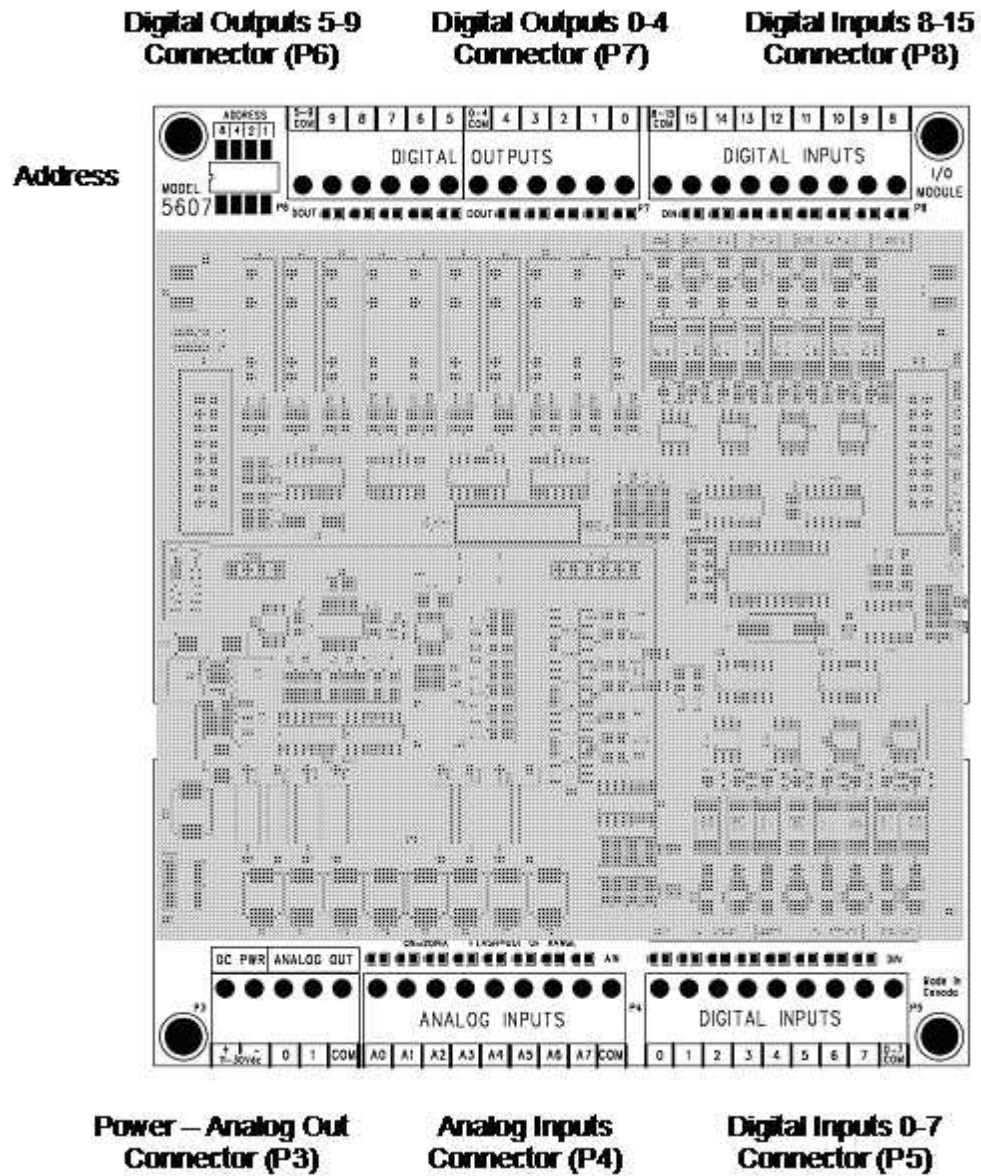

Figure 5.1: 5611 I/O Module Layout

6 Power Supply Overview and Requirements

The 5611 I/O module requires a nominally 12V or 24V DC power supply applied to the terminals labeled 11-30V on connector P3 to power the analog input and optional analog output circuitry.

The current requirement of the analog portion (input and optional output circuitry) on the 5611 I/O board can vary from a minimum of 12mA for basic operation of the analog circuitry plus an additional 40mA for the optional analog outputs.

In addition, the system controller or power supply provides 5V through the I/O Bus cable. Refer to the Specifications section of the controller manual for the power capabilities of the controller. A sample power calculation for integrated SCADAPack controller utilizing this I/O board can be found in the manual of the corresponding controller board.

Power for the I/O board can be provided in several ways:

- A 24Vdc source connected to the DC PWR terminals on the controller board and on the 5611 I/O module in a parallel configuration. See Section [Recommended 24V Power Supply Configuration](#)  for an example on this wiring configuration.
- With a 12Vdc source connected to the DC PWR terminals on the controller board and on the 5611 I/O module in a parallel configuration. Refer to the hardware manual of the controller modules for an example on this wiring configuration.
- A 5103 UPS Power Supply supplies 5Vdc to the controller board through the IMC cable and supplies 24Vdc to the 5611 I/O module through the 24Vdc output. Refer to the hardware manual of the controller modules for an example on this wiring configuration.

System Grounding

It is desirable to ground the system by connecting the system power supply common, to the chassis or panel ground. On the 5611 I/O module, the “-” terminal of the 11-30V supply (DC PWR “-”) along with terminals labeled COM are isolated from the chassis.

6.1 Recommended 24V Power Supply Configuration

This configuration uses a 24V power supply to power the controller board and the 5611 I/O module. This 24V is used to power the analog circuitry for the analog on the 5611 I/O module.

Notes on this configuration:

- This configuration is recommended when a large amount of current is required at 24V. Refer to Section [Specifications](#) [34].
- The Controller Board DC Power terminal needs to be connected to the same power supply as the 5611 I/O Module DC Power terminals.

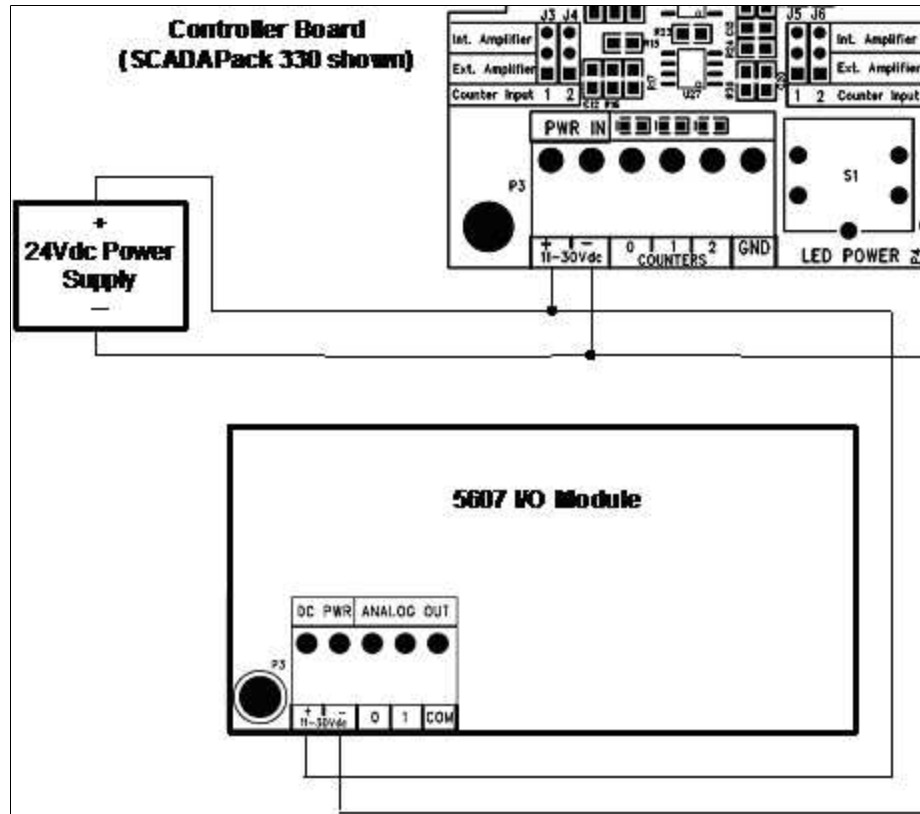

Figure 6.2: Recommended DC Power Supply Configuration

7 DIP Switch Settings

Address Selection

5000 Series I/O module types may be combined in any manner to the maximum supported by the controller used.

Each type of I/O module, connected to the I/O bus, needs to have a unique I/O module address. Different types of I/O modules may have the same module address.

The address range supported by the controller module may restrict the I/O module address range. Refer to the controller manual for the maximum address supported.

5611 Addressing

Three address switches on the 5611 labeled 4, 2, and 1 set the address. A 5611 I/O module that is installed in a SCADAPack is generally set to address 0. Address 0 can be used if there is no 5606, 5607, 5608, 5609, 5610 or 5611 module installed in a SCADAPack. A first additional module is generally set to address 1.

The 5606, 5607, 5608, 5609, 5610 and 5611 modules share the same address numbering, and therefore any of these modules types on the I/O bus need to have unique address numbers.

To set the address:

1. Open the four switches by sliding the actuators to the "OFF" position.
2. Close the switches that total to the desired address by sliding the actuators to "ON". Switch settings for each of the 8 module addresses are shown in the figure below.

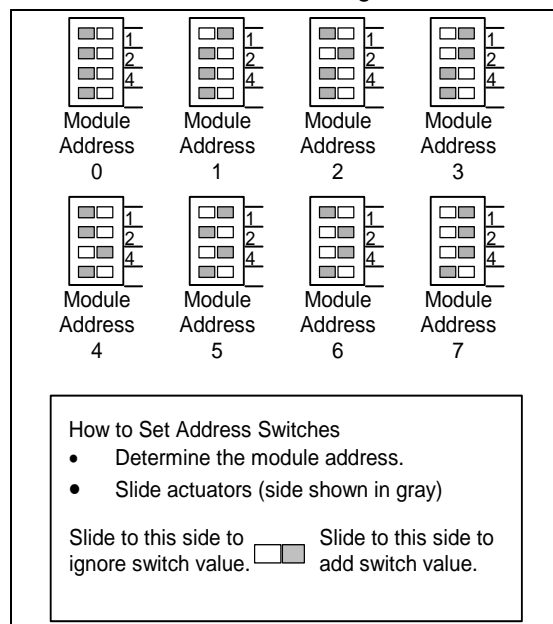

Figure 7.1: 5611 Address Switch Settings

8 Analog Inputs

The 5611 I/O module enhances the capacity of a SCADAPack controller by providing an additional eight single ended analog inputs on connector P4 that can be configured for current or voltage mode. Refer to [Figure 5.1: 5611 I/O Module Layout](#)^[12] for the location of this connector.

Analog inputs can be configured for current or voltage mode via software. Please refer to the Section [Current or Voltage Mode & Range and Resolution \(Current or Voltage Mode\)](#)^[17] below on how to choose input modes.

- In voltage mode, these analog inputs are single ended with a measurement range of 0-5V or 0-10V. The range is selected via software.
- In current mode, a 250 Ω current sense resistor appears across each analog input channel. Measurement range in current mode is 0-20mA or 4-20mA selectable via software. The 250 Ω resistor produces a voltage drop (input reading) of 5V for a 20mA of current flow.

The analog inputs use a 16-bit successive approximation digital to analog (A/D) converter.

- Use SCADAPack E Configurator to assign RTU database points to the I/O card channels
- For ISaGRAF applications use I/O board connections to the RTU point database (rtuxxxx boards) or Complex Equipment types (sp334e) to read the eight analog inputs.

Please refer to the ISaGRAF software and SCADAPack E Configurator manuals on how to assign RTU points to use ISaGRAF I/O Boards and Complex Equipment types.

Configuration for points attached to the 5611 Analog Input channels uses the SCADAPack E RAW_MIN / RAW_MAX and ENG_MIN / ENG_MAX parameters for integer and engineering scaling, respectively. These scaling ranges apply to the analog input signal range selected by SCADAPack E Configurator for each analog input point channel on the 5611 I/O module.

8.1 Current or Voltage Mode & Range and Resolution

Current or Voltage Mode

The analog inputs on the 5611 module can be configured for either voltage or current mode via SCADAPack E Configurator.

In current mode a 250Ω resistor appears across the analog input channel. In voltage mode, input channels are high impedance.

Range and Resolution

The 5611 analog inputs (Channels 0-3) have a 16-bit, unipolar, analog to digital (A/D) converter that measures input voltages from 0-5V or 0-10V. The analog inputs are factory calibrated to scale the data and represent it with a 16 bit signed number.

When assigning RTU database points to the 5611 module channels using SCADAPack E Configurator, the user configures the **Input Type** signal range for each analog input channel.

The following **Input Type** ranges can be configured for each 5611 analog input channel:

- 0 to 5V
- 1 to 5V
- 0 to 10V
- 0 to 20mA
- 4 to 20mA

The **Input Type** range selected is scaled to the **Raw Min.** to **Raw Max.** range configured for the individual analog input point when point integer values are used. The **Eng. Min.** to **Eng. Max.** range for the point is used to scale the analog input Engineering Floating Point database value.

For example, if a SCADAPack 334E analog input or 5611 Module point's attributes are RAW_MIN = 0, RAW_MAX = 10000 and the input channel is selected for 4-20mA: a 20mA input is 100% of the selected input signal range and corresponds to 10000 counts. a 4mA input is 0% of the selected input signal range and corresponds to 0 counts.

The following table shows the analog input values and status for several input signals. Over and under range status detection occurs when the measured input is outside of the measurement range by greater than 0.2%.

Table 8.1: Analog Input Signals

0-5V Range (V)	1-5V Range (V)	0-10V Range (V)	4-20mA Range (mA)	0-20mA Range (mA)	Point database value	Over or under range status*
N/A	< 0.992	N/A	<3.968	N/A	under-range	ON
0V	1	0V	4	0	RAW_MIN ENG_MIN	OFF

0-5V Range (V)	1-5V Range (V)	0-10V Range (V)	4-20mA Range (mA)	0-20mA Range (mA)	Point database value	Over or under range status*
1.25	2	2.5	8	5	25% of scale	OFF
2.5	3	5.0	12	10	50% of scale	OFF
3.75	4	7.5	16	15	75% of scale	OFF
5	5	10	20	20	RAW_MAX ENG_MAX	OFF
5.0024	5.0024	10.0048	20.032	20.01	over-range	ON

* Under-range and Over-range point status may also be asserted by SCADAPack E Analog Input Point configuration parameters. For more information see the *SCADAPack E 5000 Series I/O Expansion Reference* manual and *SCADAPack E Data Processing Technical Reference* manual.

8.2 Wiring

The analog inputs support loop powered and self powered transmitters. Loop powered transmitters are two terminal devices that connect between a power supply and the analog input. The loop current continues from the power supply, through the transmitter and to ground through a 250Ω resistor built into the 20mA input circuit. Self-powered transmitters have three terminals called power in, signal out and common. Self-powered transmitters can have a current or voltage output. The signal out connects to the Analog Input Channel, the common connects to COM and the power in connects to a power supply.

Wiring Example

[Figure 8.1: Analog Input Wiring](#) ²⁰¹ below shows several examples for wiring of transmitters loop and self powered transmitters with the corresponding analog inputs set to voltage mode with a 0-5V measurement range.

<i>NOTICE</i>
UNEXPECTED EQUIPMENT OPERATION
Do not exceed the maximum voltage specified for each analog input.
Failure to follow these instructions can result in equipment damage.

 WARNING
HAZARD OF ELECTRIC SHOCK
Remove power from all devices before connecting or disconnecting inputs or outputs to any terminal or installing or removing any hardware.
Failure to follow these instructions can result in death or serious injury.

This module should be the only loop current measurement device in the loop when using the analog inputs in the 20mA measurement mode. If power to the module is removed, the module reverts to voltage mode and in-effect opens the current loop. Applications that cannot tolerate this possibility need to utilize external current sense resistors, and with the module input range set to voltage.
--

- Example 1: Channel 0 has a loop powered current transmitter connected to the external power supply.
- Example 2: Channel 1 has a self-powered voltage transmitter connected to the external power supply. Channels 2 through 6 are unused.
- Example 3: Channel 3 has a self-powered current transmitter connected to the external power supply.

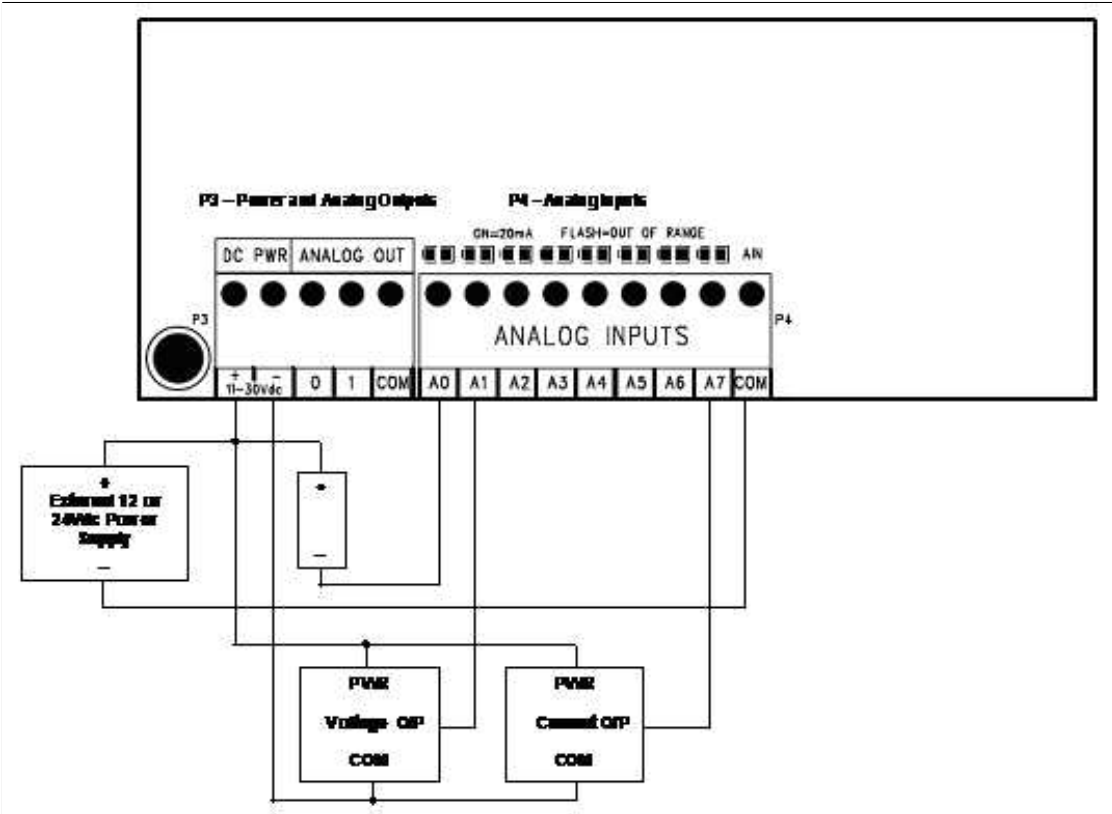

Figure 8.1: Analog Input Wiring

9 Analog Outputs

The 5611 I/O Module may include two channels of analog output if this option was requested at time of purchase.

- Use SCADAPack E Configurator to assign RTU database points to the I/O card channels
- For ISaGRAF applications use I/O board connections to the RTU point database (rtuxxxx boards) or Complex Equipment types (sp334e) to write the two analog outputs.

Please refer to the ISaGRAF software and SCADAPack E Configurator manuals on how to assign RTU points to use ISaGRAF I/O Boards and Complex Equipment types.

- [Current & Voltage Outputs](#)²²
- [Range and Resolution](#)²³

9.1 Current & Voltage Outputs

Current Outputs

The 5611 I/O Module can be equipped with an optional 5305 Analog Output Module that provides two 20mA analog outputs. Analog output resolution is 12 bits. The outputs are transient and over voltage protected. The outputs share a common return (GND) with each other and the 5611 I/O Module analog inputs. The figure below gives an illustration on how to connect current outputs.

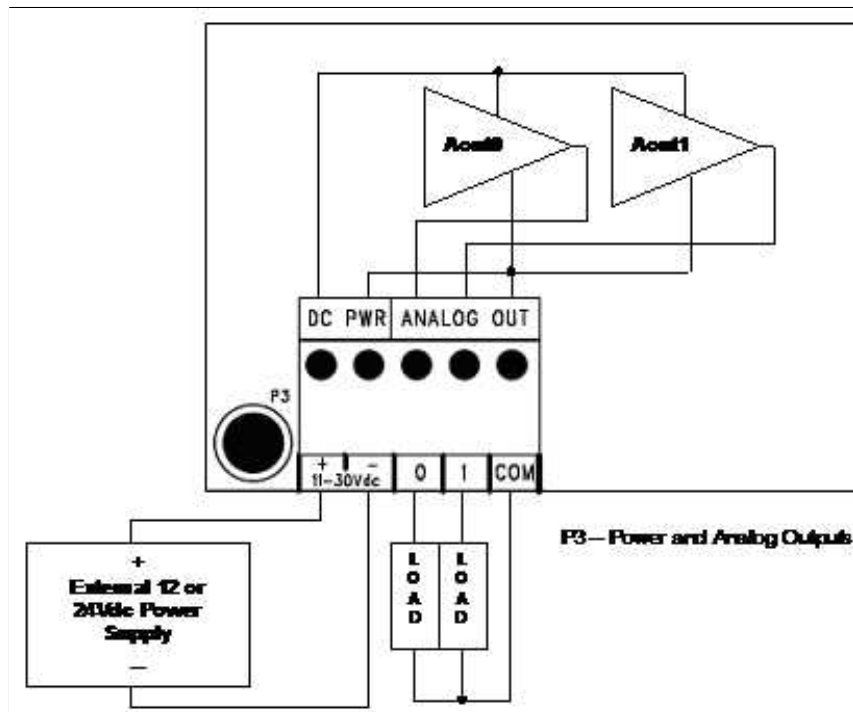

Figure 9.1: Analog Output Wiring

Voltage Outputs

To obtain voltage outputs, connect a load resistor as shown in [Figure 9.1: Analog Output Wiring](#) ²² above and connect the voltage device across the load resistor. The table below lists resistance values and output range settings for common voltage ranges. The resistance value listed is the parallel resistance of the device and the load resistor.

Table 9.1: Resistance Values and Output Ranges

Resistance	Output Range	Voltage Range
250Ω	0-20mA	0 to 5V
	4-20mA	1 to 5V
500Ω	0-20mA	0 to 10V

9.2 Range and Resolution

The optional analog output module installed on the 5611 I/O Module has a 12-bit, unipolar, digital to analog (D/A) converter. One of the following **Output Type** ranges can be configured on SCADAPack E Configurator **I/O | SCADAPack I/O** page for the 5611 module. Both AO channels use the same range:

- 0 to 20mA
- 4 to 20mA

The 0-20mA output range resolution is 4.88 μ A per D/A count.

Configuration for points attached to the optional 5611 Analog Output channels uses the SCADAPack E Raw Min. to Raw Max. and Eng. Min. to Eng. Max. parameters for integer and engineering scaling, respectively.

These scaling ranges automatically apply to the analog input signal range selected by SCADAPack E Configurator for the 5611 module analog **Output Type** (0-20mA or 4-20mA).

10 Digital I/O Overview

The 5611 I/O provides 16 digital input and 10 dry digital (mechanical relay) outputs.

- Use SCADAPack E Configurator to assign RTU database points to the I/O card channels
- For ISaGRAF applications use I/O board connections to the RTU point database (rtuxxx boards) or Complex Equipment types (sp334e) to read the digital inputs or control the relay outputs.

Please refer to the ISaGRAF software and SCADAPack E Configurator manuals on how to assign RTU points to use ISaGRAF I/O Boards and Complex Equipment types.

- [Digital Inputs & Outputs](#)²⁵
- [Wiring Examples](#)²⁶

10.1 Digital Inputs & Outputs

Digital Inputs

The digital inputs are optically isolated from the logic power and are available in four standard voltage ranges, for both AC and DC applications. A current limiting resistor, on each input, determines the voltage range. Light Emitting Diodes (LED) on the digital inputs show the status of each of the input. The digital input LEDs can be disabled to conserve power.

To simplify field wiring, the 16 inputs are organized into two groups of eight inputs. Each group shares a common return. These groups of eight inputs are isolated from each other. Inputs 0 to 7 are in one group. Inputs 8 to 15 are in another group.

Digital Outputs

NOTICE

UNEXPECTED EQUIPMENT OPERATION

Incandescent lamps and other loads may have inrush currents that will exceed the rated maximum current of the relay contacts. This inrush current may damage the relay contacts. Interposing relays need to be used in these situations.

Failure to follow these instructions can result in equipment damage.

The 5611 I/O module has 10 dry contact, digital (mechanical relay) outputs. Outputs are Form A (normally open NO). Loads can be connected to either output terminal and to either the high or the low side of the power source. Light Emitting Diodes (LEDs) on the digital outputs show the status of each of the outputs. The digital output LEDs can be disabled to conserve power.

10.2 Wiring Examples

The 5611 I/O module accommodates AC or DC inputs.

The voltage range is configured at the factory.

NOTICE

UNEXPECTED EQUIPMENT OPERATION

Do not exceed the maximum voltage specified for each digital input.

Failure to follow these instructions can result in equipment damage.

NOTICE

UNEXPECTED EQUIPMENT OPERATION

Incandescent lamps and other loads may have inrush currents that will exceed the rated maximum current of the relay contacts. This inrush current may damage the relay contacts. Interposing relays need to be used in these situations.

Failure to follow these instructions can result in equipment damage.

NOTICE

UNEXPECTED EQUIPMENT OPERATION

When controlling inductive loads, the relay contacts on digital outputs must be protected. The energy stored in the coil can generate significant electrical noise when the relay contacts are opened.

To suppress the noise in DC circuits, place a diode across the coil.

To suppress the noise in AC circuits, place a metal-oxide varistor (MOV) across the coil.

Failure to follow these instructions can result in equipment damage.

WARNING

HAZARD OF ELECTRIC SHOCK

Remove power from all devices before connecting or disconnecting inputs or outputs to any terminal or installing or removing any hardware.

Failure to follow these instructions can result in death or serious injury.

[Figure 10.1: Digital Input Wiring of DC Signals](#)²⁷¹ shows typical wiring of DC signals to the digital input ports.

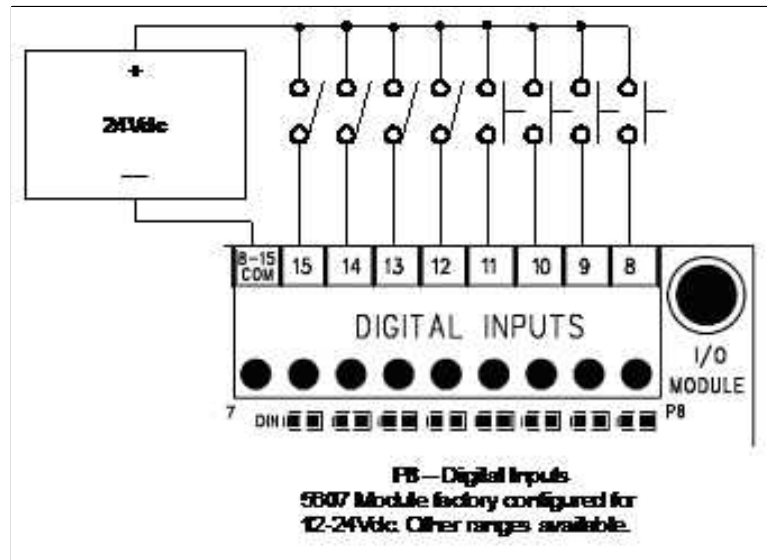

Figure 10.1: Digital Input Wiring of DC Signals

[Figure 10.2: Digital Input Wiring of AC Signals](#)²⁷¹ shows a typical wiring of AC signals to the digital input ports.

Signal polarity needs to be observed when using DC inputs. Connect the positive signal to the input. Connect the negative signal to the common.

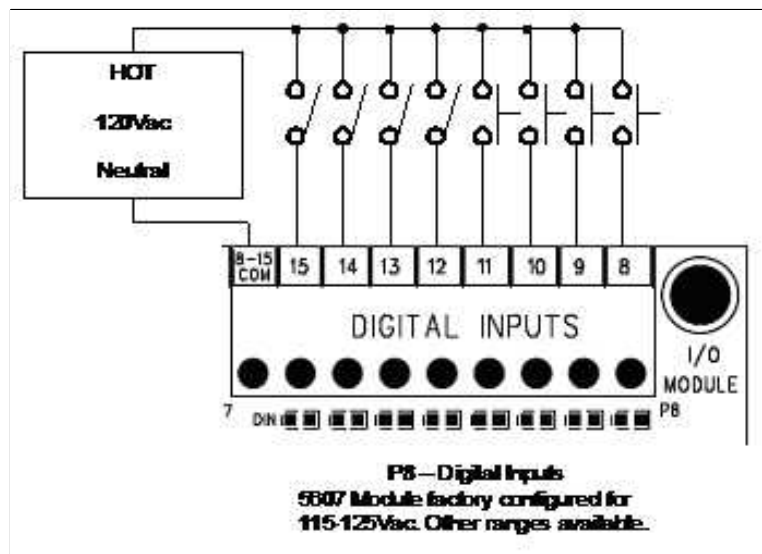

Figure 10.2: Digital Input Wiring of AC Signals

11 Operation and Maintenance

LED Indicators

There are 56 LED's on the 5611 I/O Module. LED's can be disabled by the controller board to conserve power. Refer to the manual of your controller board for details on disabling the LEDs.

The table below describes the LED's.

Table 11.1: LED Indicators

LED	Function
DOUTs	On when the corresponding output is on.
DINs	On when the corresponding input is on.
AINs	On when analog input is configured for current. Off when analog input is configured for voltage. Long flashes when the applied current is out of range. Short flashes when the applied voltage is out of range.*

* Under-range is not indicated on analog input channel LEDs on the 5611 I/O module when configured in 1-5V input range.

Maintenance

This module requires no routine maintenance. If the module is not functioning correctly, contact Schneider Electric Technical Support for more information and instructions for returning the module for repair.

11.1 Troubleshooting

Calibration

The 5611 module is calibrated at the factory. It does not require periodic calibration. Calibration may be necessary if the module has been repaired as a result of damage. Calibration is done electronically at the factory. There are no user calibration procedures.

- [Analog Inputs & Outputs](#)  321
- [Digital Inputs & Outputs](#)  331

11.1.1 Analog Inputs & Outputs

Analog Inputs

Condition	Action
20mA inputs read 0.	Check transmitter power.
Reading is at or near 0 for every input signals.	Check if the input transient suppressers are damaged.
20mA readings are not accurate.	Check for a damaged 250Ω current sense resistor.
Reading is constant.	Check that the analog input is not forced.
Reading seems out of calibration for small inputs but improves as input increases.	Check the input range setting.

Analog Outputs

Condition	Action
Outputs are 0mA	Check the 24V power.
The full-scale output is less than 20mA.	Check the 24V power. Check that the load resistance is within specification.
Output is constant and should be changing.	Check that the analog outputs are not forced.

11.1.2 Digital Inputs & Outputs

Digital Inputs

Condition	Action
Input LED does not come on when input signal is applied.	Check the input signal at the termination block. It should be at least 50% of the digital input range. If this is a DC input, check the polarity of the signal.
Input is on when no signal is applied. The LED is off.	Check that the digital inputs are not forced on.
Input is off when a signal is applied. The LED is on.	Check that the digital inputs are not forced off.

Digital Outputs

Condition	Action
Output LED does not come on when output is turned on.	Check the LED POWER from the SCADAPack controller.
Output LED comes on but the output does not close.	Check if the relay is stuck. If so, return the board for repair.
Output LED comes on and output is closed, but the field device is not activated.	Check the field wiring. Check the external device.
Output LED and relay are on when they should be off.	Check that the output is not forced on.
Output LED and relay are off when they should be on.	Check that the output is not forced off.

12 Specifications

Disclaimer: Schneider Electric reserves the right to change product specifications without notice. For more information visit <http://www.schneider-electric.com>.

- [General & Power Supply](#)³⁵
- [Analog Inputs](#)³⁶
- [Analog Outputs](#)³⁷
- [Digital Inputs](#)³⁸
- [Relay Digital Outputs](#)³⁹

12.1 General & Power Supply

General

I/O Terminations	12 to 22 AWG 15A contacts Screw termination - 6 lb.-in. (0.68 Nm) torque
Dimensions	5.65 inch (144mm) wide 6.50 inch (165mm) high 1.80 inch (72mm) deep
Packaging	corrosion resistant zinc plated steel with black enamel paint
Environment	5% RH to 95% RH, non-condensing -25°C to 70°C (-13°F to 158°F) operation -40°C to 85°C (-40°F to 185°F) storage
Addressing	8 modules. DIP switch selectable.

Power Supply

5V power requirements (Dry Contact Relay Version)	Digital Output Relays Continuous - 195mA LEDs - 107mA Quiescent - 23mA Total - up to 325mA
5V power requirements (Solid State Relay Version)	Digital Output Relays Continuous - 100mA LEDs - 110mA Quiescent - 23mA Total - up to 233mA
11-30Vdc power requirements	12mA plus analog outputs 9-30Vdc operation possible when optional 5305 analog outputs not installed UL508 rated 13.75 to 28Vdc.
11-30Vdc - Connector	Removable. 5 positions.
11-30Vdc - Isolation	Isolation from logic supply and chassis

12.2 Analog Inputs

Quantity	4
Ranges	Software configurable 0-20mA 4-20mA 0-10V 0-5V 1-5V
Input resistance	250 ohms - Current configuration. 20k ohms - Voltage configuration.
Resolution	15 bits over the 0-10V and 0-20mA measurement range
Type	single ended
Accuracy	±0.1% of full scale at 25°C (77°F) ±0.2% over temperature range
Transient Protection	2.5kV surge withstand capability as per ANSI/IEEE C37.90.1-1989
Normal mode rejection at 60Hz with 60Hz scanning	30dB with 3Hz filter 28dB with 6Hz filter 23dB with 11Hz filter 21dB with 30Hz filter
Normal mode rejection at 50Hz with 50Hz scanning	51dB with 3Hz filter 49dB with 6Hz filter 38dB with 11Hz filter 21dB with 30Hz filter
Response Time for 10% to 90% signal	300mS with 3Hz filter 140mS with 6Hz filter 60mS with 11Hz filter 20mS with 30Hz filter
Over-scale Input Capacity (without damage)	Continuous: 0.10A/14V on the 20mA inputs. 0.05A/14V on the 5V inputs.
Connector	Removable. 9 positions.
Isolation	Isolation from logic supply and chassis. 500VAC
Indicators	Logic powered LEDs. Can be disabled to conserve power. Indicate Voltage / Current mode and out-of-range input signal

12.3 Analog Outputs

Quantity	2 with optional 5305 module
Range	0-20mA sourcing 4-20mA sourcing
Resolution	12 bits
Maximum Load Resistance	925 Ω with 24Vdc input voltage or when internal 24V power supply is on. 375 Ω with 12Vdc input voltage 250 Ω with input voltage at power supply turnoff
Accuracy	Accuracy specified from 0.5-20mA. $\pm 0.15\%$ of full scale at 25°C (77°F) $\pm 0.25\%$ of full scale over temperature range
Noise and Ripple	0.04% maximum
Transient Protection	2.5kV surge withstand capability as per ANSI/IEEE C37.90.1-1989
Logic End-Of- Scan to Signal Update Latency	With up to 10 off 5000 Series I/O Modules: Typical: 18-27mS
Response time (D/A to signal)	less than 10 μ s for 10% to 90% signal change
Connector	Removable. 5 positions.
Isolation	Isolation from logic supply and chassis

12.4 Digital Inputs

Quantity	16	
Ranges	Factory configurable 12/24V 48V 115/125V 240V	
Over-voltage Tolerance	150% sustained over-voltage without damage	
Input Current	0.67 mA typical at 24V on the 12/24V range 0.37 mA typical at 48V on the 48V range 0.35 mA typical at 120V on the 115/125V range 0.35 mA typical at 240V on the 240V range	
Input Logic-HI Level	OFF to ON transition threshold is typically 6.5V on 12/24V range OFF to ON transition threshold is typically 50% of full scale range on other ranges.	
AC Input Voltage 12V/24V 48V 115/125V 240V	Off – To – On 7.5Vrms+/- 2Vrms 25Vrms +/- 5Vrms 65Vrms+/- 5Vrms 135Vrms+/-10Vrms	On – To – Off 6.0Vrms+/- 2Vrms 20Vrms +/- 5Vrms 55Vrms+/- 5Vrms 115Vrms+/-10Vrms
DC Input Voltage 12V/24V 48V 115/125V 240V	Off – To – On 6.5Vdc+/- 0.5Vdc 22Vdc+/-5Vdc 65Vdc+/-5Vdc 125Vdc+/-10Vdc	On – To – Off 6.5Vdc+/- 0.5Vdc 22Vdc+/-5Vdc 65Vdc+/-5Vdc 125Vdc+/-10Vdc
AC Response Time @50 Hz @60 Hz	Off – To – On 5 – 22ms 5— 22ms	On – To – Off 6 – 18ms 6 – 18ms
DC Response Time @50 Hz @60 Hz	Off – To – On 15 – 19ms 13.5 – 18ms	On – To – Off 25 – 29ms 23 - 28ms
Connectors	2 removable. 9 positions.	
Isolation	Isolation is in 2 groups of 8. Isolation from logic supply and chassis: 250Vac/1000Vdc.	
Indicators	Logic powered LEDs. Can be disabled to conserve power.	

12.5 Digital Outputs

Quantity	10
Connectors	2 removable. 6 positions.
Type	Form A Contacts (Normally open) 5 contacts share one common
Indicators	Logic powered LEDs. Can be disabled to conserve power.
Voltages	Maximum permitted voltage in Canada or North America is 240Vac. Maximum permitted voltage outside of Canada or North America is 30Vac/42.4Vpk/60Vdc.
Inductive Loads	Inductive loads need to be suitably protected to protect the relay contacts. See the Wiring Examples ^[26] topic for the recommended inductive load protection circuits.
Isolation	Chassis to contact: 1500Vac (1 min.) Logic to contact: 1500Vac (1 min.) Isolation is in 2 groups of 5 Output group to output group: 1500Vac (1 min.)
Operate Time	25ms maximum, 20ms typical
Release Time	30ms maximum, 25ms typical
Dry Contact Relay Version	
Contact rating	3A, 30Vdc or 240Vac (Resistive) 1000Vac between open contacts 12A maximum per common
Switching Capacity	5A, 30Vdc (150W Resistive) 5A X 250Vac (1250VA Resistive)
Service Life	2 X 10 ⁷ mechanical 1 X 10 ⁵ at contact rating
Bounce Time	1ms typical

DC Solid State Relay Version	
Load Voltage	60Vdc maximum
Load Current	3A continuous maximum at 50°C ambient 2A continuous maximum at 70°C ambient 9A peak, 100mS UL508 rated 2A at 50°C and 1.33A at 70°C
On Resistance	0.09 ohms
Off State Leakage Current	10µA
Service Life	Unlimited
Bounce Time	None

13 Approvals and Certifications

Safety	UL (cULus) listed: UL508 (Industrial Control Equipment), CSA C22.2 No.142-M1987 (Process Control Equipment)
Digital Emissions	FCC47 Part 15, Subpart B, Class A Verification EN61000-6-4: 2007 Electromagnetic Compatibility Generic Emission Standard Part2: Industrial Environment C-Tick compliance. Registration number N15744
Immunity	EN61000-6-2: 2005 Electromagnetic Compatibility Generic Standards Immunity for Industrial Environments
CE Mark Declaration	This product conforms to the above Emissions and Immunity Standards and therefore conforms with the requirements of Council Directive 2004/108/EEC (as amended) relating to electromagnetic compatibility and is eligible to bear the CE mark The Low Voltage Directive is not applicable to this product

Schneider Electric

415 Legget Drive, Suite 101, Kanata, Ontario K2K 3R1 Canada

Direct Worldwide: +1 (613) 591-1943

Fax: +1 (613) 591-1022

Toll Free within North America: 1 (888) 267-2232

www.schneider-electric.com

Copyright © 2014 - 2017 Schneider Electric Canada Inc. All Rights Reserved.