

### CAUTION:

If any questions arise concerning the proper installation or maintenance of our products, please contact Protectoseal or one of our Authorized Representatives.

When installing any Protectoseal device, the legal, corporate and advisory safety regulations and procedures appropriate for the specific installation site must be fully understood and followed.



**NOTE 1:** When pressure loading weights are included with a unit they may be shipped separately to avoid damage to the unit. The weight(s) should be inspected, properly identified and set aside for later installation.

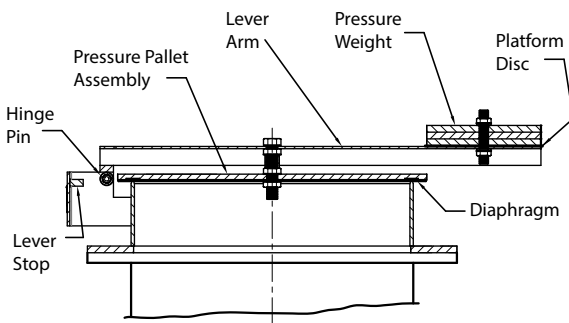

4. If a setting weight is provided it is to be mounted on the lever arm assembly of the vent. Locate mounting hole on end of lever arm. Position platform disc on lever arm aligning holes. Install weight(s) on platform. Insert supplied stud and assemble with washers & nuts. Tighten fastener securely, using a recommended torque value of 50 ft. lb. (+/- 5 ft. lb.).
5. When tank pressure exceeds the vent set pressure, the pallet assembly will hinge open as required to flow vapors and relieve the pressure. When the pressure is reduced, the pallet assembly will automatically return to its closed position.

### INSTALLATION PROCEDURE:

1. Remove and discard all protective packaging material from on or inside the vent. Remove and discard cardboard and tape from the pallet assembly. This cardboard protects the diaphragm during shipment.
2. Check carefully to insure that no packing or protective materials remain on or inside the vent base or the pallet assembly.
3. Mount the vent to the appropriate tank flange using gaskets compatible with service conditions. For best performance, the vent should be mounted level so that the seating surfaces are no more than 1° off horizontal. Make sure that the pallet assembly is free to hinge open and to reclose.

## MAINTENANCE:

Protectoseal recommends that our products be inspected and maintained according to the normal maintenance schedule of the facility. At a minimum, maintenance should be conducted annually. More frequent maintenance may be required, and should be scheduled, for unusual service conditions.

**CAUTION: When maintaining any Protectoseal device, the legal, corporate and advisory safety regulations and procedures appropriate for the specific installation site must be fully understood and followed.**

**CAUTION: Tank vapor space pressure or vacuum should be relieved before any maintenance operations are undertaken.**

## MAINTENANCE PROCEDURE:

1. Open the pallet assembly fully by lifting lever arm. Pallet will rotate open about hinge center. NOTE: Depending on the set point of the vent, the weight of the pallet, lever arm and weight combination may be significant - exercise caution.

2. Remove any loose dirt or foreign material from the seating surface and from the pallet assembly.
3. Inspect and clean the machined seating surface of the base with a suitable cleaning fluid. The seat should be free of nicks, marks or accumulations of foreign material.

**CAUTION: Do not use a file or other sharp tool to clean the seating surface**

4. Inspect the pallet assembly. If the pallet is deteriorated or bent, it must be replaced. Inspect the diaphragm material in the pallet assembly. The diaphragm must be clean, flat and smooth. If the diaphragm material is deteriorated, it must be replaced. The diaphragm can be replaced by loosening the fastener that secures the diaphragm and retaining washer. Remove the washer to expose the diaphragm. Install a new diaphragm, reposition the retaining washer and secure the retaining nut.
5. Remove any temporary bracing and slowly lower the pallet assembly to its closed position.

Distributed by:



888.858.3647 | relevantsolutions.com

## ADDITIONAL PRODUCTS FROM PROTECTOSEAL

Series 53300



Emergency Pressure Manhole Cover Vents provide emergency pressure relief for storage tanks where vacuum relief is being provided for by a separate operating vent

Series 7800



Emergency Vent protects tanks against rupture or explosion resulting from excessive internal pressure caused by exposure to fires.

Series 4950



Vent Line / In-Line Parallel Plate Flame Arrester is designed for installation in open vent pipe or bleed lines from storage or processing tanks. Suitable for NEC Group D (IEC Group IIA) vapors

Series 830



Combination Pressure / Vacuum Relief Vent & Flame Arrester provides pressure and vacuum relief as well as protection from propagation of externally introduced flames. Suitable for NEC Group D (IEC Group IIA) vapors.