

# SERIES 51700

## Hinged Emergency Pressure Manhole Cover Vent

# SERIES 51700

- Vents directly to atmosphere
- Sizes 16" (DN 400) through 24" (DN 600)
- Pressure setting achieved by weight loading
- Hinged/counterweight design allows for higher settings
- Cover design allows for easy access to tank
- Patented, FEP film "Air-Cushioned Seating"
- Conforms to the latest ATEX Directive
- Low-leak pallet design - certified test reports
- Easy access manway facilitates inspection & repairs
- Available in Carbon Steel, Aluminum & Stainless Steel



### OBJECTIVE

Protectoseal Series 51700 Hinged Emergency Pressure Manhole Cover Vent provides emergency pressure relief for storage tanks that are exposed to an external fire. They are designed for installation on the manhole openings of tanks and provide a means of relieving large volumes of vapor, beyond the capacity of a normal operating vent. The Series 51700 design allows for higher pressure relief settings than are available on our Series 53300 Emergency Pressure Manhole Cover Vent. Series 51700 Manhole Cover Vents do not provide vacuum relief. Vacuum relief must be supplied by the operating vent with which the tank is equipped. See Protectoseal Series 830, 8540, 6240, 16240 and 18540. Series 52500 Manway Cover Vents include pressure and vacuum relief.

### TECHNIQUE

When positioned on the flanged seat, the Series 51700 Hinged Emergency Pressure Manhole Cover Vent provides an effective vapor-tight seal. Under emergency fire conditions, the cover can pivot open on its hinge and provide required relief, preventing damage to the tank due to excessive internal pressure. When tank pressure is reduced, the cover automatically recloses. The hinged design allows the use of a lever principle counterweight so that pressure settings higher than those available on our Series 53300 Emergency Pressure Manhole Cover Vent may be achieved. The design allows convenient access through the manhole opening for tank inspection and maintenance.

### SPECIAL FEATURES

**Fast Inspection, Easy Maintenance.** Design and light weight of unit permit easy, convenient handling for inspection and maintenance. Opening of hinged cover allows access into tank through the seat area.

**Higher Pressure Settings.** The hinged design and lever arm loading capabilities of the Series 51700 allows for higher pressure settings than are available on other dead weight loaded vents of similar size. Full open flow capacity and automatic reclosing of the vent as tank pressure decreases provide

efficient and dependable emergency venting capability while minimizing amount of vapor unnecessarily vented to the atmosphere.

**Maintains Accurate Pressure Settings.** Set points are accurate to within +/- 3% across the entire range of available pressure relief settings shown in the chart on the reverse. Set point accuracy is assured by stringent machining, assembly and test procedures.

**Air-Cushioned Seating.** A flat, smooth diaphragm of FEP film is supported on both sides of an annular channel to form a floating air seal with the seat. An outer support rim assures proper seating.

**Low-Leak Covers.** Leakage on vent covers is no more than 1 SCFH at 90% of the set pressure. For above standard settings leakage rate will be higher, consult factory.

**Sizes Available.** Available in 16" (DN 400) through 24" (DN 600) sizes. Flanged to mate with standard flanged 125# ANSI, API (20" or 24" only) or DIN PN 16 bolting specifications. Other drilling patterns are also available upon special request.

### PRO-FLOW Sizing and Selection Software.

Use PRO-FLOW® to select the correct size unit for emergency pressure relief calculated in accordance with API 2000, ISO 28300, NFPA 30 and OSHA 1910.106.

### CONSTRUCTION

A comprehensive range of materials is offered as shown in the chart below.

#### Available Options.

- Alternate diaphragm materials
- Material certifications for flange and seat
- FEP coating
- Kynar® coating (*Kynar® is a Registered Trademark of Arkema, Inc.*)

Series	Base Flange/Seat	Cover / Pallet	Diaphragm	Lever Arm*
AX51700	Steel/316 S.S.	Aluminum	FEP Film	Steel
AXCS51700	Steel/316 S.S.	Steel	FEP Film	Steel
AXF51700	316 S.S.	316 S.S.	FEP Film	316 S.S.

\* On specific models.

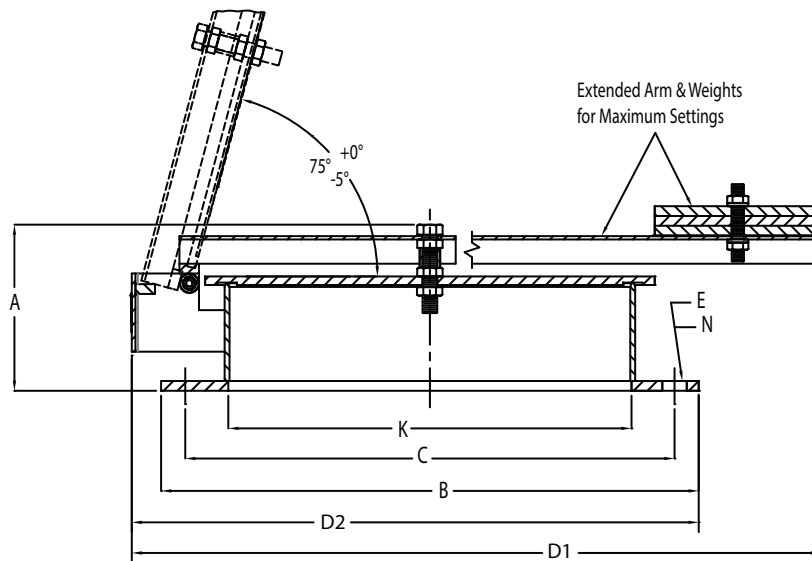

Dimensions shown are for reference only. contact factory for certified drawings.

### DIMENSIONS & ORDERING INFORMATION

Cat. No.	Flange Size	I.D. K	Ht. A	Overall Length		Dia. B	B.C. C	Dia. E	Holes N
				D1	D2				
51716ASA	16"	15 <sup>1</sup> / <sub>4</sub> "	8 <sup>1</sup> / <sub>2</sub> "	29 <sup>3</sup> / <sub>4</sub> "	24 <sup>1</sup> / <sub>4</sub> "	23 <sup>1</sup> / <sub>2</sub> "	21 <sup>1</sup> / <sub>4</sub> "	1 <sup>1</sup> / <sub>8</sub> "	16
51716DN	DN 400	410mm	216mm	756mm	608mm	580mm	525mm	30mm	16
51718ASA	18"	15 <sup>1</sup> / <sub>4</sub> "	8 <sup>1</sup> / <sub>2</sub> "	29 <sup>3</sup> / <sub>4</sub> "	25"	25"	22 <sup>3</sup> / <sub>4</sub> "	1 <sup>1</sup> / <sub>4</sub> "	16
51718DN	DN 450	462mm	216mm	756mm	640mm	635mm	578mm	30mm	16
51720ASA	20"	20 <sup>1</sup> / <sub>2</sub> "	8 <sup>1</sup> / <sub>2</sub> "	35 <sup>1</sup> / <sub>4</sub> "	29"	27 <sup>1</sup> / <sub>2</sub> "	25"	1 <sup>1</sup> / <sub>4</sub> "	20
51720API	20"	20 <sup>1</sup> / <sub>2</sub> "	8 <sup>1</sup> / <sub>2</sub> "	35 <sup>1</sup> / <sub>4</sub> "	28 <sup>1</sup> / <sub>4</sub> "	26"	23 <sup>1</sup> / <sub>2</sub> "	3/4"	16
51720DN	DN 500	513mm	216mm	895mm	745mm	715mm	650mm	33mm	20
51724ASA	24"	24"	8 <sup>1</sup> / <sub>2</sub> "	39"	33 <sup>1</sup> / <sub>16</sub> "	32"	29 <sup>1</sup> / <sub>2</sub> "	1 <sup>3</sup> / <sub>8</sub> "	20
51724API	24"	24"	8 <sup>1</sup> / <sub>2</sub> "	39"	32 <sup>1</sup> / <sub>16</sub> "	30"	27 <sup>1</sup> / <sub>2</sub> "	3/4"	20
51724DN	DN 600	616mm	216mm	991mm	853mm	840mm	770mm	36mm	20

Add Prefix	Base Flange/Seat	Cover / Pallet	Diaphragm	Lever Arm (on specific models)
AX	Steel/316 S.S.	Aluminum	FEP Film	Steel
AXCS	Steel/316 S.S.	Steel	FEP Film	Steel
AXF	316 S.S.	316 S.S.	FEP Film	316 S.S.

### MINIMUM / MAXIMUM PRESSURE SETTINGS (Consult factory for settings outside of ranges shown below.)

Series	Flange Size	No Lever Arm Models						Lever Arm Model			
		51700 / L*		51700 / C		51700					
		Minimum*		Std. Minimum		Std. Maximum		Std. Minimum		Std. Maximum	
		oz./in. <sup>2</sup>	in. W.C.	oz./in. <sup>2</sup>	in. W.C.	oz./in. <sup>2</sup>	in. W.C.	oz./in. <sup>2</sup>	in. W.C.	oz./in. <sup>2</sup>	in. W.C.
AX51716	16"/DN 400	0.73	1.26	1.25	2.16	< 2.17	< 3.75	2.17	3.75	20.0	34.6
AXCS & AXF51716	16"/DN 400	0.79	1.37	2.80	4.84	< 3.74	< 6.47	3.74	6.47	20.0	34.6
AX51718	18"/DN 450	0.73	1.26	1.25	2.16	< 2.17	< 3.75	2.17	3.75	20.0	34.6
AXCS & AXF51718	18"/DN 450	0.79	1.37	2.80	4.84	< 3.74	< 6.47	3.74	6.47	20.0	34.6
AX51720	20"/DN 500	0.61	1.06	1.14	1.97	< 1.73	< 2.99	1.73	2.99	16.0	27.7
AXCS & AXF51720	20"/DN 500	0.69	1.19	2.67	4.62	< 3.28	< 5.67	3.28	5.67	16.0	27.7
AX51724	24"/DN 600	0.57	0.99	1.11	1.92	< 1.57	< 2.72	1.57	2.72	16.0	27.7
AXCS & AXF51724	24"/DN 600	0.75	1.30	2.73	4.72	< 3.13	< 5.41	3.13	5.41	16.0	27.7

\* Modified Design - Consult Factory.



225 Foster Ave., Bensenville, IL 60106-1690  
 P 630.595.0800 F 630.595.8059  
 info@protectoseal.com www.protectoseal.com